

# Asymptotically rigid mapping class groups and Thompson's groups

*Louis Funar, Christophe Kapoudjian and Vlad Sergiescu*

*Institut Fourier BP 74, UMR 5582  
University of Grenoble I  
38402 Saint-Martin-d'Hères cedex, France  
e-mail: {funar,sergiesc}@fourier.ujf-grenoble.fr*

*Laboratoire Emile Picard, UMR 5580  
University of Toulouse III  
31062 Toulouse cedex 4, France  
e-mail: ckapoudj@picard.ups-tlse.fr*

**Abstract.** We consider Thompson's groups from the perspective of mapping class groups of surfaces of infinite type. This point of view leads us to the braided Thompson groups, which are extensions of Thompson's groups by infinite (spherical) braid groups. We will outline the main features of these groups and some applications to the quantization of Teichmüller spaces. The chapter provides an introduction to the subject with an emphasis on some of the authors results.

2000 MSC Classification: 57 M 07, 20 F 36, 20 F 38, 57 N 05.

Keywords: mapping class group, Thompson group, Ptolemy groupoid, infinite braid group, quantization, Teichmüller space, braided Thompson group, Euler class, discrete Godbillon-Vey class, Hatcher-Thurston complex, combable group, finitely presented group, central extension, Grothendieck-Teichmüller group.

## Contents

1	Introduction . . . . .	2
2	From Thompson's groups to mapping class groups of surfaces . . . . .	5
2.1	Three equivalent definitions of the Thompson groups . . . . .	5
2.2	Some properties of Thompson's groups . . . . .	10
2.3	Thompson's group $T$ as a mapping class group of a surface . . . . .	11
2.4	Braid groups and Thompson groups . . . . .	14
2.5	Extending the Burau representation . . . . .	16
3	From the Ptolemy groupoid to the Hatcher-Thurston complex . . . . .	17
3.1	Universal Teichmüller theory according to Penner . . . . .	17

3.2	The isomorphism between Ptolemy and Thompson groups . . . . .	20
3.3	A remarkable link between the Ptolemy groupoid and the Hatcher-Thurston complex of $\mathcal{S}_{0,\infty}$ , following [50] . . . . .	25
3.4	The Hatcher-Thurston complex of $\mathcal{S}_{0,\infty}$ . . . . .	27
4	The universal mapping class group in genus zero . . . . .	29
4.1	Definition of the group $\mathcal{B}$ . . . . .	29
4.2	$\mathcal{B}$ is finitely presented . . . . .	30
5	The braided Ptolemy-Thompson group . . . . .	31
5.1	Finite presentation . . . . .	31
5.2	Asynchronous combability . . . . .	33
6	Central extensions of $T$ and quantization . . . . .	36
6.1	Quantum universal Teichmüller space . . . . .	36
6.2	The dilogarithmic representation of $T$ . . . . .	40
6.3	The relative abelianization of the braided Ptolemy-Thompson group $T^*$ . . . . .	45
6.4	Computing the class of $T_{\text{ab}}^*$ . . . . .	48
6.5	Identifying the two central extensions of $T$ . . . . .	49
6.6	Classification of central extensions of the group $T$ . . . . .	50
7	More asymptotically rigid mapping class groups . . . . .	51
7.1	Other planar surfaces and braided Houghton groups . . . . .	51
7.2	Infinite genus surfaces and mapping class groups . . . . .	56
8	Cosimplicial extensions for the Thompson group $V$ . . . . .	59
8.1	Strand doubling maps . . . . .	59
8.2	Cosimplicial $\mathfrak{S}$ -extensions . . . . .	60
8.3	Dyadic trees and the functor $\mathbf{K}$ . . . . .	61
8.4	Extensions of Thompson's group $V$ . . . . .	63
8.5	Main examples . . . . .	64
8.6	The universal mapping class group in genus zero and the Grothendieck-Teichmüller group . . . . .	67
9	Problems . . . . .	69

## 1 Introduction

The purpose of this chapter is to present the recently developed interaction between mapping class groups of surfaces, including braid groups, and Richard J. Thompson's groups  $F, T$  and  $V$ . We follow here the present authors' geometrical approach, while giving some hints to the algebraic developments of Brin and Dehornoy and the quasi-conformal approach of de Faria, Gardiner and Harvey.

When compared to mapping-class groups, already thoroughly studied by Dehn and Nielsen, Thompson's groups appear quite recent. Introduced by Richard J. Thompson in the middle of the 1960s, they originally developed from algebraic logic; however, a PL representation of them was immediately obtained.

Recall that Thompson's group  $F$  is the group of PL homeomorphisms of  $[0, 1]$  which locally are of the form  $2^n + \frac{p}{2^q}$ , with breaks in  $\mathbb{Z}[\frac{1}{2}]$ . The group  $T$  acts in a similar way on the unit circle  $S^1$ . The group  $V$  acts by left continuous bijections on  $[0, 1]$  as a group of affine interval exchanges. This action may be lifted to a continuous one on the triadic Cantor set.

By conjugating these groups via the Farey map sending the rationals to the dyadics, one obtains a similar definition as groups of piecewise  $\mathrm{PSL}(2, \mathbb{Z})$  maps with rational breakpoints; this definition already has a certain 2-dimensional flavour. Observe that Thompson's groups act near the boundary of the hyperbolic disk and thus near the boundary of the infinite binary tree. This observation played a basic role in the beginning of the material discussed here. From this point of view Thompson's group  $T$  is a piecewise generalisation of  $\mathrm{SL}(2, \mathbb{Z})$ ; the mapping class group is a multi-handle generalisation of  $\mathrm{SL}(2, \mathbb{Z})$ . In the same vein  $\mathrm{SL}(n, \mathbb{Z})$  is an arithmetic generalization and  $\mathrm{Aut}(F_n)$  is a non-commutative one. We also note that, following Thurston, the mapping class group  $\Gamma_g$  acts on the boundary of the Teichmüller space and preserves its piecewise projective integral structure.

Another way to encode these groups is to consider pairs of binary trees which represent dyadic subdivisions. Dually, this data gives a simplicial bijection of the complementary forests, called partial automorphism of the infinite binary tree  $\tau_2$ . Of course this does not extend as an automorphism of  $\tau_2$ . However, one observes the following simple but essential fact: if one thickens the infinite tree  $\tau_2$  to a surface  $\mathcal{S}_{0, \infty}$ , then the corresponding partial homeomorphisms extend to the entire surface  $\mathcal{S}_{0, \infty}$ . Thus, two objects appear here: the surface  $\mathcal{S}_{0, \infty}$  and the mapping class group which lifts the elements of a Thompson group.

To make definitions precise, we are forced to endow the surface  $\mathcal{S}_{0, \infty}$  with a rigid structure which encodes its tree-like aspect. The homeomorphisms we consider are asymptotically rigid, i.e. they preserve the rigid structure outside a compact sub-surface. These homeomorphisms give rise to the asymptotically rigid mapping class groups.

We now give some details on the structure of this chapter. We present in Section 1 various constructions of groups and spaces and explain how the group  $T$  itself is a mapping class group of  $\mathcal{S}_{0, \infty}$ . Next, we introduce the (historically) first relation between Thompson groups and braid groups, namely the extension:

$$1 \rightarrow B_\infty \rightarrow A_T \rightarrow T \rightarrow 1$$

In order to avoid working with non-finitely supported braids, the authors chose to build  $A_T$  from a convenient geometric homomorphism

$$T \rightarrow \mathrm{Out}(B_\infty)$$

However, retrospectively, while having definite advantages, this choice may not have been the best. The main theorem of [68] says that the group  $A_T$  is almost acyclic – the corresponding group  $A_{F'}$  being acyclic. The proofs of these theorems are quite involved and far from the geometric-combinatorial topics discussed in the rest of this chapter; this is why we shall present them rather sketchily. However, we do describe the group  $A_T$  as a mapping class group. It is actually while trying to extend the Burau representation from  $B_\infty$  to  $A_T$  that the notion of asymptotically rigid mapping class group was formulated.

The next two sections, 2 and 3, are of central importance. We show that a group  $\mathcal{B}$  which is an asymptotically rigid mapping class group of  $\mathcal{S}_{0,\infty}$  and surjects onto  $V$  is finitely presented. While the acyclicity theorem mentioned above was formulated on the basis of homotopy-theoretic evidence, the group  $\mathcal{B}$  and its finite presentability came largely from conformal field theory evidence. The Moore-Seiberg duality groupoid is finitely presented, a fact mathematically established in [4, 5, 49].

We begin by introducing Penner's Ptolemy groupoid, partly issued from the conformal field theory work of Friedan and Shenker. Its objects are ideal tessellations and its morphisms are compositions of flips. We then explain how Thompson's groups fit into this setting. A basic observation here is that the Ptolemy groupoid is isomorphic to a sub-groupoid of the Moore-Seiberg stable duality groupoid. This duality groupoid is related in turn to a Hatcher-Thurston type complex for the surface  $\mathcal{S}_{0,\infty}$ . One main result is that this complex is simply connected.

Section 3 applies all this to the asymptotically rigid mapping class group  $\mathcal{B}$  of  $\mathcal{S}_{0,\infty}$ .

Let us emphasize here that our notion of asymptotically rigid mapping class group is different from the asymptotic mapping class group considered recently by various authors (see the chapter written by Matsuzaki in volume IV of this handbook).

The kernel of the morphism from  $\mathcal{B}$  onto  $V$  is the compactly supported mapping class group of  $\mathcal{S}_{0,\infty}$ . Let us note that the group  $\mathcal{B}$  contains all genus zero mapping class groups as well as the braid groups. The main theorem states that  $\mathcal{B}$  is a finitely presented group. A quite compact symmetric set of relations is produced as well.

Section 4 is dedicated to the braided Ptolemy-Thompson group  $T^*$ . This is an extension of  $T$  by the braid group  $B_\infty$ . It is an asymptotically rigid mapping class group of  $\mathcal{S}_{0,\infty}$  of a special kind. It is a simpler group than  $A_T$  and will be used in Sections 5 and 6. We prove that  $T^*$ , like  $\mathcal{B}$ , is a finitely presented group. We note that so far,  $A_T$  is only known to be finitely generated.

In Section 5, we consider a relative abelianisation of  $T^*$ :

$$1 \rightarrow \mathbb{Z} = B_\infty/[B_\infty, B_\infty] \rightarrow T^*/[B_\infty, B_\infty] \rightarrow T \rightarrow 1$$

We prove that this central extension is classified by a multiple of the Euler class of  $T$  that we detect to be  $12\chi$ , where  $\chi$  is the Euler class pulled-back to  $T$ . This fact eventually allows us to classify the dilogarithmic projective extension of  $T$  which arises in the quantization of the Teichmüller theory, as we explain as well.

In Section 6 we discuss an infinite genus mapping class group that maps onto  $V$  which is proved to be (at least) finitely generated. It also has the property of being homologically equivalent to the stable mapping class group. As already mentioned, the proofs involve as a key ingredient the group  $T^*$ .

In Section 7 we introduce a simplicial unified approach to the various extensions of the group  $V$ . This includes the extension  $BV$  of Matt Brin and Patrick Dehornoy coming from categories with multiplication and from the geometry of algebraic laws, respectively. Moreover, one can approach in this way the action of the Grothendieck-Teichmüller group on a  $V$ -completion  $\widehat{\mathcal{B}}$  of  $\mathcal{B}$ , thus getting a quite neat presentation of the entire setting.

A sample of open questions is contained in the final section.

We would like to dedicate these notes to the memory of Peter Greenberg and of Alexander Reznikov. Their work is inspiring us forever.

**Acknowledgments.** The authors are indebted to L. Bartholdi, M. Bridson, M. Brin, J. Burillo, D. Calegari, F. Cohen, P. Dehornoy, D. Epstein, V. Fock, R. Geogheghan, E. Ghys, S. Goncharov, F. González-Acuña, V. Guba, P. Haissinsky, B. Harvey, V. Jones, R. Kashaev, F. Labourie, P. Lochak, J. Morava, H. Moriyoshi, P. Pansu, A. Papadopolous, B. Penner, C. Pittet, M. Sapir, L. Schneps and H. Short for useful discussions and suggestions concerning this subject during the last few years.

## 2 From Thompson's groups to mapping class groups of surfaces

### 2.1 Three equivalent definitions of the Thompson groups

**Groups of piecewise affine bijections** *Thompson's group*  $F$  is the group of continuous and nondecreasing bijections of the interval  $[0, 1]$  which are piecewise dyadic affine. In other words, for each  $f \in F$ , there exist two subdivisions of  $[0, 1]$ ,  $a_0 = 0 < a_1 < \dots < a_n = 1$  and  $b_0 = 0 < b_1 < \dots < b_n$ , with  $n \in \mathbb{N}^*$ , such that :

- (1)  $a_{i+1} - a_i$  and  $b_{i+1} - b_i$  belong to  $\{\frac{1}{2^k}, k \in \mathbb{N}\}$ ;

- (2) the restriction of  $f$  to  $[a_i, a_{i+1}]$  is the unique nondecreasing affine map onto  $[b_i, b_{i+1}]$ .

Therefore, an element of  $F$  is completely determined by the data of two dyadic subdivisions of  $[0, 1]$  having the same cardinality.

Let us identify the circle to the quotient space  $[0, 1]/0 \sim 1$ . *Thompson's group*  $T$  is the group of continuous and nondecreasing bijections of the circle which are piecewise dyadic affine. In other words, for each  $g \in T$ , there exist two subdivisions of  $[0, 1]$ ,  $a_0 = 0 < a_1 < \dots < a_n = 1$  and  $b_0 = 0 < b_1 < \dots < b_n$ , with  $n \in \mathbb{N}^*$ , such that :

- (1)  $a_{i+1} - a_i$  and  $b_{i+1} - b_i$  belong to  $\{\frac{1}{2^k}, k \in \mathbb{N}\}$ .
- (2) There exists  $i_0 \in \{1, \dots, n\}$ , such that, pour each  $i \in \{0, \dots, n-1\}$ , the restriction of  $g$  to  $[a_i, a_{i+1}]$  is the unique nondecreasing map onto  $[b_{i+i_0}, b_{i+i_0+1}]$ . The indices must be understood modulo  $n$ .

Therefore, an element of  $T$  is completely determined by the data of two dyadic subdivisions of  $[0, 1]$  having the same cardinality, say  $n \in \mathbb{N}^*$ , plus an integer  $i_0 \bmod n$ .

Finally, *Thompson's group*  $V$  is the group of bijections of  $[0, 1[$ , which are right-continuous at each point, piecewise nondecreasing and dyadic affine. In other words, for each  $h \in V$ , there exist two subdivisions of  $[0, 1]$ ,  $a_0 = 0 < a_1 < \dots < a_n = 1$  and  $b_0 = 0 < b_1 < \dots < b_n$ , with  $n \in \mathbb{N}^*$ , such that :

- (1)  $a_{i+1} - a_i$  and  $b_{i+1} - b_i$  belong to  $\{\frac{1}{2^k}, k \in \mathbb{N}\}$ ;
- (2) there exists a permutation  $\sigma \in \mathfrak{S}_n$ , such that, for each  $i \in \{1, \dots, n\}$ , the restriction of  $h$  to  $[a_{i-1}, a_i[$  is the unique nondecreasing affine map onto  $[b_{\sigma(i)-1}, b_{\sigma(i)}[$ .

It follows that an element  $h$  of  $V$  is completely determined by the data of two dyadic subdivisions of  $[0, 1]$  having the same cardinality, say  $n \in \mathbb{N}^*$ , plus a permutation  $\sigma \in \mathfrak{S}_n$ . Denoting  $I_i = [a_{i-1}, a_i]$  and  $J_i = [b_{i-1}, b_i]$ , these data can be summarized into a triple  $((J_i)_{1 \leq i \leq n}, (I_i)_{1 \leq i \leq n}, \sigma \in \mathfrak{S}_n)$ .

Such a triple is not uniquely determined by the element  $h$ . Indeed, a refinement of the subdivisions gives rise to a new triple defining the same  $h$ . This remark also applies to elements of  $F$  and  $T$ .

The inclusion  $F \subset T$  is obvious. The identification of the integer  $i_0 \bmod n$  to the cyclic permutation  $\sigma : k \mapsto k + i_0$  yields the inclusion  $T \subset V$ .

R. Thompson proved that  $F, T$  and  $V$  are finitely presented groups and that  $T$  and  $V$  are simple (cf. [26]). The group  $F$  is not perfect ( $F/[F, F]$  is isomorphic to  $\mathbb{Z}^2$ ), but  $F' = [F, F]$  is simple. However,  $F'$  is not finitely generated (this is related to the fact that an element  $f$  of  $F$  lies in  $F'$  if and only if its support is included in  $]0, 1[$ ).

Historically, Thompson's groups  $T$  and  $V$  are the first examples of infinite simple and finitely presented groups. Unlike  $F$ , they are not torsion-free.

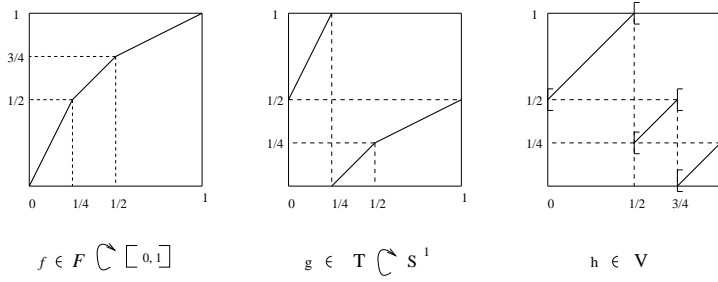

Figure 1. Piecewise dyadic affine bijections representing elements of Thompson's groups

**Groups of diagrams of finite binary trees** A *finite binary rooted planar tree* is a finite planar tree having a unique 2-valent vertex, called the *root*, a set of monovalent vertices called the *leaves*, and whose other vertices are 3-valent. The planarity of the tree provides a canonical labelling of its leaves, in the following way. Assuming that the plane is oriented, the leaves are labelled from 1 to  $n$ , from left to right, the root being at the top and the leaves at the bottom.

There exists a bijection between the set of dyadic subdivisions of  $[0, 1]$  and the set of finite binary rooted planar trees. Indeed, given such a tree, one may label its vertices by dyadic intervals in the following way. First, the root is labelled by  $[0, 1]$ . Suppose that a vertex is labelled by  $I = [\frac{k}{2^n}, \frac{k+1}{2^n}]$ , then its two descendant vertices are labelled by the two halves  $I$ :  $[\frac{k}{2^n}, \frac{2k+1}{2^{n+1}}]$  for the left one and  $[\frac{2k+1}{2^{n+1}}, \frac{k+1}{2^n}]$  for the right one. Finally, the dyadic subdivision associated to the tree is the sequence of intervals which label its leaves.

As we have just seen, an element of Thompson's group  $V$  is defined by the data of two dyadic subdivisions of  $[0, 1]$ , with the same cardinality  $n$ , plus a permutation  $\sigma \in \mathfrak{S}_n$ . This amounts to encoding it by a pair of finite binary rooted trees with the same number of leaves  $n \in \mathbb{N}^*$ , plus a permutation  $\sigma \in \mathfrak{S}_n$ .

Thus, an element  $h$  of  $V$  is represented by a triple  $(\tau_1, \tau_0, \sigma)$ , where  $\tau_0$  and  $\tau_1$  have the same number of leaves  $n \in \mathbb{N}^*$ , and  $\sigma$  belongs to the symmetric group  $\mathfrak{S}_n$ . Such a triple will be called a *symbol* for  $h$ . It is convenient to interpret the permutation  $\sigma$  as the bijection  $\varphi_\sigma$  which maps the  $i$ -th leaf of the source tree  $\tau_0$  to the  $\sigma(i)$ -th leaf of the target tree  $\tau_1$ . When  $h$  belongs to  $F$ , the permutation  $\sigma$ , which is the identity, is not represented, and the symbol reduces to a pair of trees  $(\tau_1, \tau_0)$ . When  $h$  belongs to  $T$ , the cyclic permutation is graphically materialized by a small circle surrounding the leaf number  $\sigma(1)$  of  $\tau_1$ .

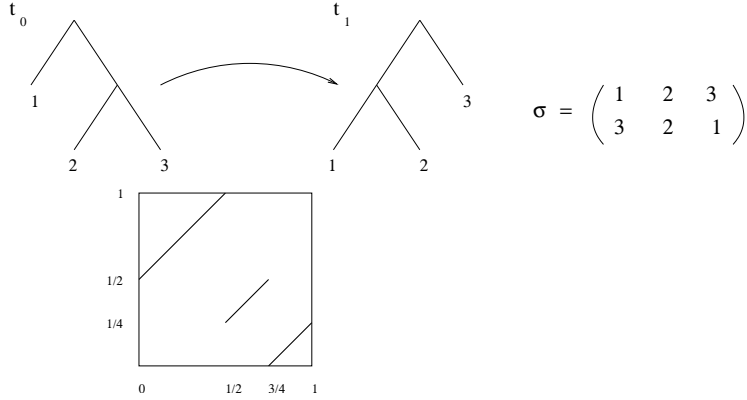

Figure 2. Symbolic representation of an element of  $V$ , with its corresponding representation as a piecewise dyadic affine bijection

One introduces the following equivalence relation on the set of symbols : two symbols are equivalent if they represent the same element of  $V$ . One denotes by  $[\tau_1, \tau_0, \sigma]$  the equivalence class of the symbol. Therefore,  $V$  is (in bijection with) the set of equivalence classes of symbols. The composition law of piecewise dyadic affine bijections is pushed out on the set of equivalence classes of symbols in the following way. In order to define  $[\tau'_1, \tau'_0, \sigma'] \cdot [\tau_1, \tau_0, \sigma]$ , one may suppose, at the price of refining both symbols, that the tree  $\tau_1$  coincides with the tree  $\tau'_0$ . The the product of the two symbols is

$$[\tau'_1, \tau_1, \sigma'] \cdot [\tau_1, \tau_0, \sigma] = [\tau'_1, \tau_0, \sigma' \circ \sigma].$$

The neutral element is represented by any symbol  $(\tau, \tau, 1)$ , for any finite binary rooted planar tree  $\tau$ . The inverse of  $[\tau_1, \tau_0, \sigma]$  is  $[\tau_0, \tau_1, \sigma^{-1}]$ .

It follows that  $V$  is isomorphic to the group of equivalence classes of symbols endowed with this internal law.

**Partial automorphisms of trees ([84])** The beginning of the article [84] formalizes a change of point of view, consisting in considering, not the finite binary trees, but their complements in the infinite binary tree.

Let  $\mathcal{T}_2$  be the infinite binary rooted planar tree (all its vertices other than the root are 3-valent). Each finite binary rooted planar tree  $\tau$  can be embedded in a unique way into  $\mathcal{T}_2$ , assuming that the embedding maps the root of  $\tau$  onto the root of  $\mathcal{T}_2$ , and respects the orientation. Therefore,  $\tau$  may be identified with a subtree  $\mathcal{T}_2$ , whose root coincides with that of  $\mathcal{T}_2$ .

**Definition 2.1** ( cf. [84]). A *partial isomorphism* of  $\mathcal{T}_2$  consists of the data of two finite binary rooted subtrees  $\tau_0$  and  $\tau_1$  of  $\mathcal{T}_2$  having the same number of leaves  $n \in \mathbb{N}^*$ , and an isomorphism  $q : \mathcal{T}_2 \setminus \tau_0 \rightarrow \mathcal{T}_2 \setminus \tau_1$ . The complements of  $\tau_0$  and  $\tau_1$  have  $n$  components, each one isomorphic to  $\mathcal{T}_2$ , which are enumerated from 1 to  $n$  according to the labelling of the leaves of the trees  $\tau_0$  and  $\tau_1$ . Thus,  $\mathcal{T}_2 \setminus \tau_0 = T_0^1 \cup \dots \cup T_0^n$  and  $\mathcal{T}_2 \setminus \tau_1 = T_1^1 \cup \dots \cup T_1^n$  where the  $T_j^i$ 's are the connected components. Equivalently, the partial isomorphism of  $\mathcal{T}_2$  is given by a permutation  $\sigma \in \mathfrak{S}_n$  and, for  $i = 1, \dots, n$ , an isomorphism  $q_i : T_0^i \rightarrow T_1^{\sigma(i)}$ .

Two partial automorphisms  $q$  and  $r$  can be composed if and only if the target of  $r$  coincides with the source of  $q$ . One gets the partial automorphism  $q \circ r$ . The composition provides a structure of inverse monoid on the set of partial automorphisms, which is denoted  $\text{Fred}(\mathcal{T}_2)$ .

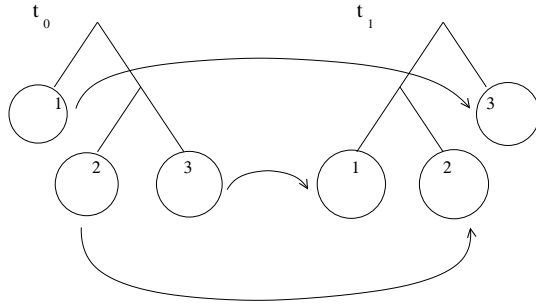

One may construct a group from  $\text{Fred}(\mathcal{T}_2)$ . Let  $\partial\mathcal{T}_2$  be the boundary of  $\mathcal{T}_2$  (also called the set of “ends” of  $\mathcal{T}_2$ ) endowed with its usual topology, for which it is a Cantor set.

The point is that a partial automorphism does not act (globally) on the tree, but does act on its boundary. One has therefore a morphism  $\text{Fred}(\mathcal{T}_2) \rightarrow \text{Homeo}(\partial\mathcal{T}_2)$ , whose image  $N$  is the *spheromorphism group of Neretin*.

Let now  $\text{Fred}^+(\mathcal{T}_2)$  be the sub-monoid of  $\text{Fred}(\mathcal{T}_2)$ , whose elements are the partial automorphisms which respect the local orientation of the edges. Thompson’s group  $V$  can be viewed as the subgroup of  $N$  which is the image of  $\text{Fred}^+(\mathcal{T}_2)$  by the above morphism.

*Remark 2.1.* There exists a Neretin group  $N_p$  for each integer  $p \geq 2$ , as introduced in [103] (with different notation). They are constructed in a similar way as  $N$ , by replacing the dyadic complete (rooted or unrooted) tree by the  $p$ -adic complete (rooted or unrooted) tree. They are proposed as combinatorial or  $p$ -adic analogues of the diffeomorphism group of the circle. Some aspects of this analogy have been studied in [80].

## 2.2 Some properties of Thompson's groups

Most readers of this section are probably more comfortable with the mapping class group than with Thompson's groups. Therefore, we think that it will be useful to gather here some of the classical and less classical properties of Thompson's groups. There is a fair amount of randomness in our choices and the only thing we would really like to emphasize is their ubiquity. Thompson's groups became known in algebra because  $T$  and  $V$  were the first infinite finitely presented simple groups. They were preceded by Higman's example of an infinite finitely generated simple group in 1951. More recently, Burger and Mozes (see [22]) constructed an example which is also without torsion.

Thompson used  $F$  and  $V$  to give new examples of groups with an unsolvable word problem and also in his algebraic characterisation of groups with a solvable word problem (see [115]) as being those which embed in a finitely generated simple subgroup of a finitely presented group. The group  $F$  was rediscovered in homotopy theory, as a universal conjugacy idempotent, and later in universal algebra. We refer to [26] for an introduction from scratch to several aspects of Thompson's groups, including their presentations, and also their piecewise linear and projective representations. One can find as well an introduction to the amenability problem for  $F$ , including a proof of the Brin-Squier-Thompson theorem that  $F$  does not contain a free group of rank 2. Last but not least, one can find a list of the merely 25 notations in the literature for  $F$ ,  $T$  and  $V$ . Fortunately, after [26] appeared, the notation has almost stabilized.

We also mention the survey [114] for various other aspects and [62] and [102] for the general topic of homeomorphisms of the circle.

The groups  $F$ ,  $T$  and  $V$  are actually  $\text{FP}_\infty$ , i.e. they have classifying spaces with finite skeleton in each dimension; this was first proved by Brown and Geoghegan (see [17, 18]). Let us mention what is the rational cohomology of these groups, computed by Ghys and Sergiescu in [63] and Brown in [19]. First,  $H^*(F; \mathbb{Q})$  is the product between the divided powers algebra on one generator of degree 2 and the cohomology algebra of the 2-torus.

The cohomology of  $T$  is the quotient  $\mathbb{Q}(\chi, \alpha)/\chi \cdot \alpha$ , where  $\chi$  is the Euler class and  $\alpha$  a (discrete) Godbillon-Vey class. In what concerns the group  $V$  its rational cohomology vanishes in each dimension. See [114] for more results with either  $\mathbb{Z}$  or with twisted coefficients.

Here are other properties of these groups involving cohomology. Using a smoothening of Thompson's group it is proved in [63] that there is a representation  $\pi_1(\Sigma_{12}) \rightarrow \text{Diff}(S^1)$  having Euler number 1 and an invariant Cantor set.

Reznikov showed that the group  $T$  does not have Kazhdan's property  $T$  (see [111]), and later Farley [39] proved that it has Haagerup property  $\text{AT}$  (also

called a-T-menability). Therefore it verifies the Baum-Connes conjecture (see also [38]). Napier and Ramachandran proved that  $F$  is not a Kähler group [105]. Cyclic cocycles on  $T$  were introduced in [107]. The group  $T$  in relation with the symplectic automorphisms of  $\mathbb{C}\mathbb{P}^2$  was considered by Usnich in [118].

A theorem of Brin [15] states that the group of outer automorphisms of  $T$  is  $\mathbb{Z}/2\mathbb{Z}$ . Furthermore, in [21] the authors computed the abstract commensurator of  $F$ . Using the above mentioned smoothening, it is proved in [63] that all rotation numbers of elements in  $T$  are rational. New direct proofs were given by Calegari ([25]), Lioussé ([90]) and Kleptsyn (unpublished).

For the connection of  $F$  and  $T$  with the piecewise projective  $C^1$ -homeomorphisms, see for instance [66, 67] and [97]. The group  $F$  is naturally connected to associativity in various frameworks [33, 57, 41]. See also [13, 14] for the group  $V$ .

Brin proved that the rank 2 free group is a limit of Thompson's group  $F$  ([16]). Complexity aspects were considered in [9]. Guba ([72]) showed that the Dehn function for  $F$  is quadratic. The group  $F$  was studied in cryptography in [112, 99, 6]. Thompson's groups were studied from the viewpoint of  $\mathbb{C}^*$ -algebras and von Neumann algebras; see for instance Jolissaint ([79]) and Haagerup-Picioroaga [74].

On the edge of logic and group theory, the interpretation of arithmetic in Thompson's groups was investigated by Bardakov-Tolstykh ([6]) and Altinel-Muranov ([2]). Let us finally mention the work of Guba and Sapir on Thompson's groups as diagram groups; see for instance [73].

Let us emphasize here that we avoided to speak on generalisations of Thompson's groups: this topic is pretty large and we think it would not be at its place here. Let us close this section by mentioning again that our choice was just to mention some developments related to Thompson's groups from the unique angle of ubiquity.

### 2.3 Thompson's group $T$ as a mapping class group of a surface

The article [84] is partly devoted to developing the notion of an asymptotically rigid homeomorphism.

**Definition 2.2** (following [84]). (1) Let  $\mathcal{S}_{0,\infty}$  be the oriented surface of genus zero, which is the following inductive limit of compact oriented genus zero surfaces with boundary  $\mathcal{S}_n$ : Starting with a cylinder  $\mathcal{S}_1$ , one gets  $\mathcal{S}_{n+1}$  from  $\mathcal{S}_n$  by gluing a pair of pants (i.e. a three-holed sphere) along each boundary circle of  $\mathcal{S}_n$ . This construction yields, for each  $n \geq 1$ , an embedding  $\mathcal{S}_n \hookrightarrow \mathcal{S}_{n+1}$ , with an orientation on  $\mathcal{S}_{n+1}$  compatible with that of  $\mathcal{S}_n$ . The resulting inductive limit (in the topo-

logical category) of the  $\mathcal{S}_n$ 's is the surface  $\mathcal{S}_{0,\infty}$ :

$$\mathcal{S}_{0,\infty} = \varinjlim \mathcal{S}_n$$

- (2) By the above construction, the surface  $\mathcal{S}_{0,\infty}$  is the union of a cylinder and of countably many pairs of pants. This topological decomposition of  $\mathcal{S}_{0,\infty}$  will be called the *canonical pair of pants decomposition*.

The set of isotopy classes of orientation-preserving homeomorphisms of  $\mathcal{S}_{0,\infty}$  is an uncountable group. The group operation is map composition. By restricting to a certain type of homeomorphisms (called asymptotically rigid), we shall obtain countable subgroups. We first need to complete the canonical decomposition to a richer structure.

Let us choose an involutive homeomorphism  $j$  of  $\mathcal{S}_{0,\infty}$  which reverses the orientation, stabilizes each pair of pants of its canonical decomposition, and has fixed points along lines which decompose the pairs of pants into hexagons. The surface  $\mathcal{S}_{0,\infty}$  can be disconnected along those lines into two planar surfaces with boundary, one of which is called the *visible side* of  $\mathcal{S}_{0,\infty}$ , while the other is the *hidden side* of  $\mathcal{S}_{0,\infty}$ . The involution  $j$  maps the visible side of  $\mathcal{S}_{0,\infty}$  onto the hidden side, and vice versa.

From now on, we assume that such an involution  $j$  is chosen, hence a decomposition of the surface into a “visible” and a “hidden” side.

**Definition 2.3.** The data consisting of the canonical pants decomposition of  $\mathcal{S}_{0,\infty}$  together with the above decomposition into a visible and a hidden side is called the *canonical rigid structure* of  $\mathcal{S}_{0,\infty}$ .

The tree  $\mathcal{T}_2$  may be embedded into the visible side of  $\mathcal{S}_{0,\infty}$ , as the dual tree to the pants decomposition. This set of data is represented in Figure 3.

The surface  $\mathcal{S}_{0,\infty}$  appears already in [50], endowed with a pants decomposition (with no cylinder), dual to the regular unrooted dyadic tree.

In [84], the notion of *asymptotically rigid homeomorphism* is defined. It plays a key role in [50], [51] and [52].

Let us introduce some more terminology. Any connected and compact subsurface of  $\mathcal{S}_{0,\infty}$  which is the union of the cylinder and finitely many pairs of pants of the canonical decomposition will be called an *admissible subsurface* of  $\mathcal{S}_{0,\infty}$ . The *type* of such a subsurface  $S$  is the number of connected components in its boundary. The *tree of  $S$*  is the trace of  $\mathcal{T}_2$  on  $S$ . Clearly, the type of  $S$  is equal to the number of leaves of its tree.

**Definition 2.4** (following [84] and [50]). A homeomorphism  $\varphi$  of  $\mathcal{S}_{0,\infty}$  is *asymptotically rigid* if there exist two admissible subsurfaces  $S_0$  and  $S_1$  having

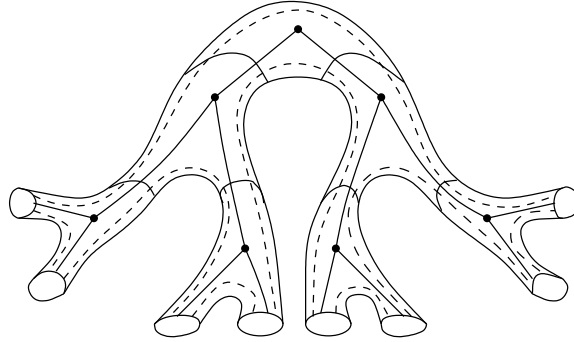
Figure 3. Surface  $\mathcal{S}_{0,\infty}$  with its canonical rigid structure

the same type, such that  $\varphi(S_0) = S_1$  and whose restriction  $\mathcal{S}_{0,\infty} \setminus S_0 \rightarrow \mathcal{S}_{0,\infty} \setminus S_1$  is rigid, meaning that it maps each pants (of the canonical pants decomposition) onto a pants.

The *asymptotically rigid mapping class group* of  $\mathcal{S}_{0,\infty}$  is the group of isotopy classes of asymptotically rigid homeomorphisms.

Though the proof of the following theorem is easy, this theorem is seminal as it is the starting point of a deeper study of the links between Thompson's groups and mapping class groups.

**Theorem 2.2** ([84], Theorem 3.3). *Thompson's group  $T$  can be embedded into the group of isotopy classes of orientation-preserving homeomorphisms of  $\mathcal{S}_{0,\infty}$ . An isotopy class belongs to the image of the embedding if it may be represented by an asymptotically rigid homeomorphism of  $\mathcal{S}_{0,\infty}$  which globally preserves the decomposition into visible/hidden sides.*

We denote by  $\mathcal{S}_{0,\infty}^+$  the visible side of  $\mathcal{S}_{0,\infty}$ . This is a planar surface which inherits from the canonical decomposition of  $\mathcal{S}_{0,\infty}$  a decomposition into hexagons (and one rectangle, corresponding to the visible side of the cylinder). We could restate the above definitions by replacing pairs of pants by hexagons and the surface  $\mathcal{S}_{0,\infty}$  by its visible side  $\mathcal{S}_{0,\infty}^+$ . Then Theorem 2.2 states that  $T$  can be embedded into the mapping class group of the *planar* surface  $\mathcal{S}_{0,\infty}^+$ . In fact  $T$  is the *asymptotically rigid mapping class group* of  $\mathcal{S}_{0,\infty}^+$ , namely the group of mapping classes of those homeomorphisms of  $\mathcal{S}_{0,\infty}^+$  which map all but finitely many hexagons onto hexagons.

## 2.4 Braid groups and Thompson groups

A seminal result, which is the starting point of the article [84], is a theorem of P. Greenberg and the third author ([68]). It states that there exists an extension of the derived subgroup  $F'$  of Thompson's group  $F$  by the stable braid group  $B_\infty$  (i.e. the braid group on a countable set of strands)

$$1 \rightarrow B_\infty \longrightarrow A \longrightarrow F' \rightarrow 1 \quad (Gr - Se),$$

where the group  $A$  is acyclic, i.e. its integral homology vanishes. The existence of such a relation between Thompson's group and the braid group was conjectured by comparing their homology types. On the one hand, it is proved in [63] that  $F'$  has the homology of  $\Omega S^3$ , the space of based loops on the three-dimensional sphere. More precisely, the  $+$ -construction of the classifying space  $BF'$  is homotopically equivalent to  $\Omega S^3$ . On the other hand, F. Cohen proved that  $B_\infty$  has the homology of  $\Omega^2 S^3$ , the double loop space of  $S^3$ . It turns out that both spaces ( $\Omega S^3$  and  $\Omega^2 S^3$ ) are related by the path fibration

$$\Omega^2 S^3 \hookrightarrow P(\Omega S^3) \rightarrow \Omega S^3,$$

where  $P(\Omega S^3)$  denotes the space of based paths on  $\Omega S^3$ . The total space of this fibration,  $P(\Omega S^3)$ , is contractible. Therefore, the existence of this natural fibration has led the authors of [68] to conjecture the existence of the short exact sequence  $(Gr - Se)$ .

The construction of  $A$  amounts to giving a morphism  $F' \rightarrow \text{Out}(B_\infty)$ . In [68] one is lead to consider an extended binary tree and the braid group relative to its vertices. The group  $F'$  acts on that tree by partial automorphisms and therefore induces the desired morphism.

Let us give a hint on how the acyclicity of  $A$  is proved in [68]. Via direct computations, one shows that  $H_1(A) = 0$ . One then proves that the fibration

$$BB_{\infty+} \rightarrow BA_+ \rightarrow BF'_+$$

can be delooped to a fibration

$$\Omega S^3 \rightarrow E \rightarrow S^3$$

Using the fact that  $A$  is perfect one concludes that the space  $E$  is contractible and so  $A$  is acyclic.

As a matter of fact, it is also proved in [68] that the short exact sequence  $(Gr - Se)$  extends to the Thompson group  $T$ . Indeed, there exists a short exact sequence

$$1 \rightarrow B_\infty \longrightarrow A_T \longrightarrow T \rightarrow 1$$

whose pull-back via the embedding  $F' \hookrightarrow T$  is  $(Gr - Se)$ . At the homology level, it corresponds to a fibration

$$\Omega^2 S^3 \rightarrow S^3 \times \mathbb{C}P^\infty \rightarrow \mathcal{L}S^3$$

where  $\mathcal{L}S^3$  denotes the free non-parametrized loop space of  $S^3$ . This fact should not be considered as anecdotal for the following reason. Let us divide the groups  $B_\infty$  and  $A_T$  by the derived subgroup of  $B_\infty$ . One obtains a central extension of  $T$  by  $\mathbb{Z} = H_1(B_\infty)$ , which may be identified in the second cohomology group  $H^2(T, \mathbb{Z})$  to the *discrete Godbillon-Vey class* of Thompson's group  $T$ .

Let us emphasize that a simpler version of  $A_T$ , namely the braided Ptolemy-Thompson group  $T^*$ , will be presented later. Retrospectively,  $A_T$  could be called then the marked braided Ptolemy-Thompson group.

One of the motivations of [84] is to pursue the investigations about the analogies between the diffeomorphism group of the circle  $\text{Diff}(S^1)$  and Thompson's group  $T$ . A remarkable aspect of this analogy concerns the Bott-Virasoro-Godbillon-Vey class. The latter is a differentiable cohomology class of degree 2. Recall that the Lie algebra of the group  $\text{Diff}(S^1)$  is the algebra  $\text{Vect}(S^1)$  of vector fields on the circle. There is a map  $H^*(\text{Diff}(S^1), \mathbb{R}) \rightarrow H^*(\text{Vect}(S^1), \mathbb{R})$ , where the right hand-side denotes the Gelfand-Fuchs cohomology of  $\text{Vect}(S^1)$ , which is simply induced by the differentiation of cocycles. The image of the Bott-Virasoro-Godbillon-Vey class is a generator of  $H^2(\text{Vect}(S^1), \mathbb{R})$  corresponding to the universal central extension of  $\text{Vect}(S^1)$ , known by the physicists as the *Virasoro Algebra*.

Let us explain the analogies between the cohomologies of  $T$  and  $\text{Diff}(S^1)$ . By the cohomology of  $T$  we mean Eilenberg-McLane cohomology, while the cohomology under consideration on  $\text{Diff}(S^1)$  is the differentiable one (as very little is known about its Eilenberg-McLane cohomology). The striking result is the following: the ring of cohomology of  $T$  (with real coefficients) and the ring of differentiable cohomology of  $\text{Diff}(S^1)$  are isomorphic. Both are generated by two classes of degree 2: the Euler class (coming from the action on the circle), and the Bott-Virasoro-Godbillon-Vey class. In the cohomology ring of  $T$ , the Bott-Virasoro-Godbillon-Vey class is called the *discrete Godbillon-Vey class*. The isomorphism between the two cohomology rings does not seem to be induced by known embeddings of  $T$  into  $\text{Diff}(S^1)$  (such embeddings have been constructed in [63]).

A fundamental aspect of the Godbillon-Vey class concerns its relations with the projective representations of  $\text{Diff}(S^1)$ , especially those which may be derived into highest weight modules of the Virasoro Algebra. Pressley and Segal ([110]) introduced some representations  $\rho$  of  $\text{Diff}(S^1)$  in the *restricted* linear group  $\text{GL}_{res}$  of the Hilbert space  $L^2(S^1)$ . Pulling back by  $\rho$  a certain cohomology class (which we refer to as the *Pressley-Segal class*) of  $\text{GL}_{res}$ , one obtains on

$\text{Diff}(S^1)$  some multiples of the Godbillon-Vey class (cf. [84], §4.1.3 for a precise statement).

## 2.5 Extending the Burau representation

In [84], we show that an analogous scenario exists for the discrete Godbillon-Vey class  $\bar{g}v$  of  $T$ . We first remark that the Pressley-Segal extension of  $\text{GL}_{res}$  is itself a pull-back of

$$1 \rightarrow \mathbb{C}^* \rightarrow \frac{\text{GL}(\mathfrak{H})}{\mathfrak{T}_1} \rightarrow \frac{\text{GL}(\mathfrak{H})}{\mathfrak{T}} \rightarrow 1$$

where  $\text{GL}(\mathfrak{H})$  denotes the group of bounded invertible operators of the Hilbert space  $\mathfrak{H}$ ,  $\mathfrak{T}$  the group of operators having a determinant, and  $\mathfrak{T}_1$  the subgroup of operators having determinant 1.

The first step is to reconstruct the group  $A_T$ , not in a combinatorial way as in [68], but as a mapping class group of a surface  $\mathcal{S}_{0,\infty}^t$ . The latter is obtained from  $\mathcal{S}_{0,\infty}$ , by gluing, on each pair of pants of its canonical decomposition, an infinite cylinder or “tube”, marked with countably many punctures (cf. Figure 4). The precise definition of the group  $A_T$  being rather technical, we refer for that the reader to [84].

This new approach provides a setting that is convenient for an easy extension of the Burau representation of the braid group to  $A_T$ . We proceed as follows. The group  $A_T$  acts on the fundamental group of the punctured surface  $\mathcal{S}_{0,\infty}^t$ , which is a free group of infinite countable rank. Moreover, the action is index-preserving, i.e. it induces the identity on  $H_1(F_\infty)$ . Let  $\text{Aut}^{ind}(F_\infty)$  be the group of automorphisms of  $F_\infty$  which are index-preserving. The Magnus representation of  $\text{Aut}^{ind}(F_n)$  extends to an infinite dimensional representation of  $\text{Aut}^{ind}(F_\infty)$  in the Hilbert space  $\ell_2$  on the set of punctures of  $\mathcal{S}_{0,\infty}^t$ . Composing with the map  $A_T \rightarrow \text{Aut}^{ind}(F_\infty)$ , one obtains a representation  $\rho_\infty^t : A_T \rightarrow \text{GL}(\ell^2)$  which extends the classical Burau representation of the braid group  $B_n$ . The scalar  $t \in \mathbb{C}^*$  parameterizes a family of such representations.

**Theorem 2.3** ([84], Theorem 4.7). *For each  $\mathbf{t} \in \mathbb{C}^*$ , the Burau representation  $\rho_\infty^{\mathbf{t}} : B_\infty \rightarrow \mathfrak{T}$  extends to a representation  $\rho_\infty^{\mathbf{t}}$  of the mapping class group  $A_T$  in the Hilbert space  $\ell^2$  on the set of punctures  $\mathcal{S}_{0,\infty}^t$ . There exists a morphism of extensions*

$$\begin{array}{ccccccc} 1 & \longrightarrow & B_\infty & \longrightarrow & A_T & \longrightarrow & T & \longrightarrow & 1 \\ & & \downarrow & & \downarrow & & \downarrow & & \\ 1 & \longrightarrow & \mathfrak{T} & \longrightarrow & \text{GL}(\ell^2) & \longrightarrow & \frac{\text{GL}(\ell^2)}{\mathfrak{T}} & \longrightarrow & 1 \end{array}$$

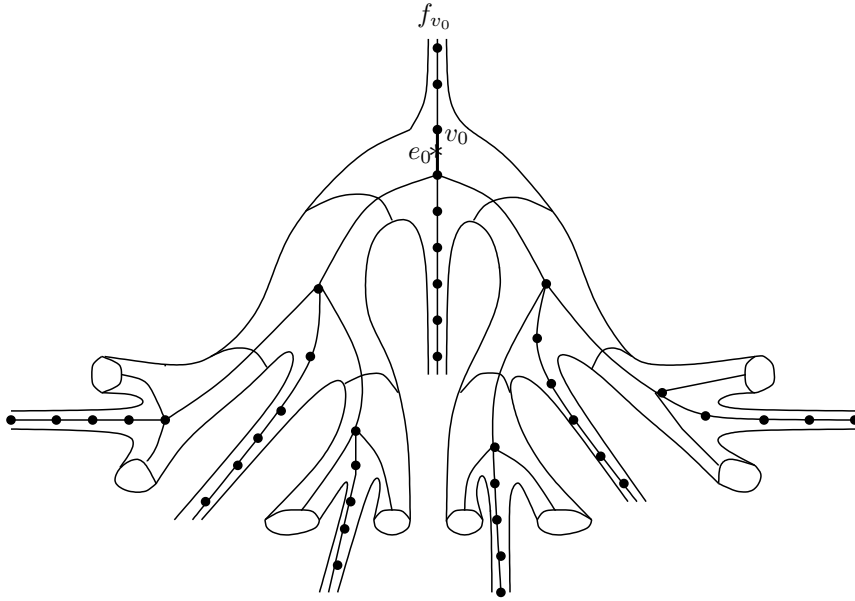
Figure 4. Decomposition of  $\mathcal{S}_{0,\infty}^t$  into pants with tubes

which induces a morphism of central extensions

$$\begin{array}{ccccccc}
 1 & \rightarrow & H_1(B_\infty) & \rightarrow & \frac{A_T}{[B_\infty, B_\infty]} & \rightarrow & T \rightarrow 1 \\
 & & \downarrow & & \downarrow & & \downarrow \\
 1 & \rightarrow & \mathbb{C}^* & \rightarrow & \frac{\mathrm{GL}(\ell^2)}{\mathfrak{I}_1} & \rightarrow & \frac{\mathrm{GL}(\ell^2)}{\mathfrak{I}} \rightarrow 1
 \end{array}$$

The vertical arrows are injective if  $\mathfrak{t} \in \mathbb{C}^*$  is not a root of unity.

### 3 From the Ptolemy groupoid to the Hatcher-Thurston complex

#### 3.1 Universal Teichmüller theory according to Penner

In [108] (see also [109]), R. Penner introduced his version of a universal Teichmüller space, together with an associated universal group. Unexpectedly, this group happens to be isomorphic to the Thompson group  $T$ . This connection between Thompson groups and Teichmüller theory plays a key role in

[50], [51] and [52]. It is therefore appropriate to give some insight into Penner's approach.

The universal Teichmüller space according to Penner is a set  $\mathcal{T}ess$  of ideal tessellations of the Poincaré disk, modulo the action of  $\mathrm{PSL}(2, \mathbb{R})$  (cf. Definition 3.1 below). The space  $\mathcal{T}ess$  is homogeneous under the action of the group  $\mathrm{Homeo}^+(S^1)$  of orientation-preserving homeomorphisms of the circle:

$$\mathcal{T}ess = \mathrm{Homeo}^+(S^1)/\mathrm{PSL}(2, \mathbb{R}).$$

Denoting by  $\mathrm{Diff}^+(S^1)$  the diffeomorphism group of  $S^1$  and  $\mathrm{Homeo}_{qs}(S^1)$  the group of quasi-symmetric homeomorphisms of  $S^1$  (a quasi-symmetric homeomorphism of the circle is induced by a quasi-conformal homeomorphism of the disk) one has the following inclusions

$$\mathrm{Diff}^+(S^1)/\mathrm{PSL}(2, \mathbb{R}) \hookrightarrow \mathrm{Homeo}_{qs}(S^1)/\mathrm{PSL}(2, \mathbb{R}) \hookrightarrow \mathrm{Homeo}^+(S^1)/\mathrm{PSL}(2, \mathbb{R}),$$

which justify that  $\mathcal{T}ess$  is a generalization of the “well known” universal Teichmüller spaces, namely Bers' space  $\mathrm{Homeo}_{qs}(S^1)/\mathrm{PSL}(2, \mathbb{R})$ , and the physicists' space  $\mathrm{Diff}^+(S^1)/\mathrm{PSL}(2, \mathbb{R})$ .

Moreover, Penner introduced some coordinates on  $\mathcal{T}ess$ , as well as a “formal” symplectic form, whose pull-back on  $\mathrm{Diff}^+(S^1)/\mathrm{PSL}(2, \mathbb{R})$  is the Kostant-Kirillov-Souriau form.

**Definition 3.1** (following [108] and [109]). Let  $\mathbb{D}$  be the Poincaré disk. A *tessellation* of  $\mathbb{D}$  is a locally finite and countable set of complete geodesics on  $\mathbb{D}$  whose endpoints lie on the boundary circle  $S^1_\infty = \partial\mathbb{D}$  and are called vertices. The geodesics are called *arcs* or *edges*, forming a triangulation of  $\mathbb{D}$ . A *marked tessellation* of  $\mathbb{D}$  is a pair made of a tessellation plus a distinguished oriented edge (abbreviated d.o.e.)  $\vec{a}$ . One denotes by  $\mathcal{T}ess'$  the set of marked tessellations.

Consider the basic ideal triangle having vertices at  $1, -1, \sqrt{-1} \in S^1_\infty$  in the unit disk model  $\mathbb{D}$ . The orbits of its sides by the group  $\mathrm{PSL}(2, \mathbb{Z})$  is the so-called *Farey tessellation*  $\tau_0$ , as drawn in Figure 5. Its ideal vertices are the rational points of  $\partial\mathbb{D}$ . The marked Farey tessellation has its distinguished oriented edge  $\vec{a}_0$  joining -1 to 1.

The group  $\mathrm{Homeo}^+(S^1)$  acts on the left on  $\mathcal{T}ess'$  in the following way. Let  $\gamma$  be an arc of a marked tessellation  $\tau$ , with endpoints  $x$  and  $y$ , and  $f$  be an element of  $\mathrm{Homeo}^+(S^1)$ ; then  $f(\gamma)$  is defined as the geodesic with endpoints  $f(x)$  and  $f(y)$ . If  $\gamma$  is oriented from  $x$  to  $y$ , then  $f(\gamma)$  is oriented from  $f(x)$  to  $f(y)$ . Finally,  $f(\tau)$  is the marked tessellation  $\{f(\gamma), \gamma \in \tau\}$ . Viewing

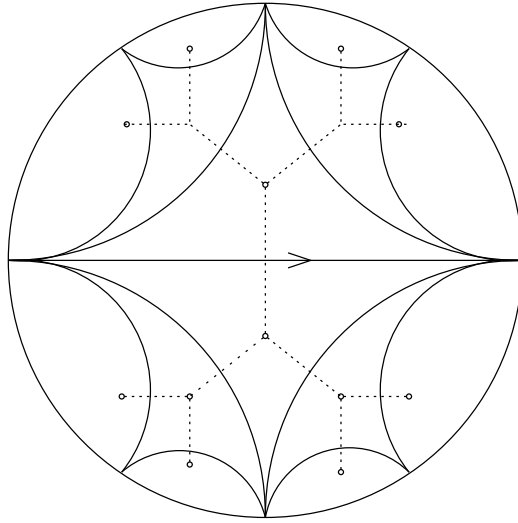

Figure 5. Farey tessellation and its dual tree

$\mathrm{PSL}(2, \mathbb{R})$  as a subgroup of  $\mathrm{Homeo}^+(S^1)$ , one defines  $\mathcal{Tess}$  as the quotient space  $\mathcal{Tess}'/\mathrm{PSL}(2, \mathbb{R})$ .

For any  $\tau \in \mathcal{Tess}'$ , let us denote by  $\tau^0$  its set of ideal vertices. It is a countable and dense subset of the boundary circle, so that it may be proved that there exists a unique  $f \in \mathrm{Homeo}^+(S^1)$  such that  $f(\tau_0) = \tau$ . One denotes this homeomorphism  $f_\tau$ . The resulting map

$$\mathcal{Tess}' \longrightarrow \mathrm{Homeo}^+(S^1), \quad \tau \mapsto f_\tau$$

is a bijection. It follows that  $\mathcal{Tess} = \mathrm{Homeo}^+(S^1)/\mathrm{PSL}(2, \mathbb{R})$ .

Since the action of  $\mathrm{PSL}(2, \mathbb{R})$  is 3-transitive, each element of  $\mathcal{Tess}$  can be uniquely represented by its *normalized marked triangulation* containing the basic ideal triangle and whose d.o.e. is  $\vec{a}_0$ .

The marked tessellation is of Farey-type if its canonical marked triangulation has the same vertices and all but finitely many triangles (or sides) as the Farey triangulation. Unless explicitly stated otherwise all tessellations considered in the sequel will be Farey-type tessellations. In particular, the ideal triangulations have the same vertices as  $\tau_0$  and coincide with  $\tau_0$  for all but finitely many ideal triangles.

### 3.2 The isomorphism between Ptolemy and Thompson groups

**Definition 3.2** (Ptolemy groupoid). The objects of the (*universal*) *Ptolemy groupoid*  $Pt$  are the marked tessellations of Farey-type. The morphisms are ordered pairs of marked tessellations modulo the common  $\mathrm{PSL}(2, \mathbb{R})$  action.

We now define particular elements of  $Pt$  called flips. Let  $e$  be an edge of the marked tessellation represented by the normalized marked triangulation  $(\tau, \vec{a})$ . The result of the flip  $F_e$  on  $\tau$  is the triangulation  $F_e(\tau)$  obtained from  $\tau$  by changing only the two neighboring triangles containing the edge  $e$ , according to the picture below:

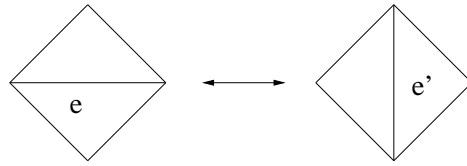

This means that we remove  $e$  from  $\tau$  and then add the new edge  $e'$  in order to get  $F_e(\tau)$ . In particular there is a natural correspondence  $\phi : \tau \rightarrow F_e(\tau)$  sending  $e$  to  $e'$  and being the identity on all other edges. The result of a flip is the new triangulation together with this edge correspondence.

If  $e$  is not the d.o.e. of  $\tau$  then  $F_e(\vec{a}) = \vec{a}$ . If  $e$  is the d.o.e. of  $\tau$  then  $F_e(\vec{a}) = \vec{e}'$ , where the orientation of  $\vec{e}'$  is chosen so that the frame  $(\vec{e}, \vec{e}')$  is positively oriented.

We define now the flipped tessellation  $F_e((\tau, \vec{a}))$  to be the tessellation  $(F_e(\tau), F_e(\vec{a}))$ . It is proved in [108] that flips generate the Ptolemy groupoid i.e. any element of  $Pt$  is a composition of flips.

There is also a slightly different version of the Ptolemy groupoid which is quite useful in the case where we consider Teichmüller theory for surfaces of finite type. Specifically, we should assume that the tessellations are *labelled*, namely that their edges are indexed by natural numbers.

**Definition 3.3** (Labelled Ptolemy groupoid). The objects of the *labelled (universal) Ptolemy groupoid*  $\widetilde{Pt}$  are the labelled marked tessellations. The morphisms between two objects  $(\tau_1, \vec{a}_1)$  and  $(\tau_2, \vec{a}_2)$  are *eventually trivial* permutation maps (at the labels level)  $\phi : \tau_1 \rightarrow \tau_2$  such that  $\phi(\vec{a}_1) = \vec{a}_2$ . When marked tessellations are represented by their normalized tessellations, the latter coincide for all but finitely many triangles. Recall that  $\phi$  is said to be eventually trivial if the induced correspondence at the level of the labelled tessellations is the identity for all but finitely many edges.

Now flips make sense as elements of the labelled Ptolemy groupoid  $\widetilde{Pt}$ . Indeed the flip  $F_e$  is endowed with the natural eventually trivial permutation  $\phi : \tau \rightarrow F_e(\tau)$  sending  $e$  to  $e'$  and being the identity for all other edges.

There is a standard procedure for converting a groupoid into a group, by using an a priori identification of all objects of the category. Here is how this goes in the case of the Ptolemy groupoid. For any marked tessellation  $(\tau, \vec{a})$  there is a characteristic map  $Q_\tau : \mathbb{Q} - \{-1, 1\} \rightarrow \tau$ . Assume that  $\tau$  is the canonical triangulation representing this tessellation. We first label by  $\mathbb{Q} \cup \infty$  the vertices of  $\tau$ , by induction:

- (1)  $-1$  is labelled by  $0/1$ ,  $1$  is labelled by  $\infty = 1/0$  and  $\sqrt{-1}$  is labelled by  $-1/1$ .
- (2) If we have a triangle in  $\tau$  having two vertices already labelled by  $a/b$  and  $c/d$  then its third vertex is labelled  $(a+c)/(b+d)$ . Notice that vertices in the upper half-plane are labelled by negative rationals and those from the lower half-plane by positive rationals.

As it is well-known this labeling produces a bijection between the set of vertices of  $\tau$  and  $\mathbb{Q} \cup \infty$ .

Let now  $e$  be an edge of  $\tau$ , which is different from  $\vec{a}$ . Let  $v(e)$  be the vertex opposite to  $e$  of the triangle  $\Delta$  of  $\tau$  containing  $e$  in its frontier and lying in the component of  $\mathbb{D} - e$  which does not contain  $\vec{a}$ . We then associate to  $e$  the label of  $v(e)$ . We also give  $\vec{a}$  the label  $0 \in \mathbb{Q}$ . In this way one obtains a bijection  $Q_\tau : \mathbb{Q} - \{-1, 1\} \rightarrow \tau$ .

Remark that if  $(\tau_1, \vec{a}_1)$  and  $(\tau_2, \vec{a}_2)$  are marked tessellations then there exists a unique map  $f$  between their vertices sending triangles to triangles and marking on marking. Then  $f \circ Q_{\tau_1} = Q_{\tau_2}$ .

The role played by  $Q_\tau$  is to allow flips to be indexed by the rationals and not by the edges of  $\tau$ .

**Definition 3.4** (Ptolemy group [108]). Let  $\mathcal{T}$  be the set of marked tessellations of Farey-type. Define the action of the free monoid  $M$  generated by  $\mathbb{Q} - \{-1, 1\}$  on  $\mathcal{T}$  by means of:

$$q \cdot (\tau, \vec{a}) = F_{Q_\tau(q)}(\tau, \vec{a}), \text{ for } q \in \mathbb{Q} - \{-1, 1\}, (\tau, \vec{a}) \in \text{FT}.$$

We set  $f \sim f'$  on  $M$  if the two actions of  $f$  and  $f'$  on  $\mathcal{T}$  coincide. Then the induced composition law on  $M/\sim$  is a monoid structure for which each element has an inverse. This makes  $M/\sim$  a group, which is called the Ptolemy group  $T$  (see [108] for more details).

In particular it makes sense to speak of flips in the present case. It is clear that flips generate the Ptolemy group.

The notation  $T$  for the Ptolemy group is not misleading because this group is isomorphic to the Thompson group  $T$  and for this reason, we preferred to call it the Ptolemy-Thompson group.

Given two marked tessellations  $(\tau_1, \vec{a}_1)$  and  $(\tau_2, \vec{a}_2)$  the above combinatorial isomorphism  $f : \tau_1 \rightarrow \tau_2$  provides a map between the vertices of the tessellations, which are identified with  $P^1(\mathbb{Q}) \subset S_\infty^1$ . This map extends continuously to a homeomorphism of  $S_\infty^1$ , which is piecewise- $\text{PSL}(2, \mathbb{Z})$ . This establishes an isomorphism between the Ptolemy group and the group of piecewise- $\text{PSL}(2, \mathbb{Z})$  homeomorphisms of the circle.

An explicit isomorphism with the group  $T$  in the form introduced above was provided by Lochak and Schneps (see [93]). In order to understand this isomorphism we will need another characterization of the Ptolemy groupoid, as follows.

**Definition 3.5** (Ptolemy groupoid second definition [108, 109]). The universal Ptolemy groupoid  $Pt'$  is the category whose objects are the marked tessellations. As for the morphisms, they are composed of morphisms of two types, called *elementary moves*:

- (1) A-move: it is the data of a pair of marked tessellations  $(\tau_1, \tau_2)$ , where  $\tau_1$  and  $\tau_2$  only differ by the d.o.e. The d.o.e.  $\vec{a}_1$  of  $\tau_1$  is one of the two diagonals of a quadrilateral whose 4 sides belong to  $\tau_1$ . Let us assume that the vertices of this quadrilateral are enumerated in the cyclic direct order by  $x, y, z, t$ , in such a way that  $\vec{a}_1$  is the edge oriented from  $z$  to  $x$ . Let  $\vec{a}_2$  be the other diagonal, oriented from  $t$  to  $y$ . Then,  $\tau_2$  is defined as the marked tessellation  $\tau_1 \setminus \{\vec{a}_1\} \cup \{\vec{a}_2\}$ , with oriented edge  $\vec{a}_2$ .
- (2) B-move: it is the data of a pair of marked tessellations  $(\tau_1, \tau_2)$ , where  $\tau_1$  and  $\tau_2$  have the same edges, but only differ by the choice of the d.o.e. The marked edge  $\vec{a}_1$  is the side of the unique triangle of the tessellation  $\tau_1$  with ideal vertices  $x, y, z$ , enumerated in the direct order, in such a way that  $\vec{a}_1$  is the edge from  $x$  to  $y$ . Let  $\vec{a}_2$  be the edge oriented from  $y$  to  $z$ . Then,  $\vec{a}_2$  is the d.o.e. of  $\tau_2$ .

Relations between morphisms: if  $\tau_1$  and  $\tau_2$  are two marked tessellations such that there exist two sequences of elementary moves  $(M_1, \dots, M_k)$  and  $(M'_1, \dots, M'_{k'})$  connecting  $\tau_1$  to  $\tau_2$ , then the morphisms  $M_k \circ \dots \circ M_1$  and  $M'_{k'} \circ \dots \circ M'_1$  are equal.

*Remark 3.1.* Given two marked tessellations  $\tau_1$  and  $\tau_2$  with the same sets of endpoints, there is a (non-unique) finite sequence of elementary moves connecting  $\tau_1$  to  $\tau_2$  if and only if  $\tau_1$  and  $\tau_2$  only differ by a finite number of edges.

From the above remark, it follows that  $Pt'$  is not a connected groupoid. Let  $Pt = Pt'_\mathbb{Q}$  be the connected component of the Farey tessellation. It is the

full sub-groupoid of  $Pt'$  obtained by restricting to the tessellations whose set of ideal vertices are the rationals of the boundary circle  $\partial\mathbb{D}$ , and which differ from the Farey tessellation by only finitely many edges, namely the Farey-type tessellations. Then it is not difficult to prove that the two definitions of  $Pt$  are actually equivalent. However the second definition makes the Lochak-Schneps isomorphism more transparent.

*Construction of the universal Ptolemy group*

Let  $W$  be a symbol  $A$  or  $B$ . For any  $\tau \in Ob(Pt')$ , let us define the object  $W(\tau)$ , which is the target of the morphism of type  $W$ , whose source is  $\tau$ . For any sequence  $W_1, \dots, W_k$  of symbols  $A$  or  $B$ , let us use the notation  $W_k \cdots W_2 W_1(\tau)$  for  $W_k(\dots W_2(W_1(\tau))\dots)$ . Let  $M$  be the free group on  $\{A, B\}$ . Let us fix a tessellation  $\tau$  (the construction will not depend on this choice). Let  $K$  be the subgroup of  $M$  made of the elements  $W_k \cdots W_2 W_1$  such that  $W_k \cdots W_2 W_1(\tau) = \tau$  (it can be easily checked that this implies  $W_k \cdots W_2 W_1(\tau') = \tau'$  for any  $\tau \in Ob(Pt')$ , and that  $K$  is a normal subgroup of  $M$ ).

**Definition 3.6** ([108], [109]). The group  $G = M/K$  is called the *universal Ptolemy group*.

**Theorem 3.2** (Imbert-Kontsevich-Sergiescu, [78]). *The universal Ptolemy group  $G$  is anti-isomorphic to the Thompson group  $T$ , which will be henceforth also called the Ptolemy-Thompson group in order to emphasize this double origin.*

Let us indicate a proof that relies on the definition of  $T$  as a group of bijections of the boundary of the dyadic tree. Let  $\tau \in Pt$ , and let  $T_\tau$  be the regular (unrooted) dyadic tree which is dual to the tessellation  $\tau$ .

Let  $e_\tau$  be the edge of  $T_\tau$  which is transverse to the oriented edge  $\vec{a}_\tau$  of  $\tau$ . The edge  $e_\tau$  is oriented in such a way that  $(\vec{a}_\tau, \vec{e}_\tau)$  is directly oriented in the disk. For each pair  $(\tau, \tau')$  of marked tessellations of  $Pt$ , let  $\varphi_{\tau, \tau'} \in Isom(T_\tau, T_{\tau'})$  be the unique isomorphism of planar oriented trees which maps the oriented edge  $\vec{e}_\tau$  onto the oriented edge  $\vec{e}_{\tau'}$ . As a matter of fact, the planar trees  $T_\tau$  and  $T_{\tau'}$  coincide outside two finite subtrees  $t_\tau$  and  $t_{\tau'}$  respectively, so that their boundaries  $\partial T_\tau$  and  $\partial T_{\tau'}$  may be canonically identified. Therefore,  $\varphi_{\tau, \tau'}$  induces a homeomorphism of  $\partial T_{\tau^*}$ , denoted  $\partial\varphi_{\tau, \tau'}$ . Clearly,  $\partial\varphi_{\tau, \tau'}$  belongs to  $T$ , as it is induced on the boundary of the dyadic planar tree by a partial isomorphism which respects the local orientation of the edges.

The map  $g \in G \mapsto \partial\varphi_{\tau_*, g(\tau_*)} \in Homeo(\partial T_{\tau^*})$  has  $T$  as image, and is an anti-isomorphism onto  $T$ .

An explanation for the anti-isomorphism is the following. One has  $\varphi_{\tau_*,gh(\tau_*)} = \varphi_{h(\tau_*),g(h(\tau_*))}\varphi_{\tau_*,h(\tau_*)}$ . Now  $\varphi_{h(\tau_*),g(h(\tau_*))}$  is the conjugate of  $\varphi_{\tau_*,g(\tau_*)}$  by  $\varphi_{\tau_*,h(\tau_*)}$ , hence  $\varphi_{\tau_*,gh(\tau_*)} = \varphi_{\tau_*,h(\tau_*)}\varphi_{\tau_*,g(\tau_*)}$ .

Following [78], it is also possible to construct an anti-isomorphism between  $G$  and  $T$ , when the latter is realized as a subgroup of  $\text{Homeo}^+(S^1)$ , viewing the circle as the boundary of the Poincaré disk.

For each  $g \in G$ , there exists a unique  $f \in \text{Homeo}^+(S^1)$  such that  $f(\tau_*) = g(\tau_*)$ . It is denoted by  $f_g$ . This provides a map  $f : G \rightarrow \text{Homeo}^+(S^1)$ ,  $g \mapsto f_g$ , which is an anti-isomorphism. Indeed, for all  $h$  and  $g$  in  $G$ , the effect of  $h$  on  $\tau = g(\tau_*)$  is the same as the effect of the conjugate  $f_g \circ f_h \circ f_g^{-1}$ , so that  $(hg)(\tau_*) = f_g \circ f_h \circ f_g^{-1}(\tau) = (f_g \circ f_h)(\tau_*)$ . The morphism is injective, since  $f_g = id$  implies that  $g(\tau_*) = \tau_*$ , hence  $g = 1$ .

It is worth mentioning that a new presentation of  $T$  has been obtained in [93], derived from the anti-isomorphism of  $G$  and  $T$ . It uses only two generators  $\alpha$  and  $\beta$ , defined as follows. Let  $\alpha \in T$  be the element induced by  $\varphi_{\tau_0,A,\tau_0}$ , and  $\beta \in T$  induced by  $\varphi_{\tau_0,B,\tau_0}$ .

**Theorem 3.3** ([93]). *The Ptolemy-Thompson group  $T$  is generated by two elements  $\alpha$  and  $\beta$ , with relations:*

$$\alpha^4 = 1, \beta^3 = 1, (\beta\alpha)^5 = 1,$$

$$[\beta\alpha\beta, \alpha^2\beta\alpha\beta\alpha^2] = 1, [\beta\alpha\beta, \alpha^2\beta^2\alpha^2\beta\alpha\beta\alpha^2\beta\alpha^2] = 1.$$

Let us make explicit the relation between the Cayley graph of  $T$ , for the above presentation, and the nerve of the category  $Pt$ .

**Definition 3.7.** Let  $Gr(Pt)$  be the graph whose vertices are the objects of  $Pt$ , and whose edges correspond to the elementary moves of type  $A$  and  $B$ .

From the anti-isomorphism between  $G = M/K$  and  $T$ , it follows easily that  $Gr(Pt)$  is precisely the Cayley graph of Thompson's group  $T$ , for its presentation on the generators  $\alpha$  and  $\beta$ .

We can use the same method to derive a labelled Ptolemy group  $\tilde{T}$  out of the labelled Ptolemy groupoid  $\tilde{Pt}$ . It is not difficult to obtain therefore the following:

**Proposition 3.4.** *We have an exact sequence*

$$1 \rightarrow S_\infty \rightarrow \tilde{T} \rightarrow T \rightarrow 1$$

where  $S_\infty$  is the group of eventually trivial permutations of the labels. Moreover, the group  $\tilde{T}$  is generated by the obvious lifts  $\tilde{\alpha}$  and  $\tilde{\beta}$  of the generators

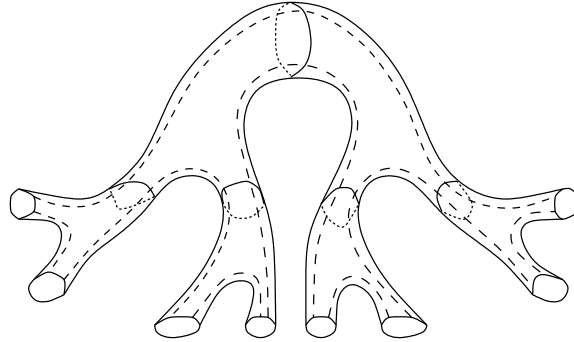
Figure 6. Surface  $\mathcal{S}_{0,\infty}$  with its canonical rigid structure

$\alpha, \beta$  of  $T$ . The pentagon relation now reads  $(\tilde{\beta}\tilde{\alpha})^5 = \sigma_{12}$ , where  $\sigma_{12}$  is the transposition exchanging the labels of the diagonals of the pentagon.

*Remark 3.5.* Let us mention that the image of  $G$  in  $\text{Homeo}^+(S^1)$  by the anti-isomorphism  $f : g \mapsto f_g$  does not correspond to the piecewise dyadic affine version of  $T$ , as recalled in the preliminaries. Let us view here the circle  $S^1$  as the real projective line, and not as the quotient space  $[0, 1]/0 \sim 1$ . Under this identification,  $f(G)$  is the group  $\text{PPSL}(2, \mathbb{Z})$  of orientation preserving homeomorphisms of the projective line, which are piecewise  $\text{PSL}(2, \mathbb{Z})$ , with rational breakpoints. This version of  $T$  is the starting point of a detailed study of the piecewise projective geometry of Thompson's group  $T$ , led in [97] and [98].

### 3.3 A remarkable link between the Ptolemy groupoid and the Hatcher-Thurston complex of $\mathcal{S}_{0,\infty}$ , following [50]

In [50], we give a generalization of the Ptolemy groupoid which uses pairs of pants decompositions of the surface  $\mathcal{S}_{0,\infty}$ .

The surface  $\mathcal{S}_{0,\infty}$  appears in [84] with its "canonical rigid structure" (see also section 2.3). The constructions involved in [50] require to handle not only the canonical rigid structure of  $\mathcal{S}_{0,\infty}$ , but also a set of rigid structures.

**Definition 3.8.** A *rigid structure* on  $\mathcal{S}_{0,\infty}$  consists of the data of a pants decomposition of  $\mathcal{S}_{0,\infty}$  together with a decomposition of  $\mathcal{S}_{0,\infty}$  into two connected components, called the visible and the hidden side, which are compatible in the following sense. The intersection of each pair of pants with the visible or hidden sides of the surface is a hexagon.

The choice of a reference rigid structure defines the *canonical rigid structure* (cf. Figure 6). The dyadic regular (unrooted) tree  $\mathcal{T}_*$  is embedded onto the visible side of  $\mathcal{S}_{0,\infty}$ , as the dual tree to the canonical decomposition (into hexagons).

A rigid structure is *marked* when one of the circles of the decomposition is endowed with an orientation. The choice of a circle of the canonical decomposition and of an orientation of this circle defines the canonical marked rigid structure.

A rigid structure is *asymptotically trivial* if it coincides with the canonical rigid structure outside a compact subsurface of  $\mathcal{S}_{0,\infty}$ .

The set of isotopy classes of (resp. marked) asymptotically trivial rigid structures is denoted  $Rig(\mathcal{S}_{0,\infty})$  (resp.  $Rig'(\mathcal{S}_{0,\infty})$ ).

In [50], we define the *stable groupoid of duality*  $\mathcal{D}_0^s$ , which generalizes  $Pt$ , since it contains a full sub-groupoid isomorphic to  $Pt$ . We first recall the definition of this sub-groupoid, which will be denoted  $\mathcal{D}_{0\mathbb{Q}}^s$ .

**Definition 3.9.** The objects of the groupoid  $\mathcal{D}_{0\mathbb{Q}}^s$  are the asymptotically rigid marked structures of  $\mathcal{S}_{0,\infty}$  whose underlying decomposition into visible and hidden sides is the canonical one.

The morphisms are composed of *elementary morphisms*, called *moves*, of two types,  $A$  and  $B$ .

- (1)  $A$ -move: Let  $r_1$  be an object of  $\mathcal{D}_{0\mathbb{Q}}^s$ . The distinguished oriented circle  $\gamma$  separates two adjacent pairs of pants, whose union is a 4-holed sphere  $\Sigma_{0,4}$ . Up to isotopy, there exists a unique circle contained in  $\Sigma_{0,4}$ , whose geometric intersection number with  $\gamma$  is equal to 2, and which is invariant by the involution  $j$  interchanging the visible and hidden sides. Otherwise stated, the circle  $\gamma'$  is the image of  $\gamma$  by the rotation of angle  $+\frac{\pi}{2}$  described in Figure 7 which stabilizes both sides of  $\mathcal{S}_{0,\infty}$  and  $\Sigma_{0,4}$ . Let  $r_2 = r_1 \setminus \{\gamma\} \cup \{\gamma'\}$ . By definition, the pair  $(r_1, r_2)$  is the  $A$ -move on the rigid marked structure  $r_1$ . Its source is  $r_1$  while  $r_2$  is its target.
- (2)  $B$ -move: Let  $r_1$  be an object of  $\mathcal{D}_{0\mathbb{Q}}^s$ . Let  $P$  be the pair of pants of  $r_1$  bounded by  $\gamma$ , which is on the left when one moves along  $\gamma$  following its orientation. Let  $\gamma''$  be the oriented circle of the boundary of  $P$ , which is the image of the oriented circle  $\gamma$  by the rotation of order 3 and angle  $+\frac{2\pi}{3}$  described on Figure 7 (it stabilizes both sides of  $\mathcal{S}_{0,\infty}$  and  $P$ ). Let  $r_2$  be the pants decomposition whose circles are the same as those of  $r_1$ , but whose distinguished oriented circles is  $\gamma''$ . By definition, the pair  $(r_1, r_2)$  is the  $B$ -move on  $r_1$ . Its source is  $r_1$  while its target is  $r_2$ .

Relations among morphisms: if  $r_1$  and  $r_2$  are two objects of  $\mathcal{D}_{0\mathbb{Q}}^s$  such that there exist two sequences of moves  $(M_1, \dots, M_k)$  and  $(M'_1, \dots, M'_{k'})$  transforming  $r_1$  into  $r_2$ , then  $M_k \circ \dots \circ M_1 = M'_{k'} \circ \dots \circ M'_1$ .

 Figure 7. Moves in the groupoid  $\mathcal{D}_{0,\mathbb{Q}}^s$ 

*Remark 3.6.* There is a bijection between the set of objects of  $Pt$  and the set of objects of  $\mathcal{D}_{0,\mathbb{Q}}^s$ , which maps the *marked Farey tessellation* onto the *canonical marked rigid structure* of  $\mathcal{S}_{0,\infty}$ . This bijection extends to a groupoid isomorphism  $Pt \rightarrow \mathcal{D}_{0,\mathbb{Q}}^s$ .

Via this isomorphism, the generators  $\alpha$  and  $\beta$  may be viewed as isotopy classes of asymptotically rigid homeomorphisms (which preserve the visible/hidden sides decomposition) of  $\mathcal{S}_{0,\infty}$ . The generator  $\alpha$  corresponds to the mapping class such that  $\alpha(r_*) = A(r_*)$ , and  $\beta$  to the mapping class such that  $\beta(r_*) = B(r_*)$ . This gives a new proof of the existence of an embedding of  $T$  into the mapping class group of  $\mathcal{S}_{0,\infty}$ , obtained in [84].

### 3.4 The Hatcher-Thurston complex of $\mathcal{S}_{0,\infty}$

The Hatcher-Thurston complex of pants decompositions is first mentioned in the appendix of [77]. It is defined again in [76], for any compact oriented surface, possibly with boundary, where it is proved that it is simply connected. We extend its definition to the non-compact surface  $\mathcal{S}_{0,\infty}$ .

**Definition 3.10** ([50]). The Hatcher-Thurston complex  $\mathcal{HT}(\mathcal{S}_{0,\infty})$  is a cell 2-complex.

- (1) Its vertices are the asymptotically trivial pants decompositions of  $\mathcal{S}_{0,\infty}$ .
- (2) Its edges correspond to pairs of decompositions  $(p, p')$  such that  $p'$  is obtained from  $p$  by a local  $A$ -move, i.e. by replacing a circle  $\gamma$  of  $p$  by any circle  $\gamma'$  whose geometric intersection number with  $\gamma$  is equal to 2 (and does not intersect the other circles of  $p$ ).
- (3) Its 2-cells fill in the cycles of moves of the following types: triangular cycles, pentagonal cycles (cf. Figure 8), and square cycles corresponding to the commutation of two  $A$ -moves with disjoint supports.

The Hatcher-Thurston complex  $\mathcal{HT}(\mathcal{S}_{0,\infty})$  is an inductive limit of Hatcher-Thurston complexes of compact subsurfaces of  $\mathcal{S}_{0,\infty}$ . It is therefore simply connected.

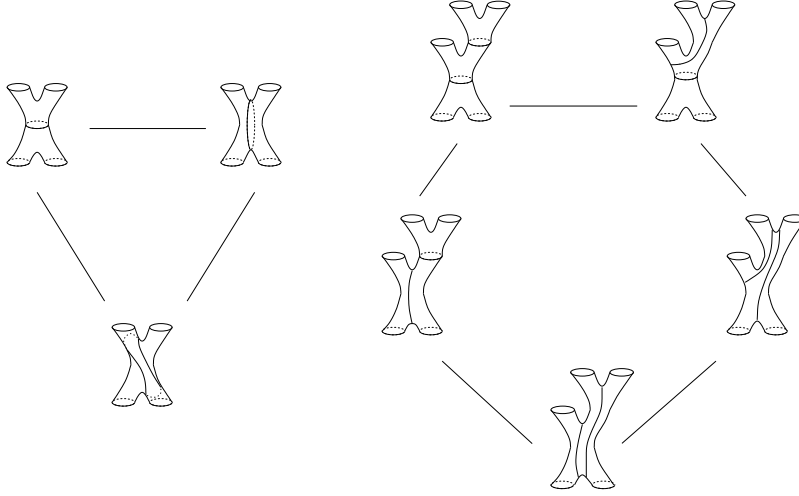
Figure 8. Triangular cycle and pentagonal cycle in  $\mathcal{HT}(\mathcal{S}_{0,\infty})$ 

The following proposition establishes a fundamental relation between the Cayley graph of Thompson's group  $T$  (generated by  $\alpha$  and  $\beta$ ) and the Hatcher-Thurston complex of  $\mathcal{S}_{0,\infty}$ . The presentation of  $T$  will be exploited to prove some useful properties of the Hatcher-Thurston complex.

**Proposition 3.7** (following [50]). *The forgetful map  $Ob(\mathcal{D}_{0,\mathbb{Q}}^s) \rightarrow \mathcal{HT}(\mathcal{S}_{0,\infty})$ , which maps an asymptotically rigid marked structure onto the underlying pants decomposition, extends to a cellular map  $\nu : Gr(\mathcal{D}_{0,\mathbb{Q}}^s) \rightarrow \mathcal{HT}(\mathcal{S}_{0,\infty})$  from the graph of the groupoid onto the 1-skeleton of the Hatcher-Thurston complex. It maps an edge corresponding to an  $A$ -move onto an edge of type  $A$  of  $\mathcal{HT}(\mathcal{S}_{0,\infty})$ , and collapses an edge corresponding to a  $B$ -move onto a vertex.*

Under the isomorphisms  $Gr(\mathcal{D}_{0,\mathbb{Q}}^s) \approx Gr(Pt) \approx Cayl(T)$ , where  $Cayl(T)$  is the Cayley graph of  $T$  with generators  $\alpha$  and  $\beta$ ,  $\nu$  may be identified with a morphism from  $Cayl(T)$  to  $\mathcal{HT}(\mathcal{S}_{0,\infty})$ .

One can easily check that:

- (1) the image by  $\nu$  of the cycle of 10 moves associated to the relation  $(\alpha\beta)^5 = 1$  is a pentagonal cycle of the Hatcher-Thurston complex;
- (2) the image by  $\nu$  of the cycle associated to the relation  $[\beta\alpha\beta, \alpha^2\beta\alpha\beta\alpha^2] = 1$  is a square cycle ( $DC1$ ), corresponding to the commutation of two  $A$ -moves supported by two adjacent 4-holed spheres;
- (3) the image by  $\nu$  of the cycle associated to the relation

$$[\beta\alpha\beta, \alpha^2\beta^2\alpha^2\beta\alpha\beta\alpha^2\beta\alpha^2] = 1$$

is a square cycle ( $DC_2$ ), corresponding to the commutation of two  $A$ -moves supported by two 4-holed spheres separated by a pair of pants.

**Definition 3.11** (Reduced Hatcher-Thurston complex). Let  $\mathcal{HT}_{red}(\mathcal{S}_{0,\infty})$  be the subcomplex of  $\mathcal{HT}(\mathcal{S}_{0,\infty})$ , which differs from the latter by the set of square 2-cells: a square 2-cell of  $\mathcal{HT}(\mathcal{S}_{0,\infty})$  belongs to  $\mathcal{HT}_{red}(\mathcal{S}_{0,\infty})$  if and only if it is of type ( $DC_1$ ) (corresponding to the commutation of  $A$ -moves supported by two adjacent 4-holed spheres), or of type ( $DC_2$ ) (corresponding to the commutation of  $A$ -moves supported by two 4-holed spheres separated by a pair of pants).

**Proposition 3.8** ([50], Proposition 5.5). *The subcomplex  $\mathcal{HT}_{red}(\mathcal{S}_{0,\infty})$  is simply connected.*

We refer to [50] for the proof. It is based on the existence of the morphism of complexes  $\nu$ , and consists in proving, using the presentation of Thompson's group  $T$ , that any square cycle of  $\mathcal{HT}(\mathcal{S}_{0,\infty})$  may be expressed as a product of conjugates of at most three types of cycles: the squares of types ( $DC_1$ ) and ( $DC_2$ ), and the pentagonal cycles.

## 4 The universal mapping class group in genus zero

### 4.1 Definition of the group $\mathcal{B}$

We have seen that  $T$  is isomorphic to the group of mapping classes of asymptotically rigid homeomorphisms of  $\mathcal{S}_{0,\infty}$  which globally preserve the decomposition of the surface into visible/hidden sides. It turns out that if one forgets the last condition, one obtains an interesting larger group, which is the main object of the article [50].

**Definition 4.1** ([50]). The universal mapping class group in genus zero  $\mathcal{B}$  is the group of isotopy classes of (orientation-preserving) homeomorphisms of  $\mathcal{S}_{0,\infty}$  which are asymptotically rigid, namely the asymptotically rigid mapping class group of  $\mathcal{S}_{0,\infty}$  (see also Definition 2.4).

From what precedes,  $T$  imbeds into  $\mathcal{B}$ . As a matter of fact,  $\mathcal{B}$  is an extension of Thompson's group  $V$ .

**Proposition 4.1** ([50], Proposition 2.4). *Let  $K_\infty$  be the pure mapping class group of the surface  $\mathcal{S}_{0,\infty}$ , i.e. the group of mapping classes of homeomorphisms which are compactly supported in  $\mathcal{S}_{0,\infty}$ . There exists a short exact*

sequence

$$1 \rightarrow K_\infty^* \longrightarrow \mathcal{B} \longrightarrow V \rightarrow 1$$

Moreover, the extension splits over  $T \subset V$ .

*Proof.* For the comfort of the reader, we recall the proof given in [50]. Let us define the projection  $\mathcal{B} \rightarrow V$ . Consider  $\varphi \in \mathcal{B}$  and let  $\Sigma$  be a support for  $\varphi$ . We introduce the symbol  $(T_{\varphi(\Sigma)}, T_\Sigma, \sigma(\varphi))$ , where  $T_\Sigma$  (resp.  $T_{\varphi(\Sigma)}$ ) denotes the minimal finite binary subtree of  $\mathcal{T}$  which contains  $q(\Sigma)$  (resp.  $q(\varphi(\Sigma))$ ), and  $\sigma(\varphi)$  is the bijection induced by  $\varphi$  between the set of leaves of both trees. The image of  $\varphi$  in  $V$  is the class of this triple, and it is easy to check that this correspondence induces a well-defined and surjective morphism  $\mathcal{B} \rightarrow V$ . The kernel is the subgroup of isotopy classes of homeomorphisms inducing the identity outside some compact set, and hence is the direct limit of the pure mapping class groups.

Denote by  $\mathbf{T}$  the subgroup of  $\mathcal{B}$  consisting of mapping classes represented by asymptotically rigid homeomorphisms preserving the whole visible side of  $\sigma$ . The image of  $\mathbf{T}$  in  $V$  is the subgroup of elements represented by symbols  $(T_1, T_0, \sigma)$ , where  $\sigma$  is a bijection preserving the cyclic order of the labeling of the leaves of the trees. Thus, the image of  $\mathbf{T}$  is Ptolemy-Thompson's group  $T \subset V$ . Finally, the kernel of the epimorphism  $\mathbf{T} \rightarrow T$  is trivial. In the following, we shall identify  $T$  with  $\mathbf{T}$ .  $\square$

As the kernel of this extension is not finitely generated, there is no evidence that  $\mathcal{B}$  should be finitely generated. The main theorem of [50] asserts a stronger result.

## 4.2 $\mathcal{B}$ is finitely presented

**Theorem 4.2** ([50], Th. 3.1). *The group  $\mathcal{B}$  is finitely presented.*

The proof is geometric, and inspired by the method of Hatcher and Thurston for the presentation of mapping class groups of compact surfaces. It relies on the Bass-Serre theory, as generalized by K. Brown in [18], which asserts the following. Let a group  $G$  act on a simply connected 2-dimensional complex  $X$ , whose stabilizers of vertices are finitely presented, and whose stabilizers of edges are finitely generated. If the set of  $G$ -orbits of cells is finite (otherwise stated, the action is cocompact), then  $G$  is finitely presented.

Clearly, the group  $\mathcal{B}$  acts cellularly on the Hatcher-Thurston complex of  $\mathcal{S}_{0,\infty}$ . However, the idea consisting in exploiting this action must be considerably improved if one wishes to prove the above theorem. Indeed, the complex  $\mathcal{HT}(\mathcal{S}_{0,\infty})$  is simply connected, but it has infinitely many orbits of  $\mathcal{B}$ -cells.

This is due to the existence of the square cycles, corresponding to the commutation of  $A$ -moves on disjoint supports. Let  $\sigma$  be a 2-cell filling in such a square cycle; the  $A$ -moves which commute are supported on two 4-holed spheres, separated by a certain number of pairs of pants  $n_\sigma$ . Clearly, this integer is an invariant of the  $\mathcal{B}$ -orbit of  $\sigma$ , which can be arbitrarily large.

The interest for the reduced Hatcher-Thurston  $\mathcal{HT}_{red}(\mathcal{S}_{0,\infty})$  appears now clearly: it is both simply connected and finite modulo  $\mathcal{B}$ . Unfortunately, the stabilizers of the vertices or edges of  $\mathcal{HT}_{red}(\mathcal{S}_{0,\infty})$  (which are the same as those of  $\mathcal{HT}(\mathcal{S}_{0,\infty})$ ) under the action of  $\mathcal{B}$  are not finitely generated. The idea, in order to overcome this difficulty, is to “rigidify” the pants decompositions so that the size of their stabilizers become more reasonable. This leads us to introduce a complex  $\mathcal{DP}(\mathcal{S}_{0,\infty})$ , whose definition is rather technical (cf. [50], §5), which is a sort of mixing of the Hatcher-Thurston complex, and a certain  $V$ -complex, called the “Brown-Stein complex”, defined in [19]. The latter has been used in [19] to prove that  $V$  has the  $FP_\infty$  property.

Therefore, our  $\mathcal{B}$ -complex  $\mathcal{DP}(\mathcal{S}_{0,\infty})$  encodes simultaneously some finiteness properties of the mapping class groups  $\mathcal{M}(0, n)$  as well as of the Thompson group  $V$ .

With the right complex in hand it is not difficult to find the explicit presentation for  $\mathcal{B}$ , by following the method described in [18].

## 5 The braided Ptolemy-Thompson group

### 5.1 Finite presentation

In the continuity of our investigations on the relations between Thompson groups and mapping class groups of surfaces we introduced and studied a group (in fact two groups which are quite similar) called the braided Ptolemy-Thompson group ([51])  $T^*$ , which might appear as a simplified version of the group  $A_T$  of [68], and studied from a different point of view in [84]. Indeed,  $T^*$ , like  $A_T$ , is an extension of  $T$  by the stable braid group  $B_\infty$ . Its definition is simpler than that of  $A_T$ , and is essentially topological.

**Definition 5.1** (from [51]). (1) Let  $D$  be the planar surface with boundary obtained by thickening the dyadic complete (unrooted) planar tree. The decomposition into hexagons of  $D$ , which is dual to the tree, is called the *canonical decomposition*. By a *separating arc* of the decomposition we mean a connected component of the boundary of a hexagon which is not included in the boundary of  $D$ .

(2) Let  $D^\sharp$  be the surface  $D$  with punctures corresponding to the vertices of the tree, and  $D^*$  the surface  $D$  whose punctures are the middles of

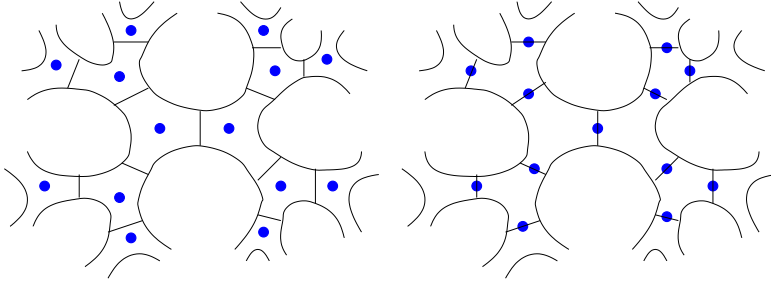

Figure 9.  $D^\sharp$  and  $D^*$  with their canonical rigid structures

the separating arcs of the canonical decomposition (cf. Figure 9). A connected subsurface of  $D^\sharp$  or  $D^*$  is *admissible* if it is the union of finitely many hexagons of the canonical decomposition.

- (3) Let  $D^\diamond$  denote  $D^\sharp$  or  $D^*$ . An orientation-preserving homeomorphism  $g$  of  $D^\diamond$  is *asymptotically rigid* if it preserves globally the set of punctures, and if there exist two admissible subsurfaces  $S_0$  and  $S_1$  such that  $g$  induces by restriction a “rigid” homeomorphism from  $D^\diamond \setminus S_0$  onto  $D^\diamond \setminus S_1$ , i.e. a homeomorphism that respects the canonical decomposition and the punctures.

Note that  $D$  may be identified with the visible side of the surface  $\mathcal{S}_{0,\infty}$  of [84] and [50]. Its canonical decomposition into hexagons is the trace on the visible side of  $\mathcal{S}_{0,\infty}$  of the canonical pants decomposition of the latter.

**Definition 5.2.** The braided Ptolemy-Thompson group  $T^\diamond$  (where the symbol  $\diamond$  may denote either  $*$  or  $\sharp$ ) is the group of isotopy classes of asymptotically rigid homeomorphisms of  $D^\diamond$ .

It is not difficult to see that there exists a short exact sequence

$$1 \rightarrow B_\infty \longrightarrow T^\diamond \longrightarrow T \rightarrow 1.$$

Unlike the extension of  $T$  by  $B_\infty$  which defines  $A_T$ , the above extensions, producing respectively the groups  $T^\sharp$  and  $T^*$ , are not related to the discrete Godbillon-Vey class.

The main result of [51] is a theorem concerning the group presentations.

**Theorem 5.1** ([51], Th. 4.5). *The groups  $T^\sharp$  and  $T^*$  are finitely presented.*

Moreover, an explicit presentation for  $T^\sharp$  is given, with 3 generators. We show that  $T^*$  is generated by 2 elements. By comparing their associated abelianized groups, one proves that  $T^\sharp$  and  $T^*$ , though quite similar, are not isomorphic.

As in [50], we prove the above theorem by making  $T^\sharp$  and  $T^*$  act on convenient simply-connected 2-complexes. The results of §4 are used once again, especially the reduced Hatcher-Thurston complex, by introducing braided versions of the Hatcher-Thurston complex of the surface  $D^\sharp$  and  $D^*$  (the pairs of pants being replaced by hexagons).

In short, a vertex of these two complexes is a decomposition into hexagons which coincides with the canonical decomposition outside a compact subsurface  $D$ , such that:

- (1) in the  $T^\sharp$ -complex each hexagon contains a puncture of  $D^\sharp$  in its interior;
- (2) in the  $T^*$ -complex each separating arc passes through a puncture of  $D^*$ .

There are two types of edges: an  $A$ -move of Hatcher-Thurston, and a braiding move  $B$  (cf. [51], §3). Forgetting the punctures, one obtains fibrations from the complexes onto the Hatcher-Thurston complex of  $D$ , whose fibers over the vertices are isomorphic to the Cayley complex of the stable braid group  $B_\infty$ . The presentation of  $B_\infty$  that is convenient exploits the distribution of the punctures on a tree or a graph. It is given by a more general theorem of the third author (cf. [113]).

The groups  $T^\sharp$  and  $T^*$  share a number of properties which makes them quite different from  $\mathcal{B}$ . For instance the cyclic orderability of  $T$  together with the left orderability of  $B_\infty$  leads to a cyclic order on  $T^*$ . Using a result from [24] we obtain:

**Proposition 5.2** ([51], Prop. 2.13). *The group  $T^*$  can be embedded into the group of orientation-preserving homeomorphisms of the circle.*

Adapting one of the Artin solutions of the word problem in the braid group, we also prove

**Proposition 5.3** ([51], Prop. 2.16). *The word problem for the group  $T^*$  is solvable.*

The group  $T^*$  is also used in the study of an asymptotically rigid mapping class group of infinite genus, whose rational homology is isomorphic to the “stable homology of the mapping class group”.

## 5.2 Asynchronous combability

The aim of this section is to show that  $T^*$  has strong finiteness properties. Although it was known that one can generate Thompson groups using automata ([69]), very little was known about the geometry of their Cayley graphs. Recently, D. Farley proved ([38]) that Thompson groups (and more generally

picture groups, see [73]) act properly by isometries on CAT(0) cubical complexes (and hence are a-T-menable), and V.Guba (see [71, 72]) obtained that the smallest Thompson group  $F$  has quadratic Dehn function while  $T$  and  $V$  have polynomial Dehn functions. It is known that automatic groups have quadratic Dehn functions on one side and Niblo and Reeves ([106]) proved that any group acting properly discontinuously and cocompactly on a CAT(0) cubical complex is automatic. One might therefore wonder whether Thompson groups are automatic.

We approach this problem from the perspective of mapping class groups, since one can view  $T$  and  $T^*$  as mapping class groups of a surface of infinite type. One of the far reaching results in this respect is the Lee Mosher theorem ([104]) stating that mapping class groups of surfaces of finite type are automatic. Our main result in [53] shows that, when shifting to surfaces of infinite type, a slightly weaker result still holds.

We will follow below the terminology introduced by Bridson in [1, 11, 12], in particular we allow very general combings. We refer the reader to [36] for a thorough introduction to the subject.

Let  $G$  be a finitely generated group with a finite generating set  $S$ , such that  $S$  is closed with respect to taking inverses, and  $C(G, S)$  be the corresponding Cayley graph. This graph is endowed with the word metric in which the distance  $d(g, g')$  between the vertices associated to the elements  $g$  and  $g'$  of  $G$  is the minimal length of a word in the generators  $S$  representing the element  $g^{-1}g'$  of  $G$ .

A *combing* of the group  $G$  with generating set  $S$  is a map which associates to any element  $g \in G$  a path  $\sigma_g$  in the Cayley graph associated to  $S$  from 1 to  $g$ . In other words  $\sigma_g$  is a word in the free group generated by  $S$  that represents the element  $g$  in  $G$ . We can also represent  $\sigma_g(t)$  as an infinite edge path in  $C(G, S)$  (called *combing path*) that joins the identity element to  $g$ , moving at each step to a neighboring vertex and which becomes eventually stationary at  $g$ . Denote by  $|\sigma_g|$  the length of the path  $\sigma_g$  i.e. the smallest  $t$  for which  $\sigma_g(t)$  becomes stationary.

**Definition 5.3.** The combing  $\sigma$  of the group  $G$  is *synchronously bounded* if it satisfies the synchronous fellow traveler property defined as follows. There exists  $K$  such that the combing paths  $\sigma_g$  and  $\sigma_{g'}$  of any two elements  $g, g'$  at distance  $d(g, g') = 1$  are at most distance  $K$  apart at each step i.e.

$$d(\sigma_g(t), \sigma_{g'}(t)) \leq K, \text{ for any } t \in \mathbb{R}_+.$$

A group  $G$  having a synchronously bounded combing is called *synchronously combable*.

In particular, combings furnish normal forms for group elements. The existence of combings with special properties (like the fellow traveler property) has important consequences for the geometry of the group (see [1, 11]).

We will also introduce a slightly weaker condition (after Bridson and Gersten) as follows:

**Definition 5.4.** The combing  $\sigma$  of the group  $G$  is *asynchronously bounded* if there exists  $K$  such that for any two elements  $g, g'$  at distance  $d(g, g') = 1$  there exist ways to travel along the combing paths  $\sigma_g$  and  $\sigma_{g'}$  at possibly different speeds so that corresponding points are at most distance  $K$  apart. Thus, there exists continuous increasing functions  $\varphi(t)$  and  $\varphi'(t)$  going from zero to infinity such that

$$d(\sigma_g(\varphi(t)), \sigma_{g'}(\varphi'(t))) \leq K, \text{ for any } t \in \mathbb{R}_+.$$

A group  $G$  having an asynchronously bounded combing is called *asynchronously combable*.

The asynchronously bounded combing  $\sigma$  has a *departure function*  $D : \mathbb{R}_+ \rightarrow \mathbb{R}_+$  if for all  $r > 0, g \in G$  and  $0 \leq s, t \leq |\sigma_g|$ , the assumption  $|s - t| > D(r)$  implies that  $d(\sigma_g(s), \sigma_g(t)) > r$ .

The main result of [53] can be stated as follows:

**Theorem 5.4** ([53]). *The group  $T^*$  is asynchronously combable.*

In particular, in the course of the proof we also prove that:

**Corollary 5.5.** *The Thompson group  $T$  is asynchronously combable.*

The proof is largely inspired by the methods of L. Mosher. The mapping class group is embedded into the Ptolemy groupoid of some triangulation of the surface, as defined by L. Mosher and R. Penner. It suffices then to provide combings for the latter.

*Remark 5.6.* There are known examples of asynchronously combable groups with a departure function: asynchronously automatic groups (see [36]), the fundamental group of a Haken 3-manifold ([11]), or of a geometric 3-manifold ([12]), semi-direct products of  $\mathbb{Z}^n$  by  $\mathbb{Z}$  ([11]). Gersten ([58]) proved that asynchronously combable groups with a departure function are of type  $FP_3$  and announced that they should actually be  $FP_\infty$ . Recall that a group  $G$  is  $FP_n$  if there is a projective  $\mathbb{Z}[G]$ -resolution of  $\mathbb{Z}$  which is finitely generated in dimensions at most  $n$  (see [56], Chapter 8 for a thorough discussion on this topic). Notice that there exist asynchronously combable groups (with departure function) which are not asynchronously automatic, for instance the Sol and Nil geometry groups of closed 3-manifolds (see [10]); in particular, they are not automatic.

## 6 Central extensions of $T$ and quantization

### 6.1 Quantum universal Teichmüller space

The goal of the quantization is, roughly speaking, to obtain *non-commutative deformations* of the action of the mapping class group on the Teichmüller space. It appears that the Teichmüller space of a surface has a particularly nice *global* system of coordinate charts whenever the surface has at least one puncture, the so-called shearing coordinates introduced by Thurston (see [47] for a survey). Each coordinate chart corresponds to fixing the isotopy class of a triangulation of the surface with vertices at the puncture. The mapping class group embeds into the *labelled* Ptolemy groupoid of the surface and there is a natural extension of the mapping class group action to an action of this groupoid on the set of coordinate charts. The necessity of considering labelled triangulations comes from the existence of triangulations with non-trivial automorphism groups. This theory extends naturally to the universal setting of Farey-type tessellations of the Poincaré disk  $\mathbb{D}$ , which behaves naturally as an infinitely punctured surface. Since there are no automorphisms of the binary tree which induce eventually trivial permutations it follows that we do not need labelled tessellations. The analogue of the mapping class group is therefore the Ptolemy-Thompson group  $T$ . We will explain below (see Section 6.2) how one obtains by quantization a projective representation of  $T$ , namely a representation into the linear group modulo scalars, which is called the dilogarithmic representation. One of the main results of [55] (see also Sections 6.4 and 6.5) is the fact that the dilogarithmic representation comes from a central extension of  $T$  whose class is 12 times the Euler class generator. This result is very similar to the case of a finite type surface where the dilogarithmic representations come from a central extension of the mapping class group of a punctured surface having extension class 12 times the Euler class plus the puncture classes (see [54] for details).

Here and henceforth, for the sake of brevity, we will use the term tessellation instead of marked tessellation. For each tessellation  $\tau$  let  $E(\tau)$  be the set of its edges. We associate further a skew-symmetric matrix  $\varepsilon(\tau)$  with entries  $\varepsilon_{ef}$ , for all  $e, f \in E(\tau)$ , as follows. If  $e$  and  $f$  do not belong to the same triangle of  $\tau$  or  $e = f$  then  $\varepsilon_{ef} = 0$ . Otherwise,  $e$  and  $f$  are distinct edges belonging to the same triangle of  $\tau$  and thus have a common vertex. We obtain  $f$  by rotating  $e$  in the plane along that vertex such that the moving edge is sweeping out the respective triangle of  $\tau$ . If we rotate clockwise then  $\varepsilon_{ef} = +1$  and otherwise  $\varepsilon_{ef} = -1$ .

The pair  $(E(\tau), \varepsilon(\tau))$  is called a *seed* in [45]. Observe, that in this particular case seeds are completely determined by tessellations.

Let  $(\tau, \tau')$  be a flip  $F_e$  in the edge  $e \in E(\tau)$ . Then the associated seeds  $(E(\tau), \varepsilon(\tau))$  and  $(E(\tau'), \varepsilon(\tau'))$  are obtained one from another by a *mutation* in the direction  $e$ . Specifically, this means that there is an isomorphism  $\mu_e : E(\tau) \rightarrow E(\tau')$  such that

$$\varepsilon(\tau')_{\mu_e(s)\mu_e(t)} = \begin{cases} -\varepsilon_{st}, & \text{if } e = s \text{ or } e = t, \\ \varepsilon_{st}, & \text{if } \varepsilon_{se}\varepsilon_{et} \leq 0, \\ \varepsilon_{st} + |\varepsilon_{se}|\varepsilon_{et}, & \text{if } \varepsilon_{se}\varepsilon_{et} > 0 \end{cases}$$

The map  $\mu_e$  comes from the natural identification of the edges of the two respective tessellations out of  $e$  and  $F_e(e)$ .

This algebraic setting appears in the description of the universal Teichmüller space  $\mathcal{T}$ . Its formal definition (see [43, 44]) is the set of positive real points of the cluster  $\mathcal{X}$ -space related to the set of seeds above. However, we can give a more intuitive description of it, following [108]. Specifically, this  $\mathcal{T}$  is the space of *all* marked Farey-type tessellations from Section 3.2. Each tessellation  $\tau$  gives rise to a coordinate system  $\beta_\tau : \mathcal{T} \rightarrow \mathbb{R}^{E(\tau)}$ . The real number  $x_e = \beta_\tau(e) \in \mathbb{R}$  specifies the amount of translation along the geodesic associated to the edge  $e$  which is required when gluing together the two ideal triangles sharing that geodesic to obtain a given quadrilateral in the hyperbolic plane. These are called the shearing coordinates (introduced by Thurston and then considered by Bonahon, Fock and Penner) on the universal Teichmüller space and they provide a homeomorphism  $\beta_\tau : \mathcal{T} \rightarrow \mathbb{R}^{E(\tau)}$ . There is an explicit geometric formula (see also [42, 47]) for the shearing coordinates, as follows. Assume that the union of the two ideal triangles in  $\mathbb{H}^2$  is the ideal quadrilateral of vertices  $pp_0p_{-1}p_\infty$  and the common geodesic is  $p_\infty p_0$ . Then the respective shearing coordinate is the cross-ratio

$$x_e = [p, p_0, p_{-1}, p_\infty] = \log \frac{(p_0 - p)(p_{-1} - p_\infty)}{(p_\infty - p)(p_{-1} - p_0)}.$$

Let  $\tau'$  be obtained from  $\tau$  by a flip  $F_e$  and set  $\{x'_f\}$  for the coordinates associated to  $\tau'$ . The map  $\beta_{\tau, \tau'} : \mathbb{R}^{E(\tau')} \rightarrow \mathbb{R}^{E(\tau)}$  given by

$$\beta_{\tau, \tau'}(x'_s) = \begin{cases} x_s - \varepsilon(\tau)_{se} \log(1 + \exp(-\text{sgn}(\varepsilon_{se})x_e)), & \text{if } s \neq e, \\ -x_e, & \text{if } s = e \end{cases}$$

relates the two coordinate systems, namely  $\beta_{\tau, \tau'} \circ \beta_{\tau'} = \beta_\tau$ .

These coordinate systems provide a contravariant functor  $\beta : Pt \rightarrow \text{Comm}$  from the Ptolemy groupoid  $Pt$  to the category  $\text{Comm}$  of commutative topological  $*$ -algebras over  $\mathbb{C}$ . We associate to a tessellation  $\tau$  the algebra  $B(\tau) = C^\infty(\mathbb{R}^{E(\tau)}, \mathbb{C})$  of smooth complex valued functions on  $\mathbb{R}^{E(\tau)}$ , with the  $*$ -structure given by  $*f = \bar{f}$ . Furthermore to any flip  $(\tau, \tau') \in Pt$  one associates the map  $\beta_{\tau, \tau'} : B(\tau') \rightarrow B(\tau)$ .

The matrices  $\varepsilon(\tau)$  have a deep geometric meaning. In fact the bi-vector field

$$P_\tau = \sum_{e,f} \varepsilon(\tau)_{ef} \frac{\partial}{\partial x_e} \wedge \frac{\partial}{\partial x_f}$$

written here in the coordinates  $\{x_e\}$  associated to  $\tau$  defines a Poisson structure on  $\mathcal{T}$  which is invariant by the action of the Ptolemy groupoid. The associated Poisson bracket is then given by the formula

$$\{x_e, x_f\} = \varepsilon(\tau)_{ef}.$$

Kontsevich proved that there is a canonical formal quantization of a (finite dimensional) Poisson manifold. The universal Teichmüller space is not only a Poisson manifold but also endowed with a group action and our aim will be an equivariant quantization. Chekhov, Fock and Kashaev (see [27, 28, 85, 86]) constructed an equivariant quantization by means of explicit formulas. There are two ingredients in their approach. First, the Poisson bracket is given by constant coefficients, in any coordinate charts and second, the quantum (di)logarithm.

To any category  $C$  whose morphisms are  $\mathbb{C}$ -vector spaces one associates its projectivisation  $PC$  having the same objects and new morphisms given by  $\text{Hom}_{PC}(C_1, C_2) = \text{Hom}_C(C_1, C_2)/U(1)$ , for any two objects  $C_1, C_2$  of  $C$ . Here  $U(1) \subset \mathbb{C}$  acts by scalar multiplication. A projective functor into  $C$  is actually a functor into  $PC$ .

Now let  $A^*$  be the category of topological  $*$ -algebras. Two functors  $F_1, F_2 : C \rightarrow A^*$  essentially coincide if there exists a third functor  $F$  and natural transformations  $F_1 \rightarrow F, F_2 \rightarrow F$  providing dense inclusions  $F_1(O) \hookrightarrow F(O)$  and  $F_2(O) \hookrightarrow F(O)$ , for any object  $O$  of  $C$ .

**Definition 6.1.** A *quantization*  $\mathcal{T}^h$  of the universal Teichmüller space is a family of contravariant projective functors  $\beta^h : Pt \rightarrow A^*$  depending smoothly on the real parameter  $h$  such that:

- (1) The limit  $\lim_{h \rightarrow 0} \beta^h = \beta^0$  exists and essentially coincides with the functor  $\beta$ .
- (2) The limit  $\lim_{h \rightarrow 0} [f_1, f_2]/h$  is defined and coincides with the Poisson bracket on  $\mathcal{T}$ . Alternatively, for each  $\tau$  we have a  $\mathbb{C}(h)$ -linear (non-commutative) product structure  $\star$  on the vector space  $C^\infty(\mathbb{R}^{E(\tau)}, \mathbb{C}(h))$  such that

$$f \star g = fg + h\{f, g\} + o(h)$$

where  $\{f, g\}$  is the Poisson bracket on functions on  $\mathcal{T}$  and  $\mathbb{C}(h)$  denotes the algebra of smooth  $\mathbb{C}$ -valued functions on the real parameter  $h$ .

We associate to each tessellation  $\tau$  the *Heisenberg algebra*  $H_\tau^h$  which is the topological  $*$ -algebra over  $\mathbb{C}$  generated by the elements  $x_e, e \in E(\tau)$  subject to the relations

$$[x_e, x_f] = 2\pi i h \varepsilon(\tau)_{ef}, \quad x_e^* = x_e.$$

We then define  $\beta^h(\tau) = H_\tau^h$ .

Quantization should associate a homomorphism  $\beta^h((\tau, \tau')) : H_{\tau'}^h \rightarrow H_\tau^h$  to each element  $(\tau, \tau') \in Pt$ . It actually suffices to consider the case where  $(\tau, \tau')$  is the flip  $F_e$  in the edge  $e \in E(\tau)$ . Let  $\{x'_s\}, s \in E(\tau')$  be the generators of  $H_{\tau'}^h$ . We then set

$$\beta^h((\tau, \tau'))(x'_s) = \begin{cases} x_s - \varepsilon(\tau)_{se} \phi^h(-\text{sgn}(\varepsilon(\tau)_{se})x_e), & \text{if } s \neq e, \\ -x_s, & \text{if } s = e \end{cases}$$

Here  $\phi^h$  is the *quantum logarithm* function, namely

$$\phi^h(z) = -\frac{\pi h}{2} \int_{\Omega} \frac{\exp(-itz)}{\text{sh}(\pi t) \text{sh}(\pi ht)} dt$$

where the contour  $\Omega$  goes along the real axes from  $-\infty$  to  $\infty$  bypassing the origin from above.

Some properties of the quantum logarithm are collected below:

$$\lim_{h \rightarrow 0} \phi^h(z) = \log(1 + \exp(z)), \quad \phi^h(z) - \phi^h(-z) = z,$$

$$\overline{\phi^h(z)} = \phi^h(\bar{z}), \quad \frac{\phi^h(z)}{h} = \phi^{1/h}\left(\frac{z}{h}\right)$$

A convenient way to represent this transformation graphically is to associate to a tessellation its dual binary tree embedded in  $\mathbb{H}^2$  and to assign to each edge  $e$  the respective generator  $x_e$ . Then the action of a flip reads as follows:

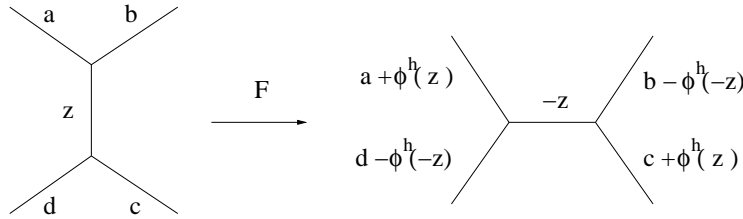

We then have:

**Proposition 6.1** ([27, 46]). *The projective functor  $\beta^h$  is well-defined and it is a quantization of the universal Teichmüller space  $\mathcal{T}$ .*

One proves that  $\beta^h((\tau, \tau'))$  is independent of the decomposition of the element  $(\tau, \tau')$  as a product of flips. In the classical limit  $\hbar \rightarrow 0$  the quantum flip tends to the usual formula of the coordinate change induced by a flip. Thus the first requirement in Definition 6.1 is fulfilled, and the second one is obvious, from the defining relations in the Heisenberg algebra  $H_\tau^h$ .

## 6.2 The dilogarithmic representation of $T$

The subject of this section is to give a somewhat self-contained definition of the dilogarithmic representation of the group  $T$ . The case of general cluster modular groupoids is developed in full detail in [45, 46] and the group  $T$  as a cluster modular groupoid is explained in [44].

The quantization of a physical system in quantum mechanics should provide a Hilbert space and the usual procedure is to consider a Hilbert space representation of the algebra from Definition 6.1. This is formalized in the notion of representation of a quantum space.

**Definition 6.2.** A projective  $*$ -representation of the quantized universal Teichmüller space  $\mathcal{T}^h$ , specified by the functor  $\beta^h : Pt \rightarrow A^*$ , consists of the following data:

- (1) A projective functor  $Pt \rightarrow \text{Hilb}$  to the category of Hilbert spaces. In particular, one associates a Hilbert space  $\mathcal{L}_\tau$  to each tessellation  $\tau$  and a unitary operator  $K_{(\tau, \tau')} : \mathcal{L}_\tau \rightarrow \mathcal{L}_{\tau'}$ , defined up to a scalar of absolute value 1.
- (2) A  $*$ -representation  $\rho_\tau$  of the Heisenberg algebra  $H_\tau^h$  in the Hilbert space  $\mathcal{L}_\tau$ , such that the operators  $\mathbf{K}_{(\tau, \tau')}$  intertwine the representations  $\rho_\tau$  and  $\rho_{\tau'}$  i.e.

$$\rho_\tau(w) = \mathbf{K}_{(\tau, \tau')}^{-1} \rho_{\tau'}(\beta^h((\tau, \tau'))(w)) \mathbf{K}_{(\tau, \tau')}, \quad w \in H_\tau^h.$$

The classical Heisenberg  $*$ -algebra  $H$  is generated by  $2n$  elements  $x_s, y_s$ ,  $1 \leq s \leq n$  and relations

$$[x_s, y_s] = 2\pi i \hbar, \quad [x_s, y_t] = 0, \text{ if } s \neq t, \quad [x_s, x_t] = [y_s, y_t] = 0, \text{ for all } s, t$$

with the obvious  $*$ -structure. The single irreducible integrable  $*$ -representation  $\rho$  of  $H$  makes it act on the Hilbert space  $L^2(\mathbb{R}^n)$  by means of the operators:

$$\rho(x_s)f(z_1, \dots, z_n) = z_s f(z_1, \dots, z_n), \quad \rho(y_s) = -2\pi i \hbar \frac{\partial f}{\partial z_s}.$$

The Heisenberg algebras  $H_\tau^h$  are defined by commutation relations with constant coefficients and hence their representations can be constructed by selecting a Lagrangian subspace in the generators  $x_s$  – called a polarization – and

letting the generators act as linear combinations in the above operators  $\rho(x_s)$  and  $\rho(y_s)$ .

The Stone-von Neumann theorem holds then for these algebras. Specifically, there exists a unique unitary irreducible Hilbert space representation of given central character that is integrable i.e. which can be integrated to the corresponding Lie group. Notice that there exist in general also non-integrable unitary representations.

In particular we obtain representations of  $H_\tau^h$  and  $H_{\tau'}^h$ . The uniqueness of the representation yields the existence of an intertwiner  $\mathbf{K}_{(\tau,\tau')}$  (defined up to a scalar) between the two representations. However, neither the Hilbert spaces nor the representations  $\rho_\tau$  are canonical, as they depend on the choice of the polarization.

We will give below *the construction of a canonical representation* when the quantized Teichmüller space is replaced by its double. We need first to switch to another system of coordinates, coming from the cluster  $\mathcal{A}$ -varieties. Define, after Penner (see [108]), the *universal decorated Teichmüller space*  $\mathcal{A}$  to be the space of all marked tessellations endowed with one horocycle for each vertex (decoration). Alternatively (see [43]),  $\mathcal{A}$  is the set of positive real points of the cluster  $\mathcal{A}$ -space related to the previous set of seeds.

Each tessellation  $\tau$  yields a coordinate system  $\alpha_\tau : \mathcal{A} \rightarrow \mathbb{R}^{E(\tau)}$  which associates to the edge  $e$  of  $\tau$  the coordinate  $a_e = \alpha_\tau(e) \in \mathbb{R}$ . The number  $\alpha_\tau(e)$  is the algebraic distance between the two horocycles on  $\mathbb{H}^2$  centered at vertices of  $e$ , measured along the geodesic associated to  $e$ . These are the so-called *lambda-length* coordinates of Penner.

There is a canonical map  $p : \mathcal{A} \rightarrow \mathcal{T}$  (see [108], Proposition 3.7 and [43]) such that, in the coordinate systems induced by a tessellation  $\tau$ , the corresponding map  $p_\tau : \mathbb{R}^{E(\tau)} \rightarrow \mathbb{R}^{E(\tau)}$  is given by

$$p_\tau \left( \sum_{t \in E(\tau)} \varepsilon(\tau)_{st} a_t \right) = x_s.$$

Let  $(\tau, \tau')$  be the flip on the edge  $e$  and set  $a'_s$  be the coordinates system associated to  $\tau'$ . Then the flip induces the following change of coordinates:

$$\alpha_{\tau,\tau'}(a_s) = a_s, \text{ if } s \neq e$$

$$\alpha_{\tau,\tau'}(a_e) = -a_e + \log \left( \exp \left( \sum_{t; \varepsilon(\tau)_{et} > 0} \varepsilon(\tau)_{et} a_t \right) + \exp \left( - \sum_{t; \varepsilon(\tau)_{et} < 0} \varepsilon(\tau)_{et} a_t \right) \right).$$

It can be verified that  $p_\tau$  are compatible with the action of the Ptolemy groupoid on the respective coordinates.

The vector space  $\mathcal{L}_\tau$  is defined as the space of square integrable functions with finite dimensional support on  $\mathcal{A}$  with respect to the  $\alpha_\tau$  coordinates i.e. the functions  $f : \mathbb{R}^{E(\tau)} \rightarrow \mathbb{C}$ , with support contained in some  $R^F \times \{0\} \subset \mathbb{R}^{E(\tau)}$ , for some finite subset  $F \subset E(\tau)$ . The coordinates on  $\mathbb{R}^{E(\tau)}$  are the  $a_e, e \in E(\tau)$ . The function  $f$  is square integrable if

$$\int_{\mathbb{R}^F} |f|^2 \bigwedge_{e \in F} da_e < \infty$$

for any such  $F$  as above. Let  $f, g \in \mathcal{L}_\tau$ . Then let  $\mathbb{R}^F \times \{0\}$  contain the intersection of their supports. Choose  $F$  minimal with this property. Then the scalar product

$$\langle f, g \rangle = \int_{\mathbb{R}^F} f(a) \overline{g(a)} \bigwedge_{e \in F} da_e$$

makes  $\mathcal{L}_\tau$  a Hilbert space.

To define the intertwining operator  $\mathbf{K}$  we set now:

$$G_e((a_s)_{s \in F}) = \int \exp \left( \int_{\Omega} \frac{\exp(it \sum_{s \in F} \varepsilon(\tau)_{es} a_s) \sin(tc)}{2i \operatorname{sh}(\pi t) \operatorname{sh}(\pi ht)} \frac{dt}{t} + \frac{c}{\pi i h} \left( \sum_{s; \varepsilon(\tau)_{es} < 0} \varepsilon(\tau)_{es} a_s + a_e \right) \right) dc.$$

The key ingredient in the construction of this function is the *quantum dilogarithm* (going back to Barnes ([7]) and used by Baxter ([8]) and Faddeev ([37])):

$$\Phi^h(z) = \exp \left( -\frac{1}{4} \int_{\Omega} \frac{\exp(-itz)}{\operatorname{sh}(\pi t) \operatorname{sh}(\pi ht)} \frac{dt}{t} \right)$$

where the contour  $\Omega$  goes along the real axes from  $-\infty$  to  $\infty$  bypassing the origin from above.

Some properties of the quantum dilogarithm are collected below:

$$2\pi i h d \log \Phi^h(z) = \phi^h(z), \quad \lim_{\Re z \rightarrow -\infty} \Phi^h(z) = 1$$

$$\lim_{h \rightarrow 0} \Phi^h(z) / \exp(-\operatorname{Li}_2(-\exp(z))) = 2\pi i h, \quad \text{where } \operatorname{Li}_2(z) = \int_0^z \log(1-t) dt$$

$$\Phi^h(z) \Phi^h(-z) = \exp \left( \frac{z^2}{4\pi i h} \right) \exp \left( -\frac{\pi i}{12} (h + h^{-1}) \right)$$

$$\overline{\Phi^h(z)} = (\Phi^h(\bar{z}))^{-1}, \quad \Phi^h(z) = \Phi^{1/h}\left(\frac{z}{h}\right).$$

Now let  $f \in \mathcal{L}_\tau$ , namely  $f : \mathbb{R}^F \times \{0\} \rightarrow \mathbb{C}$ . Let  $(\tau, \tau')$  be the flip  $F_e$  on the edge  $e$ . Let  $a_s, s \in F$  be the coordinates in  $\mathbb{R}^F$ . If  $e \notin F$  then we set

$$\mathbf{K}_{(\tau, \tau')} = 1.$$

If  $e \in F$  then the coordinates associated to  $\tau'$  are  $a_s, s \neq e$  and  $a'_e$ . Set then

$$(\mathbf{K}_{(\tau, \tau')}f)(a_{s, s \in F, s \neq e}, a'_e) = \int G_e((a_s)_{s \in F, s \neq e}, a_e + a'_e) f((a_s)_{s \in F}) da_s.$$

The last piece of data is *the representation of the Heisenberg algebra  $H_\tau^h$*  in the Hilbert space  $\mathcal{L}_\tau$ . We can actually do better, namely enhance the space with a bimodule structure. Set

$$\rho_\tau^-(x_s) = -\pi i h \frac{\partial}{\partial a_s} + \sum_t \varepsilon(\tau)_{st} a_t$$

and

$$\rho_\tau^+(x_s) = \pi i h \frac{\partial}{\partial a_s} + \sum_t \varepsilon(\tau)_{st} a_t.$$

Then  $\rho_\tau^-$  gives a left module and  $\rho_\tau^+$  a right module structure on  $\mathcal{L}_\tau$  and the two actions commute. We have then:

**Proposition 6.2** ([27, 46, 45]). *The data  $(\mathcal{L}_\tau, \rho_\tau^\pm, \mathbf{K}_{(\tau, \tau')})$  is a projective  $*$ -representation of the quantized universal Teichmüller space.*

The data  $(\mathcal{L}_\tau, \rho_\tau^\pm, \mathbf{K}_{(\tau, \tau')})$  is called the dilogarithmic representation of the Ptolemy groupoid. The proof of this result is given in [45] and a particular case is explained with lots of details in [65].

The last step in our construction is to observe that a representation of the Ptolemy groupoid  $Pt$  induces a representation of the Ptolemy-Thompson group  $T$  by means of an identification of the Hilbert spaces  $\mathcal{L}_\tau$  for all  $\tau$ .

Projective representations are equivalent to representations of central extensions by means of the following well-known procedure. To a general group  $G$ , Hilbert space  $V$  and homomorphism  $A : G \rightarrow \text{PGL}(V)$  we can associate a central extension  $\tilde{G}$  of  $G$  by  $\mathbb{C}^*$  which resolves the projective representation  $A$  to a linear representation  $\tilde{A} : \tilde{G} \rightarrow \text{GL}(V)$ . The extension  $\tilde{G}$  is the pull-back on  $G$  of the canonical central  $\mathbb{C}^*$ -extension  $\text{GL}(V) \rightarrow \text{PGL}(V)$ .

However the central extension which we consider here is a subgroup of the  $\mathbb{C}^*$ -extension defined above, obtained by using a particular section over  $G$ . Let us write  $G = F/R$  as the quotient of the free group  $F$  by the normal subgroup

$R$  generated by the relations. Then our data consists in a homomorphism  $\bar{A} : F \rightarrow \mathrm{GL}(V)$  with the property that  $\bar{A}(r) \in \mathbb{C}^*$ , for each relation  $r \in R$ , so that  $\bar{A}$  induces  $A : G \rightarrow \mathrm{PGL}(V)$ . This data will be called *an almost-linear representation*, in order to distinguish it from a projective representation of  $G$ .

The *central extension*  $\widehat{G}$  of  $G$  associated to  $\bar{A}$  is  $\widehat{G} = F/(\ker \bar{A} \cap R)$ , namely the smallest central extension of  $S$  resolving the projective representation  $A$  to a linear representation compatible with  $\bar{A}$ . Then  $\widehat{G}$  is a central extension of  $G$  by the subgroup  $\bar{A}(R) \subset \mathbb{C}^*$  and hence it is naturally a subgroup of  $\widehat{G}$ . In other terms  $\bar{A}$  determines a projective representation  $A$  and a section over  $G$  whose associated 2-cocycle takes values in  $\bar{A}(R)$  and which describes the central extension  $\widehat{G}$ .

Now, the intertwiner functor  $\mathbf{K}$  is actually an almost-linear representation (in the obvious sense) of the Ptolemy groupoid and thus induces an almost-linear representation of the Ptolemy-Thompson group  $T$  into the unitary group. We can extract from [45] the following results (see also the equivalent construction at the level of Heisenberg algebras in [3]):

**Proposition 6.3.** *The dilogarithmic almost-linear representation  $\mathbf{K}$  has the following properties:*

- (1) *images of disjoint flips in  $\widehat{T}$  commute with each other;*
- (2) *the square of a flip is the identity;*
- (3) *the composition of the lifts of the five flips from the pentagon relation below is  $\exp(2\pi i h)$  times the identity.*

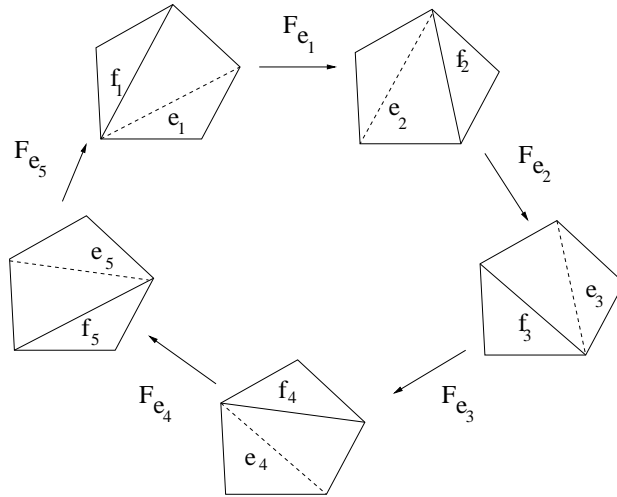

*Proof.* The first condition is that images by  $K$  of flips on disjoint edges should commute. This is obvious by the explicit formula for  $K$ . The second and third conditions are proved in [45].  $\square$

*Remark 6.4.* In [55] we considered the action of labelled flips in the pentagon relation. The composition of labelled flips is then the transposition of the labels of the two diagonals (see Proposition 3.4).

Therefore the image by  $\mathbf{K}$  of relations of the Ptolemy groupoid into  $\mathbb{C}^*$  is the subgroup  $U$  generated by  $\exp(2\pi ih)$ . We can view the pentagon relation in the Ptolemy-Thompson group  $T$  as a pentagon relation in the Ptolemy groupoid  $Pt$ . Thus the image by  $\mathbf{K}$  of relations of the Ptolemy-Thompson group  $T$  into  $\mathbb{C}^*$  is also the subgroup  $U$ . In particular the associated 2-cocycle takes values in  $U$ . If  $h$  is a formal parameter or an irrational real number we obtain then a 2-cocycle with values in  $\mathbb{Z}$ .

**Definition 6.3.** The dilogarithmic central extension  $\widehat{T}$  is the central extension of  $T$  by  $\mathbb{Z}$  associated to the dilogarithmic almost-linear representation  $\mathbf{K}$  of  $T$ , or equivalently, to the previous 2-cocycle.

### 6.3 The relative abelianization of the braided Ptolemy-Thompson group $T^*$

Recall from [51, 53] (see also 5.1) that there exists a natural surjective homomorphism  $T^* \rightarrow T$  which is obtained by *forgetting the punctures* once these groups are considered as mapping class groups. Its kernel is the infinite braid group  $B_\infty$  consisting of those braids in the punctures of  $D^*$  that move non-trivially only finitely many punctures. In other words  $B_\infty$  is the direct limit of an ascending sequence of braid groups associated to an exhaustion of  $D^*$  by punctured disks. This yields the following exact sequence description of  $T^*$ :

$$1 \rightarrow B_\infty \rightarrow T^* \rightarrow T \rightarrow 1.$$

Observe that  $H_1(B_\infty) = \mathbb{Z}$ . Thus, the abelianization homomorphism  $B_\infty \rightarrow H_1(B_\infty) = \mathbb{Z}$  induces a central extension  $T_{\text{ab}}^*$  of  $T$ , where one replaces  $B_\infty$  by its abelianization  $H_1(B_\infty)$ , as in the diagram below:

$$\begin{array}{ccccccc} 1 & \rightarrow & B_\infty & \rightarrow & T^* & \rightarrow & T & \rightarrow & 1 \\ & & \downarrow & & \downarrow & & \parallel & & \\ 1 & \rightarrow & \mathbb{Z} & \rightarrow & T_{\text{ab}}^* & \rightarrow & T & \rightarrow & 1 \end{array}$$

Then  $T_{\text{ab}}^*$  is the relative abelianization of  $T^*$  over  $T$ . We are not only able to make computations in the mapping class group  $T^*$  and thus in  $T_{\text{ab}}^*$ , but also to interpret the algebraic relations in  $T_{\text{ab}}^*$  in geometric terms.

**Proposition 6.5.** *The group  $T_{ab}^*$  has the presentation with three generators  $\alpha_{ab}^*$ ,  $\beta_{ab}^*$  and  $z$  and the relations*

$$\alpha_{ab}^{*4} = \beta_{ab}^{*3} = 1, (\beta_{ab}^* \alpha_{ab}^*)^5 = z, [\alpha_{ab}^*, z] = 1, [\beta_{ab}^*, z] = 1$$

$$[\beta_{ab}^* \alpha_{ab}^* \beta_{ab}^*, \alpha_{ab}^{*2} \beta_{ab}^* \alpha_{ab}^* \beta_{ab}^* \alpha_{ab}^{*2}] = 1$$

$$[\beta_{ab}^* \alpha_{ab}^* \beta_{ab}^*, \alpha_{ab}^{*2} \beta_{ab}^{*2} \alpha_{ab}^{*2} \beta_{ab}^* \alpha_{ab}^* \beta_{ab}^* \alpha_{ab}^{*2} \beta_{ab}^* \alpha_{ab}^{*2}] = 1$$

Moreover the projection map  $T_{ab}^* \rightarrow T$  sends  $\alpha_{ab}^*$  to  $\alpha$ ,  $\beta_{ab}^*$  to  $\beta$  and  $z$  to the identity.

*Proof.* Recall from [51] that  $T^*$  is generated by the two elements  $\alpha^*$  and  $\beta^*$  below.

- The support of the element  $\beta^*$  of  $T^*$  is the central hexagon. Furthermore  $\beta^*$  acts as the counterclockwise rotation of order three which permutes cyclically the punctures. One has  $\beta^{*3} = 1$ .

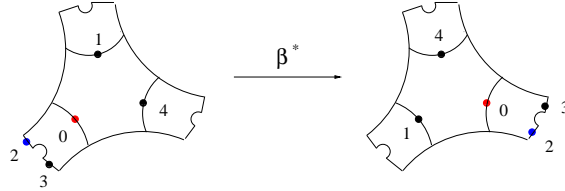

- The support of the element  $\alpha^*$  of  $T^*$  is the union of two adjacent hexagons, one of them being the support of  $\beta^*$ . Then  $\alpha^*$  rotates counterclockwise the support of angle  $\frac{\pi}{2}$ , by keeping fixed the central puncture. One has  $\alpha^{*4} = 1$ .

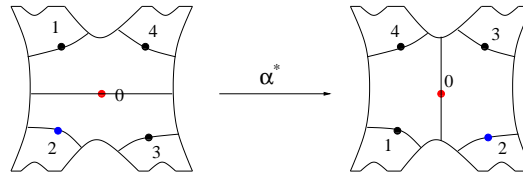

Let now  $e$  be a simple arc in  $D^*$  which connects two punctures. We associate a braiding  $\sigma_e \in B_\infty$  to  $e$  by considering the homeomorphism that moves clockwise the punctures at the endpoints of the edge  $e$  in a small neighborhood of the edge, in order to interchange their positions. This means that if  $\gamma$  is an arc transverse to  $e$ , then the braiding  $\sigma_e$  moves  $\gamma$  to the left when it approaches  $e$ . Such a braiding will be called *positive*, while  $\sigma_e^{-1}$  is *negative*.

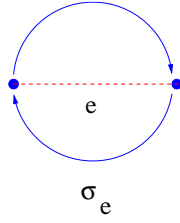

It is known that  $B_\infty$  is generated by the braids  $\sigma_e$  where  $e$  runs over the edges of the binary tree with vertices at the punctures. Let  $\iota : B_\infty \rightarrow T^*$  be the inclusion. It is proved in [51] that the braid generator  $\sigma_{[02]}$  associated to the edge joining the punctures numbered 0 and 2 has image

$$\iota(\sigma_{[02]}) = (\beta^* \alpha^*)^5$$

because we have

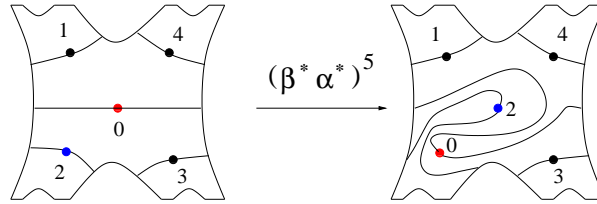

Recall next that all braid generators  $\sigma_e$  are conjugate and call  $z$  their image in  $T_{ab}^*$ . It follows that  $T_{ab}^*$  is an extension of  $T$  by  $\mathbb{Z}$ . Moreover, it is simple to check that  $\alpha^* \sigma_{[02]} \alpha^{-1}$  is also a braid generator, namely  $\sigma_{[\alpha^*(0)\alpha^*(2)]}$ . The same holds for  $\beta^* \sigma_{[02]} \beta^{*-1} = \sigma_{[\beta^*(0)\beta^*(2)]}$ . This implies that the extension  $T_{ab}^*$  is central.

In particular, a presentation of  $T_{ab}^*$  can be obtained by looking at the lifts of relations in  $T$ , together with those coming from the fact that  $z$  is central.

The first set of relations above are obviously satisfied by  $T_{ab}^*$ . Finally recall from [51] that  $T^*$  splits over the smaller Thompson group  $F$  and thus the following relations hold true in  $T^*$ :

$$[\beta^* \alpha^* \beta^*, \alpha^{*2} \beta^* \alpha^* \beta^* \alpha^{*2}] = [\beta^* \alpha^* \beta^*, \alpha^{*2} \beta^{*2} \alpha^{*2} \beta^* \alpha^* \beta^* \alpha^{*2} \beta^* \alpha^{*2}] = 1.$$

Thus relations from the second set are automatically verified in  $T_{ab}^*$ . Since these relations form a complete set of lifts of relations presenting  $T$  and since  $z$  is central, then they represent a complete system of relations in  $T_{ab}^*$ . This ends the proof.  $\square$

### 6.4 Computing the class of $T_{ab}^*$

**Lemma 6.6.** *The class  $c_{T_{ab}^*}$  is a multiple of the Euler class.*

*Proof.* Since  $T^*$  splits over the Thompson group  $F \subset T$  (see [51]) it follows that  $T_{ab}^*$  also splits over  $F$ . Therefore the extension class  $c_{T_{ab}^*}$  lies in the kernel of the restriction map  $H^2(T) \rightarrow H^2(F)$ . According to [63] the kernel is generated by the Euler class.  $\square$

Let us introduce the group  $T_{n,p,q}$  presented by the generators  $\bar{\alpha}, \bar{\beta}, z$  and the relations:

$$(\bar{\beta}\bar{\alpha})^5 = z^n$$

$$\bar{\alpha}^4 = z^p$$

$$\bar{\beta}^3 = z^q$$

$$[\bar{\beta}\bar{\alpha}\bar{\beta}, \bar{\alpha}^2\bar{\beta}\bar{\alpha}\bar{\beta}\bar{\alpha}^2] = 1$$

$$[\bar{\beta}\bar{\alpha}\bar{\beta}, \bar{\alpha}^2\bar{\beta}\bar{\alpha}^2\bar{\beta}\bar{\alpha}\bar{\beta}\bar{\alpha}^2\bar{\beta}^2\bar{\alpha}^2] = 1$$

and

$$[\bar{\alpha}, z] = [\bar{\beta}, z] = 1.$$

Recall from Proposition 6.5 that  $T_{ab}^* = T_{1,0,0}$ . It is easy to see that  $T_{n,p,q}$  are central extensions of  $T$  by  $\mathbb{Z}$ . Because of the last two commutation relations the extension  $T_{n,p,q}$  splits over the Thompson group  $F$ . Thus the restriction of  $c_{T_{n,p,q}}$  to  $F$  vanishes and a fortiori the restriction to the commutator subgroup  $F' \subset F$ . According to [63] we have  $H^2(F') = \mathbb{Z}\alpha$  where  $\alpha$  is the discrete Godbillon-Vey class. Thus the map  $H^2(T) \rightarrow H^2(F')$  is the projection  $\mathbb{Z}\alpha \oplus \mathbb{Z}\chi \rightarrow \mathbb{Z}\alpha$ . Since  $c_{\widehat{T}}$  belongs to the kernel of  $H^2(T) \rightarrow H^2(F')$  we derive that  $c_{T_{n,p,q}} \in \mathbb{Z}\chi$ . Set  $c_{T_{n,p,q}} = \chi(n, p, q)\chi$ .

**Proposition 6.7** ([55]). *We have  $\chi(n, p, q) = 12n - 15p - 20q$ .*

**Corollary 6.8.** *We have  $c_{T_{ab}^*} = 12\chi$ .*

*Remark 6.9.* The extension  $T^* \rightarrow T$  splits also over the subgroup  $\langle \alpha^2, \beta \rangle$  which is isomorphic to  $\mathrm{PSL}(2, \mathbb{Z})$  (see [51]). This implies that  $c_{T_{ab}^*}$  is a multiple of  $6\chi$ .

*Remark 6.10.* The following refinement of the above argument shows that  $c_{T_{ab}^*}$  is a multiple of  $12\chi$ . Consider the element  $\gamma = \alpha\beta\alpha\beta\alpha^2\beta\alpha\beta\alpha^2$  in  $T$ . Then  $\gamma^3 = \alpha^2$  so that  $\gamma^6 = \alpha^4 = 1$ . Let then  $\gamma_{ab}^* = \alpha_{ab}^*\beta_{ab}^*\alpha_{ab}^*\beta_{ab}^*\alpha_{ab}^{*2}\beta_{ab}^*\alpha_{ab}^*\beta_{ab}^*\alpha_{ab}^{*2}$

be a lift of  $\gamma$  to  $T_{ab}^*$ . One can show that  $(z^{-1}\gamma_{ab}^*)^3 = \alpha_{ab}^{*2}$ . The elements  $\gamma$  and  $\alpha$  of orders 6 and 4 respectively determine an embedding of  $\mathbb{Z}/6\mathbb{Z} *_{\mathbb{Z}/2\mathbb{Z}} \mathbb{Z}/4\mathbb{Z}$  into  $T$ . The relation from above shows that one can lift this embedding to an embedding of  $\mathbb{Z}/6\mathbb{Z} *_{\mathbb{Z}/2\mathbb{Z}} \mathbb{Z}/4\mathbb{Z}$  into  $T_{ab}^*$  by using the lifts  $z^{-1}\gamma_{ab}^*$  and  $\alpha_{ab}^*$ . Now we know that  $\mathbb{Z}/6\mathbb{Z} *_{\mathbb{Z}/2\mathbb{Z}} \mathbb{Z}/4\mathbb{Z}$  is isomorphic to  $\mathrm{SL}(2, \mathbb{Z})$  and  $H^2(\mathrm{SL}(2, \mathbb{Z}), \mathbb{Z}) = \mathbb{Z}/12\mathbb{Z}$ . Moreover the pull-back of the Euler class on  $\mathrm{SL}(2, \mathbb{Z}) \subset T \subset \mathrm{Homeo}^+(S^1)$  is the generator of  $\mathbb{Z}/12\mathbb{Z}$ . This implies that  $c_{T_{ab}^*}$  is a multiple of  $12\chi$ .

## 6.5 Identifying the two central extensions of $T$

The main result of this section is the following:

**Proposition 6.11.** *The dilogarithmic extension  $\widehat{T}$  is identified to  $T_{ab}^*$ .*

*Proof.* The main step is to translate the properties of the dilogarithmic representation of the Ptolemy groupoid in terms of the Ptolemy-Thompson group. Since  $\widehat{T}$  is a central extension of  $T$  it is generated by the lifts  $\widehat{\alpha}, \widehat{\beta}$  of  $\alpha$  and  $\beta$  together with the generator  $z$  of the center. Let us see what are the relations arising in the group  $\widehat{T}$ . According to Proposition 6.3 lifts of disjoint flips should commute. By a simple computation we can show that the elements  $\beta\alpha\beta$ ,  $\alpha^2\beta\alpha\beta\alpha^2$  and  $\alpha^2\beta\alpha^2\beta\alpha\beta\alpha^2\beta^2\alpha^2$  act as disjoint flips on the Farey triangulation. In particular we have the relations

$$[\widehat{\beta}\widehat{\alpha}\widehat{\beta}, \widehat{\alpha}^2\widehat{\beta}\widehat{\alpha}\widehat{\beta}\widehat{\alpha}^2] = [\widehat{\beta}\widehat{\alpha}\widehat{\beta}, \widehat{\alpha}^2\widehat{\beta}\widehat{\alpha}^2\widehat{\beta}\widehat{\alpha}\widehat{\beta}\widehat{\alpha}^2\widehat{\beta}^2\widehat{\alpha}^2] = 1$$

satisfied in  $\widehat{T}$ . Moreover, by construction we also have

$$\widehat{\beta}^3 = \widehat{\alpha}^4 = 1$$

meaning that the  $\widehat{\alpha}$  is still periodic of order 4 while  $\widehat{\beta}$  is not deformed.

Eventually the only non-trivial lift of relations comes from the pentagon relation  $(\widehat{\beta}\widehat{\alpha})^5$ . The element  $(\widehat{\beta}\widehat{\alpha})^5$  is actually the permutation of the two edges in the pentagon times the composition of the five flips. The pentagon equation is not anymore satisfied but Proposition 6.3 shows that the dilogarithmic image of  $(\widehat{\beta}\widehat{\alpha})^5$  is a scalar operator. Since  $z$  is the generator of the kernel  $\mathbb{Z}$  of  $\widehat{T} \rightarrow T$  it follows that the lift of the pentagon equation from  $T$  to  $\widehat{T}$  is given by

$$(\widehat{\beta}\widehat{\alpha})^5 = z.$$

According to Proposition 6.5 all relations presenting  $T_{ab}^*$  are satisfied in  $\widehat{T}$ . Since  $\widehat{T}$  is a nontrivial central extension of  $T$  by  $\mathbb{Z}$  it follows that the groups are isomorphic.  $\square$

*Remark 6.12.* The key point in the above proof is that all pentagon relations in  $Pt$  are transformed in a single pentagon relation in  $T$  and thus the scalars associated to the pentagons in  $Pt$  should be the same.

*Remark 6.13.* The dilogarithmic representation of  $T$  induces a projective representation of the smaller Thompson group  $F \subset T$ . The latter is equivalent to a linear representation since the braided Ptolemy-Thompson group splits over  $F$ . It is presently unknown whether the dilogarithmic representation can be extended to one of the groups  $V$  or  $\mathcal{B}$ .

## 6.6 Classification of central extensions of the group $T$

Our main concern here is to identify the cohomology classes of all central extensions of  $T$  in  $H^2(T)$ . Before doing that we consider a series of central extensions  $T_{n,p,q,r,s}$  of  $T$  by  $\mathbb{Z}$ , having properties similar to those of  $\widehat{T}$ .

**Definition 6.4.** The group  $T_{n,p,q,r,s}$ , is presented by the generators  $\bar{\alpha}, \bar{\beta}, z$  and the relations:

$$(\bar{\beta}\bar{\alpha})^5 = z^n$$

$$\bar{\alpha}^4 = z^p$$

$$\bar{\beta}^3 = z^q$$

$$[\bar{\beta}\bar{\alpha}\bar{\beta}, \bar{\alpha}^2\bar{\beta}\bar{\alpha}\bar{\beta}\bar{\alpha}^2] = z^r$$

$$[\bar{\beta}\bar{\alpha}\bar{\beta}, \bar{\alpha}^2\bar{\beta}\bar{\alpha}^2\bar{\beta}\bar{\alpha}\bar{\beta}\bar{\alpha}^2\bar{\beta}^2\bar{\alpha}^2] = z^s$$

$$[\bar{\alpha}, z] = [\bar{\beta}, z] = 1.$$

Let us denote  $T_{n,p,q,r} = T_{n,p,q,r,0}$  and  $T_{n,p,q} = T_{n,p,q,0,0}$ .

According to [51] we can identify  $\widehat{T}$  with  $T_{1,0,0}$ . In fact the group  $T^*$  is split over the smaller Thompson group  $F \subset T$  and thus  $\widehat{T}$  is split over  $F$ . Furthermore  $F$  is generated by the elements  $\beta^2\alpha$  and  $\beta\alpha^2$  and thus relations of  $F$  are precisely given by the above commutation relations. Thus the last two relations hold, while  $z$  is central and thus  $\widehat{T}$  is given by the above presentation.

*Remark 6.14.* We considered in [51] the twin group  $T^\sharp$  and gave a presentation of it. Then, using a similar procedure there is a group obtained from  $T^\sharp$  by abelianizing the kernel  $B_\infty$ , which is identified to  $T_{3,1,0}$ .

**Theorem 6.15** ([55]). *Every central extension of  $T$  by  $\mathbb{Z}$  is of the form  $T_{n,p,q,r}$ . Moreover, the class  $c_{T_{n,p,q,r}} \in H^2(T)$  of the extension  $T_{n,p,q,r}$  is given by:*

$$c_{T_{n,p,q,r}} = (12n - 15p - 20q - 60r)\chi + r\alpha.$$

*Moreover the central  $T_{n,p,q}$  are precisely those central extensions whose restrictions on  $F \subset T$  splits.*

## 7 More asymptotically rigid mapping class groups

### 7.1 Other planar surfaces and braided Houghton groups

The aim of this section is to use the previous methods in order to recover the braided Houghton groups as mapping class groups of surfaces of infinite type. In particular the braid group on infinitely many strands is realized as the commutator subgroup of an explicit finitely presented group. This has been done previously by Dynnikov who used the so-called three pages representations of braids and links in ([35]). Our groups are slightly different from those considered by Dynnikov and their presentation is of a different nature, because it comes from a geometric description in terms of mapping classes. Moreover, we obtain that the word problem of the braided Houghton groups is solvable. A version of our construction was used by Degenhardt, who introduced the braided Houghton groups  $BH_n$  in his (unpublished) thesis [31]. Then Kai-Uwe Bux described a conjectural approach to the finiteness properties of these groups in [23].

In order to define the mapping class group of a surface of infinite type we need to fix the behavior of homeomorphisms at infinity. The main ingredient used in [51] consists of adjoining rigid structures, as defined below in a slightly more general context:

**Definition 7.1.** *A rigid structure  $d$  on the surface  $\Sigma$  is a decomposition of  $\Sigma$  into 2-disks with disjoint interiors, called elementary pieces. We suppose that the closures of the elementary pieces are still 2-disks.*

We assume that we are given a family  $F$  of compact subsurfaces of  $\Sigma$  such that each member of  $F$  is a finite union of elementary pieces, and called the family of admissible subsurfaces of  $\Sigma$ .

To the data  $(\Sigma, d, F)$  we can associate an asymptotically rigid mapping class group  $\mathcal{M}(\Sigma, d, F)$  as follows. We first restrict to those homeomorphisms that act in the simplest possible way at infinity.

**Definition 7.2.** A homeomorphism  $\varphi$  between two surfaces endowed with rigid structures is *rigid* if it sends the rigid structure of one surface onto the rigid structure of the other.

The homeomorphism  $\varphi : \Sigma \rightarrow \Sigma$  is said to be *asymptotically rigid* if there exists some admissible subsurface  $C \subset \Sigma$ , called a support for  $\varphi$ , such that  $\varphi(C) \subset \Sigma$  is also an admissible subsurface of  $\Sigma$  and the restriction  $\varphi|_{\Sigma-C} : \Sigma - C \rightarrow \Sigma - \varphi(C)$  is rigid.

As it is customary when studying mapping class groups we now consider isotopy classes of such homeomorphisms.

**Definition 7.3.** The group  $\mathcal{M}(\Sigma, d, F)$  of isotopy classes of asymptotically rigid homeomorphisms is called the *asymptotically rigid mapping class group* of  $\Sigma$  corresponding to the rigid structure  $d$  and family of admissible subsurfaces  $F$ .

*Remark 7.1.* Two asymptotically rigid homeomorphisms that are isotopic are isotopic among asymptotically rigid homeomorphisms.

The ribbon tree  $D$  and punctured ribbon trees  $D^*$  and  $D^\#$  are particular examples of surfaces of infinite type with rigid structures. We want to turn to even simpler examples obtained from thickening trees in the plane and show that interesting groups could be obtained in this way. Consider the planar ribbon  $Y_n$ , which is a 2-dimensional neighborhood of the wedge of  $n$  half-lines (or rays) in the plane that intersect at the origin. Assume that every half-line is endowed with a linear coordinates system in which the origin corresponds to 0 and that the rotation of order  $n$  sends them isometrically one into the other.

Let  $Y_n^*$  (respectively  $Y_n^\#$ ) be the punctured ribbon obtained from  $Y_n$  by puncturing it along the set of points of positive (respectively nonnegative) integer coordinates on each half-line. Punctures are therefore identified with nonnegative integers along each ray. The origin has coordinates 0 on all half-lines and does appear only in  $Y_n^\#$ .

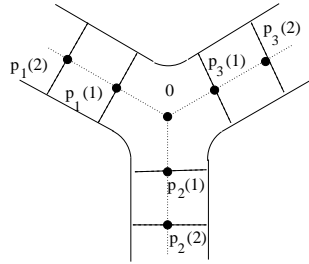

There is a family of parallel arcs associated to each ray, obtained by drawing a properly embedded segment orthogonal to the respective half-line and passing through the puncture labelled  $n$ , for every  $n \in \mathbb{Z}_+ - \{0\}$ .

The surface  $Y_n$  (respectively  $Y_n^*$ ,  $Y_n^\sharp$ ) is then divided by these arcs into elementary pieces, which are of two types: one central (respectively punctured for  $Y_n^*$ )  $2n$ -gon containing the origin and infinitely many (respectively punctured) squares which sit along the half-lines. One defines the admissible subsurfaces of  $Y_n$  (respectively  $Y_n^*$ ,  $Y_n^\sharp$ ) to be those (punctured)  $2n$ -gons which contain the (punctured) central  $2n$ -gon and are made of finitely many elementary pieces.

Let  $\mathcal{M}(Y_n)$  (respectively  $\mathcal{M}(Y_n^*)$ ,  $\mathcal{M}(Y_n^\sharp)$ ) denote the asymptotically rigid mapping class group of  $Y_n$  (respectively  $Y_n^*$ ,  $Y_n^\sharp$ ) with the above rigid structure. We also suppose that each element  $\varphi$  of  $\mathcal{M}(Y_n)$  (respectively  $\mathcal{M}(Y_n^*)$ ,  $\mathcal{M}(Y_n^\sharp)$ ) is associated with pairs of admissible subsurfaces  $C$  and  $\varphi(C)$  containing *the same number* of punctures. This additional condition was automatically verified by pairs of admissible subsurfaces of the ribbon tree  $D^*$  with homeomorphic complements.

The group  $\mathcal{M}(Y_n)$  has a particularly simple form. In fact any element of  $\mathcal{M}(Y_n)$  corresponds to a triple  $((P, Q), r)$ , where  $P$  and  $Q$  are admissible  $2n$ -gons and  $r$  is an order  $n$  rotation that gives the recipe for identifying the boundary arcs of  $P$  and  $Q$ . Moreover, an admissible  $2n$ -gon  $P \subset Y_n$  is completely determined by the vector  $v_P \in (\mathbb{Z}_+ - \{0\})^n$  recording the coordinates of those punctures that lie on the boundary arcs of  $P$ , one coordinate for each ray. The cyclic group of rotations  $\mathbb{Z}/n\mathbb{Z}$  acts on  $\mathbb{Z}^n$  by permuting the coordinates and preserves the subgroup  $\mathbb{Z}^{n-1} \subset \mathbb{Z}^n$  of the vectors having the sum of their coordinates zero. The map that sends the pair  $((P, Q), r)$  into  $(v_Q - r(v_P), r) \in \mathbb{Z}^n \rtimes \mathbb{Z}/n\mathbb{Z}$  induces an isomorphism of  $\mathcal{M}(Y_n)$  onto the subgroup  $\mathbb{Z}^{n-1} \rtimes \mathbb{Z}/n\mathbb{Z}$ .

One expects  $\mathcal{M}(Y_n^*)$  and  $\mathcal{M}(Y_n^\sharp)$  to be extensions of  $\mathcal{M}(Y_n)$  by an infinite braid group  $B_\infty$ . If  $\mathcal{M}(Y_n)$  were abelian then the infinite braid group  $B_\infty$  would be the commutator subgroup of the extension group. However the semi-direct product  $\mathbb{Z}^{n-1} \rtimes \mathbb{Z}/n\mathbb{Z}$  is not direct for  $n \geq 3$ , and hence it is convenient to restrict to those mapping classes in the above groups coming from end preserving homeomorphisms.

Consider therefore the subgroups  $\mathcal{M}_\partial(Y_n)$  (respectively  $\mathcal{M}_\partial(Y_n^*)$ ,  $\mathcal{M}_\partial(Y_n^\sharp)$ ) generated by those homeomorphisms which are end preserving i.e. inducing a trivial automorphism of the ends of  $Y_n$ . Alternatively, the homeomorphisms should send each ray into itself, at least outside a large enough compact set.

It follows from above that  $\mathcal{M}_\partial(Y_n)$  is isomorphic to  $\mathbb{Z}^{n-1}$ .

The groups  $\mathcal{M}_\partial(Y_n^*)$  are isomorphic to the braided Houghton groups considered by Degenhardt ([31]) and Dynnikov ([35]). It is known that these are

finitely presented groups for all  $n \geq 3$ . The same result holds for the larger related groups  $\mathcal{M}_\partial(Y_n^\sharp)$ , as it is proved in [48]:

**Theorem 7.2.** ([48]) *The groups  $\mathcal{M}(Y_n^\sharp)$  and  $\mathcal{M}_\partial(Y_n^\sharp)$  are finitely presented for  $n \geq 3$ . The commutator subgroup of  $\mathcal{M}_\partial(Y_n^\sharp)$  is the infinite braid group  $B_\infty$  in the punctures of  $Y_n^\sharp$ . Moreover, the groups  $\mathcal{M}_\partial(Y_n^\sharp)$  (and their versions) have solvable word problem.*

*Proof.* Let us outline the proof. First, we can express these groups as extensions by the infinite braid group, by means of the following exact sequence:

$$1 \rightarrow B_\infty \rightarrow \mathcal{M}_\partial(Y_n^\sharp) \rightarrow \mathbb{Z}^{n-1} \rightarrow 1$$

where  $B_\infty = \lim_{k \rightarrow \infty} B_{kn+1}$  is the limit of the braid groups of an exhausting sequence of admissible subsurfaces of  $Y_n^\sharp$ . In fact, a mapping class  $\varphi \in \mathcal{M}_\partial(Y_n^\sharp)$  sends a support  $2n$ -gon into another support  $2n$ -gon, by translating the arc on the half-line  $l_j$  of  $k_j$  units towards the center. Since the support hexagons should contain the same number of punctures we have  $k_1 + k_2 + \dots + k_n = 0$ . The map sending  $\varphi$  to  $(k_1, k_2, \dots, k_n)$  is a surjection onto  $\mathbb{Z}^{n-1}$ . The claim follows.

Let the line  $l_j$  be punctured along the points  $p_j(i)$  at distance  $i$  from the origin. Consider the mapping class of the homeomorphism  $d_j$  which translates all punctures of the line  $l_j \cup l_{j+1}$  one unit in the counterclockwise direction, as in the figure below:

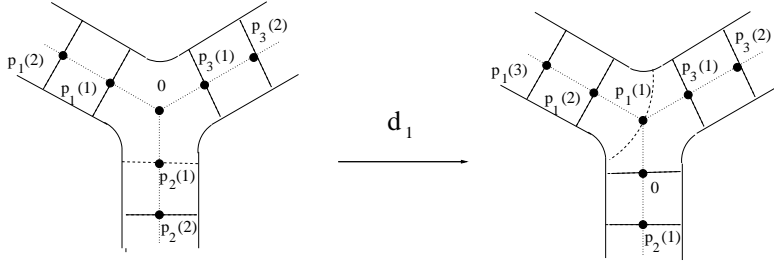

We use the convention that the groups act on the right: thus the composition  $ab$  denotes  $a$  followed by  $b$ . Moreover, the set of subscripts corresponding to the rays is  $\{1, 2, \dots, n\}$ , which is naturally identified to  $\mathbb{Z}/n\mathbb{Z}$ ; let then  $<$  denote the cyclic order on  $\mathbb{Z}/n\mathbb{Z}$ . An explicit presentation is then provided in [48]:

**Proposition 7.3** ([48]). *Set  $u_i = d_i d_{i+1} d_i^{-1} d_{i+1}^{-1}$ . Then the group  $\mathcal{M}_\partial(Y_n^\sharp)$  is generated by the  $d_1, d_2, \dots, d_n$  and admits the presentation:*

$$d_n d_{n-1} d_{n-2} \cdots d_1 = 1$$

$$u_{i_1} u_{i_2} u_{i_3} u_{i_1} = u_{i_2} u_{i_3} u_{i_1} u_{i_2} = u_{i_3} u_{i_1} u_{i_2} u_{i_3}, \text{ if } i_1 < i_2 < i_3$$

$$d_{i-1}^{-1} u_i d_{i-1} = d_i u_i d_i^{-1} \text{ for all } i$$

$$u_i u_j u_i = u_j u_i u_j, \text{ for all } i, j$$

$$d_{i-1}^{-1} u_i d_{i-1} u_i d_{i-1}^{-1} u_i d_{i-1} = u_i d_{i-1}^{-1} u_i d_{i-1} u_i, \text{ for all } i$$

$$[d_i u_i d_i^{-1}, u_j] = 1, \text{ for all } i \neq j$$

$$[d_i u_i d_i^{-1}, d_j] = 1, \text{ for all } i < j < i - 1$$

$$d_j u_i d_j^{-1} = u_i u_j u_j^{-1}, \text{ for all } i < j < i - 1.$$

Finally the group  $\mathcal{M}_\partial(Y_n^\sharp)$  (and its versions) has solvable word problem. In fact, for any word  $w$  in the generators  $d_i$  there exists a support of  $w$  made of elementary pieces not farther than  $|w| + 1$  units apart from the central  $2n$ -gon. Then the proof given in [51] can be adapted to our situation. Observe that we actually use the fact that the word problem is solvable in braid groups.  $\square$

*Remark 7.4.* Let  $S_\infty$  denote the infinite permutation group of punctures of  $Y_n^*$  obtained as the direct limit of finite permutation groups of punctures in an ascending sequence of admissible subsurfaces.

The Houghton groups  $H_n$  considered by Brown ([18]) are quotients of  $\mathcal{M}_\partial(Y_n^*)$  induced from the obvious homomorphism  $B_\infty \rightarrow S_\infty$  sending braids into the associated permutations. This means that we have natural exact sequences

$$\begin{array}{ccccccc} 1 & \rightarrow & B_\infty & \rightarrow & \mathcal{M}_\partial(Y_n^\sharp) & \rightarrow & \mathbb{Z}^{n-1} \rightarrow 1 \\ & & \downarrow & & \downarrow & & \downarrow \\ 1 & \rightarrow & S_\infty & \rightarrow & H_n & \rightarrow & \mathbb{Z}^{n-1} \rightarrow 1 \end{array}$$

*Remark 7.5.* The group  $\mathcal{M}_\partial(Y_2^\sharp)$  (and its variants) is generated by two elements, namely  $d = d_1 = d_2^{-1}$  and  $u_1 = \sigma_{0p_1(1)}$ . However,  $\mathcal{M}_\partial(Y_2^\sharp)$  is not finitely presented since the commutativity relations coming from the braid group are independent, namely we have infinitely many relations of the form  $[d^k u d^{-k}, d^m u d^{-m}] = 1$ , for all integers  $m, k$  with  $|m - k| \geq 1$ . Also  $\mathcal{M}_\partial(Y_2^\sharp)$  surjects onto the Houghton group  $H_2$  which is known to be infinitely presented. In some sense  $\mathcal{M}_\partial(Y_2^\sharp)$  is similar to the lamplighter groups.

*Remark 7.6.* Since all generators of  $B_\infty$  are conjugate the abelianization of  $B_\infty$  is  $\mathbb{Z}$ . The abelianization homomorphism  $B_\infty \rightarrow \mathbb{Z}$  induces an extension  $\mathcal{M}_\partial(Y_n^\sharp)^{ab}$  as follows:

$$\begin{array}{ccccccc}
1 & \rightarrow & B_\infty & \rightarrow & \mathcal{M}_\partial(Y_n^*) & \rightarrow & \mathbb{Z}^{n-1} \rightarrow 1 \\
& & \downarrow & & \downarrow & & \downarrow \\
1 & \rightarrow & \mathbb{Z} & \rightarrow & \mathcal{M}_\partial(Y_n^*)^{ab} & \rightarrow & \mathbb{Z}^{n-1} \rightarrow 1
\end{array}$$

For  $n = 2$  it follows that  $\mathcal{M}_\partial(Y_2^*)^{ab}$  is abelian, generated by the images of  $d$  and  $u$ . In particular, we obtain that  $\mathcal{M}_\partial(Y_2^*)^{ab} \cong H_1(\mathcal{M}_\partial(Y_2^*)) = \mathbb{Z}^2$ .

For  $n \geq 3$  the group  $\mathcal{M}_\partial(Y_n^*)^{ab}$  is a nontrivial (non-abelian) extension of  $\mathbb{Z}^{n-1}$  by  $\mathbb{Z}$ .

*Remark 7.7.* Given three rays in the binary tree we can associate an embedding of  $Y_3^*$  into  $D^*$  that induces injective compatible homomorphisms  $\mathbb{Z}^2 \rtimes \mathbb{Z}/3\mathbb{Z} \rightarrow T$  and  $\mathcal{M}(Y_3^*) \rightarrow T^*$ .

## 7.2 Infinite genus surfaces and mapping class groups

In [50], we proved that the Teichmüller tower of groupoids in genus zero may be embodied in a very concrete group, the universal mapping class group in genus zero  $\mathcal{B}$ . Not only does  $\mathcal{B}$  contain the tower, but its remarkable property of being finitely presented also realizes, in the category of groups, the analogous property for the tower of groupoids.

We give a partial solution of the problem of realizing the higher genus Teichmüller tower in the category of groups. We construct a *finitely generated* group  $\mathcal{M}$  that contains all the pure mapping class groups  $PM(g, n)$  (with  $n > 0$ ). The solution is partial as  $\mathcal{M}$  does not contain all the (non-pure) mapping class groups  $\mathcal{M}(g, n)$ .

**Definition 7.4** (following [52]). Let  $\mathcal{T}_\infty$  be the graph obtained from the planar dyadic tree by attaching a loop on each edge, based on its middle point. The three-dimensional thickening of  $\mathcal{T}_\infty$  is a handlebody, whose boundary is an orientable surface  $\mathcal{S}_\infty$  of infinite genus.

- (1) An orientation-preserving homeomorphism  $g$  of  $\mathcal{S}_\infty$  is *asymptotically rigid* if there exist two connected subsurfaces  $S_0$  and  $S_1$  of  $\mathcal{S}_\infty$  such that  $g$  induces, by restriction on each connected component of  $\mathcal{T}_\infty \cap (\mathcal{S}_\infty \setminus S_0)$ , an isomorphism (of graphs) onto a connected component of  $\mathcal{T}_\infty \cap (\mathcal{S}_\infty \setminus S_1)$ , which respects the local orientation of the edges (coming from the planarity of the dyadic tree).
- (2) The *asymptotically rigid mapping class group of infinite genus*  $\mathcal{M}$  is the group of mapping classes of isotopies of asymptotically rigid homeomorphisms of the surface  $\mathcal{S}_\infty$ .

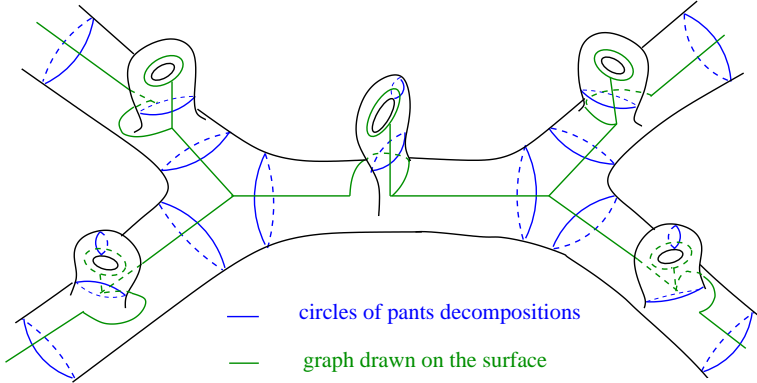

Forgetting the loops of  $\mathcal{T}_\infty$ , one obtains a morphism from  $\mathcal{M}$  to  $\text{Homeo}(\partial T)$ , whose image is Thompson's group  $V$ . It follows easily, as for  $\mathcal{B}$ , that  $\mathcal{M}$  is an extension of Thompson's group  $V$  by the pure mapping class group of the surface:

$$1 \rightarrow PM \rightarrow \mathcal{M} \rightarrow V \rightarrow 1$$

The pure mapping class group  $PM$  is countable, and generated by the Dehn twists around the closed simple curves embedded into  $\mathcal{S}_\infty$ , and is not finitely generated.

The first result of [52] is:

**Theorem 7.8** ([52] Th. 1.1). *The group  $\mathcal{M}$  is finitely generated.*

The proof is based on a convenient presentation due to S. Gervais of the mapping class groups  $PM(g, n)$  ([60]), from which we deduce that  $PM$  is generated by a set of Dehn twists around some curves of  $\mathcal{S}_\infty$  forming a certain set  $\mathcal{F}$ . By collapsing the handles of the surface  $\mathcal{S}_\infty$  onto punctures, those curves may be identified with paths on  $D^*$  – the planar surface we have introduced for  $T^*$  – joining two punctures. Exploiting the action of  $T^*$  on the homotopy classes of those paths, one shows that almost all of them are equivalent modulo  $T^*$ . It is possible to “lift” this result to  $\mathcal{S}_\infty$ , and this enables us to prove that the family  $\mathcal{F}$  is finite modulo the action of a finitely generated subgroup of  $\mathcal{M}$ . It follows easily that  $\mathcal{M}$  is generated by a finite number of Dehn twists and by the lifts to  $\mathcal{M}$  of generators of  $V$ .

Using the Lyndon-Hochschild-Serre spectral sequence associated to the short exact sequence

$$1 \rightarrow PM \rightarrow \mathcal{M} \rightarrow V \rightarrow 1$$

and a theorem of Brown asserting that the rational homology of  $V$  is trivial ([19]), we prove that the group  $\mathcal{M}$  has the same rational homology as  $PM$ .

Describing  $PM$  as a direct limit of groups  $PM(g, n)$ , it follows from Harer's stability theorem ([75]) that the homology of  $PM$  is the stable homology of the mapping class group.

**Theorem 7.9** ([52], Th. 1.2). *The rational homology of the group  $\mathcal{M}$  is isomorphic to the rational stable homology of the mapping class group.*

Our result proves, therefore, that there exists a finitely generated group whose rational homology is isomorphic to that of  $BU$ , the universal classifying space of complex fibre bundles. We compute that  $H^2(\mathcal{M}, \mathbb{Z}) = \mathbb{Z}$ , and show that the generator of this second cohomology group may be identified with the first universal Chern class.

As a corollary of the argument of the proof the group  $\mathcal{M}$  is perfect and  $H_2(\mathcal{M}, \mathbb{Z}) = \mathbb{Z}$ . For a reason that will become clear in what follows, the generator of  $H^2(\mathcal{M}, \mathbb{Z}) \cong \mathbb{Z}$  is called *the first universal Chern class* of  $\mathcal{M}$ , and is denoted  $c_1(\mathcal{M})$ .

Let  $\mathcal{M}_g$  be the mapping class group of a closed surface  $\Sigma_g$  of genus  $g$ . We show that the standard representation  $\rho_g : \mathcal{M}_g \rightarrow \mathrm{Sp}(2g, \mathbb{Z})$  in the symplectic group, deduced from the action of  $\mathcal{M}_g$  on  $H_1(\Sigma_g, \mathbb{Z})$ , extends to the infinite genus case, by replacing the finite dimensional setting by concepts of Hilbert analysis. In particular, a key role is played by Shale's *restricted symplectic group*  $\mathrm{Sp}_{\mathrm{res}}(\mathcal{H}_r)$  on the real Hilbert space  $\mathcal{H}_r$  generated by the homology classes of non-separating closed curves of  $\mathcal{S}_\infty$ . We then have:

**Theorem 7.10** ([52]). *The action of  $\mathcal{M}$  on  $H_1(\mathcal{S}_\infty, \mathbb{Z})$  induces a representation  $\rho : \mathcal{M} \rightarrow \mathrm{Sp}_{\mathrm{res}}(\mathcal{H}_r)$ .*

The generator  $c_1$  of  $H^2(\mathcal{M}_g, \mathbb{Z})$  is called the first Chern class, since it may be obtained as follows (see, e.g., [101]). The group  $\mathrm{Sp}(2g, \mathbb{Z})$  is contained in the symplectic group  $\mathrm{Sp}(2g, \mathbb{R})$ , whose maximal compact subgroup is the unitary group  $U(g)$ . Thus, the first Chern class may be viewed in  $H^2(B\mathrm{Sp}(2g, \mathbb{R}), \mathbb{Z})$ . It can be first pulled-back on  $H^2(B\mathrm{Sp}(2g, \mathbb{R})^\delta, \mathbb{Z}) = H^2(\mathrm{Sp}(2g, \mathbb{R}), \mathbb{Z})$  and then on  $H^2(\mathcal{M}_g, \mathbb{Z})$  via  $\rho_g$ . This is the generator of  $H^2(\mathcal{M}_g, \mathbb{Z})$ . Here  $B\mathrm{Sp}(2g, \mathbb{R})^\delta$  denotes the classifying space of the group  $\mathrm{Sp}(2g, \mathbb{R})$  endowed with the discrete topology.

The restricted symplectic group  $\mathrm{Sp}_{\mathrm{res}}(\mathcal{H}_r)$  has a well-known 2-cocycle, which measures the projectivity of the *Berezin-Segal-Shale-Weil metaplectic representation* in the bosonic Fock space (see [103], Chapter 6 and Notes p. 171). Unlike the finite dimensional case, this cocycle is not directly related to the topology of  $\mathrm{Sp}_{\mathrm{res}}(\mathcal{H}_r)$ , since the latter is a contractible Banach-Lie group. However,  $\mathrm{Sp}_{\mathrm{res}}(\mathcal{H}_r)$  admits an embedding into the restricted linear group of Pressley-Segal  $\mathrm{GL}_{\mathrm{res}}^0(\mathcal{H})$  (see [110]), where  $\mathcal{H}$  is the complexification of

$\mathcal{H}_r$ , which possesses a cohomology class of degree 2: the Pressley-Segal class  $PS \in H^2(\mathrm{GL}_{\mathrm{res}}^0(\mathcal{H}), \mathbb{C}^*)$ . The group  $\mathrm{GL}_{\mathrm{res}}^0(\mathcal{H})$  is a homotopic model of the classifying space  $BU$ , where  $U = \varinjlim_{n \rightarrow \infty} U(n, \mathbb{C})$ , and the class  $PS$  does correspond to the universal first Chern class. Its restriction on  $\mathrm{Sp}_{\mathrm{res}}(\mathcal{H}_r)$  is closely related to the Berezin-Segal-Shale-Weil cocycle, and reveals the topological origin of the latter. Via the composition of morphisms

$$\mathcal{M} \longrightarrow \mathrm{Sp}_{\mathrm{res}}(\mathcal{H}_r) \hookrightarrow \mathrm{GL}_{\mathrm{res}}^0(\mathcal{H}),$$

we then derive from  $PS$  an *integral* cohomology class on  $\mathcal{M}$ :

**Theorem 7.11** ([52]). *The Pressley-Segal class  $PS \in H^2(\mathrm{GL}_{\mathrm{res}}^0(\mathcal{H}), \mathbb{C}^*)$  induces the first universal Chern class  $c_1(\mathcal{M}) \in H^2(\mathcal{M}, \mathbb{Z})$ .*

## 8 Cosimplicial extensions for the Thompson group $V$

Various extensions of Thompson's group  $V$  have been encountered in what precedes.

- (1) The extension  $1 \rightarrow P_\infty \rightarrow BV \rightarrow V \rightarrow 1$ , where  $BV$  is the braided Thompson group of Brin-Dehornoy ([13], [14], [32], [33]).
- (2) The extension  $1 \rightarrow K_\infty^* \rightarrow \mathcal{B} \rightarrow V \rightarrow 1$ , where  $\mathcal{B}$  is the universal mapping class group of ([50]).
- (3) The extension  $1 \rightarrow P\mathcal{M} \rightarrow \mathcal{M} \rightarrow V \rightarrow 1$ , where  $\mathcal{M}$  is the asymptotically rigid mapping class group of infinite genus ([52]).

Each one appears in a specific context. It turns out that it is possible to recover all of them by means of a very general and algebraic formalism. More precisely, one may describe a functorial construction which produces this type of extensions for  $V$ . It is defined on a category whose objects are called *cosimplicial  $\mathfrak{S}$ -extensions*, where the letter  $\mathfrak{S}$  stands for the ‘‘symmetric group’’. This formalism, which is inspired from a non-simplicial construction in [40], seems to be quite useful when the appropriate language of the problem is algebraic. This is the case when one wishes to define a convenient profinite completion of the groups  $BV$  or  $\mathcal{B}$ .

### 8.1 Strand doubling maps

For  $n \geq 1$ , let  $S_n$  denote the set  $\{1, \dots, n\}$ , and  $\mathfrak{S}_n$  denote the symmetric group acting on  $S_n$ .

**Definition 8.1.** For each integer  $n \geq 1$  and each  $i = 1, \dots, n$ , the  $i^{\text{th}}$  strand doubling map  $\partial_n^i : \mathfrak{S}_n \rightarrow \mathfrak{S}_{n+1}$  is defined as follows. For any  $\sigma \in \mathfrak{S}_n$ ,  $\partial_n^i(\sigma)$  is the natural extension of  $\sigma$  as a permutation of  $S_{n+1}$  when one simultaneously duplicates  $i$  at the source and the  $\sigma(i)$  at the target. More precisely, let  $\Omega_n^i$  be the set  $\mathbf{n} \setminus \{i\} \cup \{i_l, i_r\}$ , whose elements are those of  $S_n$  except  $i$ , which is replaced by two elements,  $i_l$  and  $i_r$  (where the index  $l$  stands for “left”, and  $r$  for “right”). It is ordered by

$$1 < 2 < \dots < i-1 < i_l < i_r < i+1 < \dots < n.$$

If  $j = \sigma(i)$ , let  $\tau : \Omega_n^i \rightarrow \Omega_n^j$  be the bijection which is the natural extension of  $\sigma$ :  $\tau(k) = k$  if  $k \notin \{i_l, i_r\}$ ,  $\tau(i_l) = j_l$  and  $\tau(i_r) = j_r$ .

The permutation  $\partial_n^i(\sigma) \in \mathfrak{S}_{n+1}$  is the bijection  $f_n^j \circ \tau \circ (f_n^i)^{-1}$ , where  $f_n^k : \Omega_n^k \rightarrow S_{n+1}$ , for  $k = i$  or  $j$ , is the unique isomorphism between the ordered sets  $\Omega_n^k$  and  $S_{n+1}$ .

*Remark 8.1.* The maps  $\partial_n^i$  are not homomorphisms in the category of groups. Nevertheless, they verify the coherence relations:

$$\partial_n^i(\sigma \circ \tau) = \partial_n^{\tau(i)}(\sigma) \partial_n^i(\tau).$$

*Example 8.1.* Let  $\sigma_i \in \mathfrak{S}_n$  be the transposition  $(i, i+1)$ . Then  $\partial_n^i(\sigma_i) = \sigma_i \sigma_{i+1}$ ,  $\partial_n^i(\sigma_{i-1}) = \sigma_i \sigma_{i-1}$ ,  $\partial_n^i(\sigma_j) = \sigma_{j+1}$  if  $i < j$  and  $\partial_n^i(\sigma_j) = \sigma_j$  if  $j < i-1$ .

## 8.2 Cosimplicial $\mathfrak{S}$ -extensions

**Definition 8.2.** A cosimplicial  $\mathfrak{S}$ -extension is a family of group extensions

$$1 \rightarrow K_n \rightarrow G_n \rightarrow \mathfrak{S}_n \rightarrow 1$$

indexed by  $n \in \mathbb{N}^*$ , such that:

- (1) For all  $i = 1, \dots, n$ , the strand doubling map  $\partial_n^i : \mathfrak{S}_n \rightarrow \mathfrak{S}_{n+1}$  admits a lift, still denoted  $\partial_n^i : G_n \rightarrow G_{n+1}$ , which verifies, for all  $g, h \in G_n$ :

$$\partial_n^i(gh) = \partial_n^{\bar{h}(i)}(g) \partial_n^i(h),$$

where  $\bar{h}$  denotes the image of  $h \in G_n$  in  $\mathfrak{S}_n$ .

In particular, each  $\partial_n^i$  restricts to a morphism of groups  $\partial_n^i : K_n \rightarrow K_{n+1}$ .

- (2) There exist morphisms (called codegeneracy morphisms)  $\varepsilon_n^i : K_n \rightarrow K_{n-1}$ , for  $i = 1, \dots, n$ , such that  $(K_n, \partial^i, \varepsilon^i, n \geq 1)$  is a cosimplicial group.

*Remark 8.2.* Since  $\varepsilon_{n+1}^i \circ \partial_n^i = id$ , the morphisms  $\partial_n^i : K_n \rightarrow K_{n+1}$  are injective.

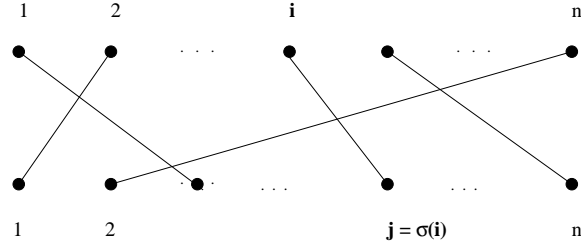

Figure 10. Diagram of strands representing a permutation  $\sigma$

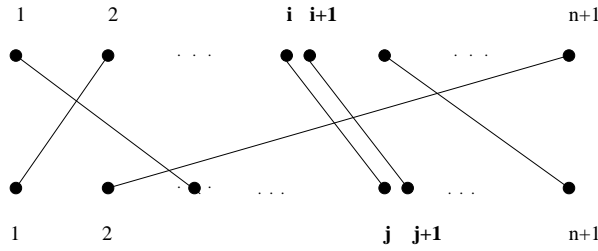

Figure 11. Diagram of strands representing the permutation  $\partial_n^i(\sigma)$

### 8.3 Dyadic trees and the functor $\mathbf{K}$

**Definition 8.3.** (1) Let  $\mathcal{T}_0$  be the planar rooted dyadic tree, whose vertices except the root are 3-valent. Let also  $\mathcal{T}$  be the planar unrooted regular tree, whose vertices are all 3-valent. One may view  $\mathcal{T}_0$  as a subtree of  $\mathcal{T}$ . The edge  $e$  of  $\mathcal{T}$  which is not contained in  $\mathcal{T}_0$  but is incident to the root of  $\mathcal{T}_0$  is called the reference edge of  $\mathcal{T}$ .

(2) A planar rooted finite dyadic  $n$ -tree is a finite subtree of  $\mathcal{T}_0$  which contains the root, has  $n$  leaves, and whose vertices, other than the root and the leaves, are 3-valent. The leaves of such a tree are canonically labelled by  $1, \dots, n$  from left to right, according to the given orientation of the plane.

(3) A planar unrooted finite dyadic  $n$ -tree is a finite subtree of  $\mathcal{T}$  which contains the reference edge  $e$ , has  $n$  leaves, and whose vertices, other than leaves, are 3-valent. The leaves of such a tree are canonically labelled by  $1, \dots, n$  from left to right, according to the given orientation of the plane, assuming that its leftmost leaf belonging to  $\mathcal{T}_0$  is labelled 1.

In short, a planar rooted or unrooted finite dyadic  $n$ -tree will be called a (rooted or unrooted) labelled tree.

- (4) If  $\tau$  is a rooted or unrooted finite  $n$ -tree, then  $|\tau|$  will denote the number of its leaves.

**Definition 8.4** (Category of trees). Let  $\mathbf{T}_0$  (resp.  $\mathbf{T}$ ) be the small category of rooted (resp. unrooted) finite dyadic labelled trees defined as follows.

- Its objects are the rooted (resp. unrooted) finite dyadic labelled trees.
- Let  $\tau$  be an object of  $\mathbf{T}_0$  (resp.  $\mathbf{T}$ ) with  $n$  leaves. If  $1 \leq i \leq n$ , let  $\partial_n^i(\tau)$  be the dyadic tree obtained from  $\tau$  by grafting two edges at its  $i$ -th leaf (such a pair of grafted edges is sometimes called a carret). Since  $\partial_n^i(\tau)$  is planar, it inherits a canonical labelling. The tree  $\partial_n^i(\tau)$  is called a simple expansion of  $\tau$ .

Let now  $\tau$  and  $\tau'$  be two rooted (resp. unrooted) finite dyadic labelled trees. One says that  $\tau'$  is an expansion of  $\tau$  if there exists a chain of simple expansions connecting  $\tau$  to  $\tau'$ . This means that  $n = |\tau| \leq m = |\tau'|$ , and either  $\tau = \tau'$ , or  $\tau' = \partial_{n+k}^{i_{k+1}} \cdots \partial_{n+1}^{i_2} \partial_n^{i_1}(\tau)$ , for some  $i_1, \dots, i_{k+1}$ , with  $m = n + k + 1$ .

By definition,  $\text{Hom}(\tau, \tau')$  is nonempty if and only if  $\tau'$  is an expansion of  $\tau$ , in which case it has a single element. Therefore, the set of all morphisms is the set of pairs  $(\tau, \tau')$ , where  $\tau'$  is an expansion of  $\tau$ .

*Remark 8.3.* (1)  $Ob(\mathbf{T}_0)$  and  $Ob(\mathbf{T})$  are partially ordered sets by setting  $\tau \leq \tau'$  if and only if  $\tau'$  is an expansion of  $\tau$ . They are directed ordered sets, since any two trees have a common expansion.

- (2) The categories  $\mathbf{T}$  and  $\mathbf{T}_0$  are “almost” isomorphic in the following sense. Let  $\tau_3 \in Ob(\mathbf{T})$  be the tripod whose three edges are incident to the root of  $\mathcal{T}_0$ . Let  $\tau_0 \in Ob(\mathbf{T}_0)$  be one of the two rooted 3-trees in  $\mathbf{T}_0$ . Denote by  $\mathbf{T}_{\tau \geq \tau_3}$  the full sub-category of  $\mathbf{T}$  whose objects are the  $n$ -trees which contain  $\tau_3$ , and denote similarly by  $\mathbf{T}_{\tau \geq \tau_0}$  the full sub-category of  $\mathbf{T}_0$  whose objects are the  $n$ -trees which contain  $\tau_0$ . Plainly, the sub-categories  $\mathbf{T}_{\tau \geq \tau_3}$  and  $\mathbf{T}_{0\tau \geq \tau_0}$  are isomorphic.

**Proposition-Definition 8.4.** Let  $\mathbf{G}$  be the category of groups, and  $\mathbf{T}_*$  stand for the category  $\mathbf{T}_0$  or  $\mathbf{T}$ . Let  $(K_n, \partial_n^i, \varepsilon_n^i, n \geq 1)$  be a cosimplicial group. The functor  $\mathbf{K} : \mathbf{T}_* \rightarrow \mathbf{G}$  is defined as follows:

- Let  $\tau \in Ob(\mathbf{T}_*)$ . Set  $\mathbf{K}(\tau) = K_{|\tau|}$ .
- Let  $\varphi \in \text{Hom}(\tau, \tau')$ . Then  $n = |\tau| \leq m = |\tau'|$ . Either  $\tau = \tau'$ , in which case one sets  $\mathbf{K}(\varphi) = 1$ , the neutral element of  $K_n$ . Or  $\tau' = \partial_{n+k}^{i_{k+1}} \cdots \partial_{n+1}^{i_2} \partial_n^{i_1}(\tau)$ , for some  $i_1, \dots, i_{k+1}$ , with  $m = n + k + 1$ . In that case, one sets  $\mathbf{K}(\varphi) = \partial_{n+k}^{i_{k+1}} \circ \cdots \circ \partial_{n+1}^{i_2} \circ \partial_n^{i_1} \in \text{Hom}(K_n, K_m)$ , and this does not depend on the choice of simple expansions which connect  $\tau$  to  $\tau'$ . The functor  $\mathbf{K}$  yields a group  $\mathbf{K}_\infty[\mathbf{T}_*]$  which is the colimit

$$K_\infty[\mathbf{T}_*] = \varinjlim_{\tau \in \mathbf{T}_*} \mathbf{K}(\tau).$$

The groups  $K_\infty[\mathbf{T}]$  and  $K_\infty[\mathbf{T}_0]$  are isomorphic. We denote them by the same symbol  $K_\infty$ .

*Proof.* Two chains of simple expansions between two trees  $\tau$  and  $\tau'$  such that  $\tau \leq \tau'$  may only differ by a repetition of the relation  $\partial_{N+1}^j \circ \partial_N^i(\tau) = \partial_{N+1}^{i+1} \circ \partial_N^j(\tau)$ , where  $\tau$  is a tree such that  $|\tau| = N$ , and  $1 \leq j < i \leq N$ . Since  $(K_n, \partial_n^i, \varepsilon_n^i, n \geq 1)$  is a cosimplicial group, one has  $\partial_{N+1}^j \circ \partial_N^i = \partial_{N+1}^{i+1} \circ \partial_N^j$  in  $\text{Hom}(K_N, K_{N+1})$ . This proves that  $\mathbf{K}(\varphi)$  is well defined.

The isomorphism between  $K_\infty[\mathbf{T}]$  and  $K_\infty[\mathbf{T}_0]$  is a consequence of the second remark of 8.3. □

### 8.4 Extensions of Thompson's group $V$

Let  $VExt$  be the category of extensions of Thompson's group  $V$ . An object is therefore a short exact sequence of groups  $1 \rightarrow K \rightarrow G \rightarrow V \rightarrow 1$ . A morphism between to objects is a commutative diagram of short exact sequences.

**Proposition 8.5.** *There exists a functor from the category  $\mathfrak{S}Ext$  to the category  $VExt$ , which maps a cosimplicial  $\mathfrak{S}$ -extension  $(1 \rightarrow K_n \rightarrow G_n \rightarrow \mathfrak{S}_n \rightarrow 1)$  to an extension of Thompson's group  $V$  by  $K_\infty$ :*

$$1 \rightarrow K_\infty \rightarrow G[V] \rightarrow V \rightarrow 1$$

which is split over Thompson's group  $V$ .

In particular, the correspondence which associates the group  $G[V]$  to the cosimplicial  $\mathfrak{S}$ -extension is a functor from  $\mathfrak{S}Ext$  to the category of groups.

*Proof.* In the following,  $\mathbf{T}_*$  will equally denote the category  $\mathbf{T}_0$  or the category  $\mathbf{T}$ . The isomorphism classes of groups or short exact sequence of groups constructed below will not depend on the choice for  $\mathbf{T}_*$ .

Let  $\mathcal{S}(G)$  be the following set, whose elements are called  $G$ -symbols. A  $G$ -symbol is a triple  $(\tau_1, \tau_0, g)$ , where  $\tau_0$  and  $\tau_1$  are two objects of  $\mathbf{T}$  with the same number of leaves, say  $n \geq 1$ , and  $g$  is an element of the group  $G_n$ . The integer  $n$  is called the level of the  $G$ -symbol  $(\tau_1, \tau_0, g)$ .

One defines a set of binary relations denoted  $\sim_{n,i}$ , for each integer  $n \geq 1$  and  $1 \leq i \leq n$ . By definition,  $\sim_{n,i}$  relates a symbol  $(\tau_1, \tau_0, g)$  of level  $n$  to the symbol  $(\partial_n^{\bar{g}^{(i)}}(\tau_1), \partial_n^i(\tau_0), \partial_n^i(g))$  of level  $n + 1$ .

Let now  $\mathcal{R}$  be the equivalence relation generated by the set of relations  $\sim_{n,i}$  on  $\mathcal{S}(G)$ . An equivalence class is denoted  $[\tau_1, \tau_0, g]$ .

The group  $G[V]$  is defined as follows. Its elements are the equivalence classes of symbols  $\mathcal{S}(G)/\mathcal{R}$ . Let  $[\tau_1, \tau_0, h]$  and  $[\tau_2, \tau_1', g]$  be two elements. At the price

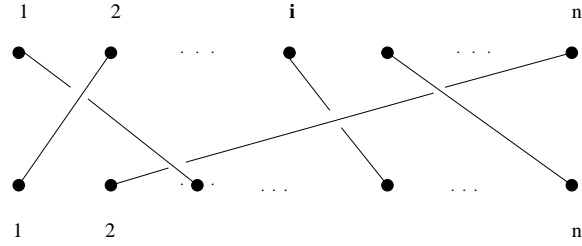

Figure 12. Diagram of strands representing a braid  $\sigma$

of replacing both symbols by equivalent ones, one may assume that  $\tau'_1 = \tau_1$ . Set

$$[\tau_2, \tau_1, g] \cdot [\tau_1, \tau_0, h] = [\tau_2, \tau_0, gh].$$

The point is that the above definition of a product of two elements of  $\mathcal{S}(G)/\mathcal{R}$  only depends on the equivalence classes, not on the choice of the symbols. The neutral element is the class of any symbol  $(\tau, \tau, 1_n)$ , where  $\tau$  is any tree,  $n$  is its level, and  $1_n \in G_n$  is the neutral element of  $G_n$ .

For each  $\tau \in Ob(\mathbf{T}_*)$ , there is a morphism  $\iota_\tau : \mathbf{K}(\tau) \rightarrow G[V]$ ,  $k \mapsto [\tau, \tau, k]$ . If  $\tau \leq \tau'$  and  $\varphi$  is the unique morphism from  $\tau$  to  $\tau'$ , then  $\iota_\tau = \iota_{\tau'} \circ \mathbf{K}(\varphi)$ . This implies the existence of a morphism  $\iota_\infty : K_\infty \rightarrow G[V]$  induced by the  $\iota_\tau$ 's. Since the morphisms  $\partial_n^i$  are injective, so is the morphism  $\iota_\infty$ .

When  $G_n = \mathfrak{S}_n$  (hence  $K_n = \{1\}$ ), the group  $G[V]$  is denoted  $V$ , and is the Thompson group acting on the Cantor set. The subgroup of  $V$  whose elements are of the form  $[\tau_1, \tau_0, 1_n]$ , for any pair of  $n$ -trees  $(\tau_1, \tau_0)$ , and any  $n \geq 1$ , is Thompson's group  $F$ .

The morphism  $G[V] \rightarrow V$  is defined by  $[\tau_1, \tau_0, g] \mapsto [\tau_1, \tau_0, \bar{g}]$ . It is surjective, and its kernel is  $K_\infty$ . The splitting over Thompson's group  $F$  is the morphism  $[\tau_1, \tau_0, 1_n] \in F \mapsto [\tau_1, \tau_0, 1_n] \in G[V]$  (where  $1_n$  denotes the neutral element of  $\mathfrak{S}_n$  in the left symbol, and the neutral element of  $G_n$  in the right symbol). The functoriality of this construction can be easily checked. □

### 8.5 Main examples

**The braided Thompson group  $BV$**  The family of extensions  $1 \rightarrow P_n \rightarrow B_n \rightarrow \mathfrak{S}_n \rightarrow 1$ ,  $n \geq 1$ , is a cosimplicial  $\mathfrak{S}$ -extension, with  $\partial_n^i$  the obvious geometric strand doubling map, and  $\varepsilon_n^i : P_n \rightarrow P_{n-1}$  the morphism obtained by deleting the  $i^{th}$  braid.

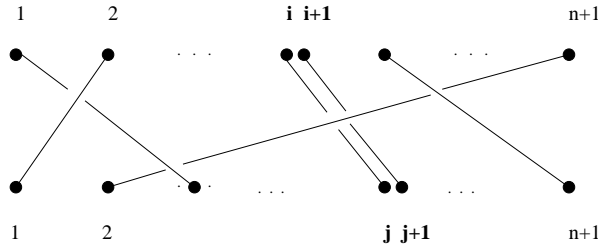

Figure 13. Diagram of strands representing the braid  $\partial_n^i(\sigma)$

The group  $B[V]$  is the braided Thompson group  $BV$  discovered independently by Brin and Dehornoy ([13], [14],[32], [33]).

**The universal mapping class group in genus zero  $\mathcal{B}$**  In [50] we construct the group  $\mathcal{B}$  as a mapping class group of a sphere minus a Cantor set. The surface  $\mathcal{S}_{0,\infty}$  is the boundary of the 3-dimensional thickening of a regular (unrooted) dyadic tree. The definition of  $\mathcal{B}$  given in [50] is therefore completely topological. We wish to give an equivalent one using the formalism of cosimplicial  $\mathfrak{S}$ -extensions.

**Mapping class groups  $M^*(0, n)$**

- Definition 8.5.** (1) Let  $S$  be an  $n$ -holed sphere, that is, a sphere minus  $n$  disjoint embedded open disks. Its *pure mapping class group*  $K^*(S)$  is the group of isotopy classes of orientation-preserving homeomorphisms of  $S$ . The homeomorphisms and the isotopies are assumed to fix pointwise the  $n$  boundary circles.
- (2) Suppose we have chosen two base points on each boundary circle of  $S$ ,  $p_+$  and  $p_-$ . The full mapping class group  $M^*(S)$  is the group of isotopy classes of orientation-preserving homeomorphisms of the holed sphere  $S$  which permute the boundary circles and the set of base points, preserving their signs. The isotopies are only assumed to fix the base points. If the set of boundary components is labelled by  $\{1, \dots, n\}$ , then  $K^*(S)$  and  $M^*(S)$  are related by a short exact sequence

$$1 \rightarrow K^*(S) \longrightarrow M^*(S) \longrightarrow \mathfrak{S}_n \rightarrow 1.$$

**Proposition 8.6.** *The family of group extensions  $1 \rightarrow K^*(0, n) \longrightarrow M^*(0, n) \longrightarrow \mathfrak{S}_n \rightarrow 1$ ,  $n \geq 1$ , forms a cosimplicial  $\mathfrak{S}$ -extension.*

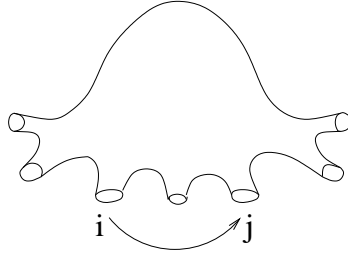

Figure 14. The mapping class  $\sigma \in M^*(0, n)$  permuting the  $i^{th}$  and  $j^{th}$  boundary circles

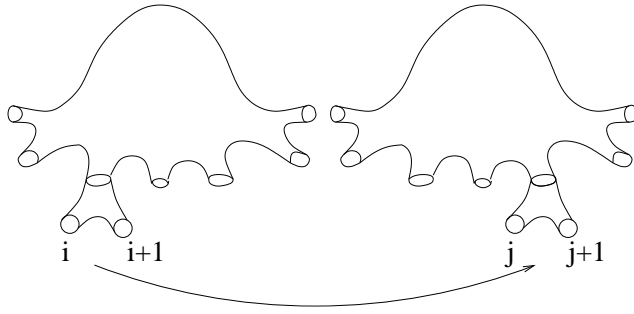

Figure 15. The mapping class  $\partial_n^i(\sigma) \in M^*(0, n + 1)$

The strand doubling map  $\partial_n^i : \sigma \in M^*(0, n) \mapsto \partial_n^i(\sigma) \in M^*(0, n+1)$  is deduced from the topological operation consisting in gluing a pair of pants  $P_i$  (resp.  $P_{\sigma(i)}$ ) along the  $i^{th}$  (resp.  $\sigma(i)^{th}$ ) boundary circle of the  $n$ -holed reference surface  $\Sigma_{0,n}$ , then defining the natural extension of  $\sigma$  as a (mapping class of) homeomorphism  $\Sigma_{0,n} \cup P_i \rightarrow \Sigma_{0,n} \cup P_{\sigma(i)}$ , and finally identifying  $\Sigma_{0,n} \cup P_i$  and  $\Sigma_{0,n} \cup P_{\sigma(i)}$  to  $\Sigma_{0,n+1}$  to obtain the expected  $\partial_n^i(\sigma)$ .

The codegeneracy morphisms  $\varepsilon^i : K^*(0, n) \rightarrow K^*(0, n - 1)$  are induced by the topological operation consisting in filling up the  $i^{th}$  hole of  $\Sigma_{0,n}$  with a disk, and identifying the resulting surface to  $\Sigma_{0,n-1}$ .

**Proposition 8.7.** *The cosimplicial  $\mathfrak{S}$ -extension  $(1 \rightarrow K^*(0, n) \rightarrow M^*(0, n) \rightarrow \mathfrak{S}_n \rightarrow 1, n \geq 1)$ , yields the extension of Thompson's group  $V$*

$$1 \rightarrow K_\infty^* \rightarrow M^*[V] \rightarrow V \rightarrow 1$$

by the construction of Proposition 8.5. The group  $M^*[V]$  is isomorphic to the universal mapping class group  $\mathcal{B}$  defined in [50].

**Profinite completions**

**Proposition 8.8.** *Each strand doubling map  $\partial_n^i : M^*(0, n) \rightarrow M^*(0, n+1)$  extends to a map  $\widehat{\partial}_n^i : \widehat{M}^*(0, n) \rightarrow \widehat{M}^*(0, n+1)$  between the profinite completions of the corresponding groups.*

See [82] for a proof.

**Proposition-Definition 8.9.** *The cosimplicial  $\mathfrak{S}$ -extension  $(1 \rightarrow \widehat{K}^*(0, n) \rightarrow \widehat{M}^*(0, n) \rightarrow \mathfrak{S}_n \rightarrow 1, n \geq 1)$ , yields the extension of Thompson’s group  $V$*

$$1 \rightarrow \widehat{K}_\infty^* \rightarrow \widehat{M}^*[V] \rightarrow V \rightarrow 1$$

by the construction of Proposition 8.5.

The group  $\widehat{M}^*[V]$ , which will be denoted  $\widehat{\mathcal{B}}$  in the sequel, is called the  $V$ -profinite completion of the universal mapping class group of genus zero. The group  $\widehat{K}_\infty^*$  is an inductive limit of the profinite completions of the pure mapping class groups  $K^*(0, n)$ . The group  $\widehat{\mathcal{B}}$  is related to  $\mathcal{B}$  via the commutative diagram

$$\begin{array}{ccccccc}
 1 & \longrightarrow & \widehat{K}_\infty^* & \longrightarrow & \widehat{\mathcal{B}} & \longrightarrow & V \longrightarrow 1 \\
 & & \uparrow & & \uparrow & & \parallel \\
 1 & \longrightarrow & K_\infty^* & \longrightarrow & \mathcal{B} & \longrightarrow & V \longrightarrow 1
 \end{array}$$

The morphism  $K_\infty^* \rightarrow \widehat{K}_\infty^*$  is induced by the collection of natural morphisms  $K^*(0, n) \rightarrow \widehat{K}^*(0, n)$ . All vertical arrows are injective.

**Embeddings  $BV \subset \mathcal{B}$  and  $\widehat{BV} \subset \widehat{\mathcal{B}}$**  The Artin braid group  $B_n$  embeds into  $M^*(0, n+1)$ . The family of embeddings  $B_n \hookrightarrow M^*(0, n+1)$  indexed by  $n$  induces in turn an embedding  $BV \subset \mathcal{B}$ . After applying the functor of profinite completion, one obtains morphisms  $\widehat{B}_n \rightarrow \widehat{M}^*(0, n+1)$  which are still injective. Hence an embedding  $\widehat{BV} \subset \widehat{\mathcal{B}}$ .

**8.6 The universal mapping class group in genus zero and the Grothendieck-Teichmüller group**

Not only does the group  $\mathcal{B}$  of [50] contain all the mapping class groups of compact surfaces of genus zero, but it also encodes their mutual relations. Otherwise stated, all the information contained in the modular tower of genus zero is encoded in the group  $\mathcal{B}$ . We wish to give a remarkable illustration of this idea, as well as an example of application of the formalism of cosimplicial

$\mathfrak{S}$ -extensions.

In the article [34], Drinfeld defined a group containing the absolute Galois group  $Gal(\overline{\mathbb{Q}}, \mathbb{Q})$ , and called it the Grothendieck-Teichmüller group  $\widehat{GT}$ . Explicit formulas of the action of the Grothendieck-Teichmüller group (in its  $k$ -pro-unipotent version) on the  $k$ -pro-unipotent completions of the braid groups were given. Similar formulas hold for the profinite version, and the corresponding action of  $\widehat{GT}$  extends the natural action of  $Gal(\overline{\mathbb{Q}}, \mathbb{Q})$  on the profinite completions  $\widehat{B}_n$  of the braid groups. A fundamental remark is that the action of  $\widehat{GT}$  on the  $\widehat{B}_n$ 's respects not only the obvious embeddings  $\widehat{B}_n \rightarrow \widehat{B}_{n+1}$  ("adding one strand"), but also the strand doubling maps  $\widehat{\partial}^i : \widehat{B}_n \rightarrow \widehat{B}_{n+1}$ . The action of  $\widehat{GT}$  extends to the profinite completions  $\widehat{M}^*(0, n)$  of the mapping class groups of holed spheres, preserving the analogous "strand doubling maps", (topologically corresponding to a pair of pants glueing)  $\widehat{\partial}^i$ . The action of  $\widehat{GT}$  on the Teichmüller tower in genus zero has been systematically studied in [20].

Since  $\widehat{GT}$  acts on the  $\widehat{M}^*(0, n)$ 's respecting the maps  $\widehat{\partial}^i$ , the formalism of cosimplicial  $\mathfrak{S}$ -extensions enables us easily to prove that it extends to the completion  $\widehat{\mathcal{B}}$ . Denoting  $\alpha, \beta, \pi$  and  $t$  the images in  $\widehat{\mathcal{B}}$  of the generators of  $\mathcal{B}$ , one can easily obtain the following :

**Theorem 8.10** ([82]). *The Grothendieck-Teichmüller group  $\widehat{GT}$  acts on the group  $\widehat{\mathcal{B}}$ . Moreover, denoting by  $(\lambda, f) \in \widehat{\mathbb{Z}} \times \widehat{F}_2$  an element of  $\widehat{GT}$ , the action reads on the generators as follows:*

$$(\lambda, f).(\pi) = \pi^\lambda$$

$$(\lambda, f).(t) = t^\lambda$$

$$(\lambda, f)(\alpha) = \alpha f(t, \alpha t \alpha^{-1})$$

$$(\lambda, f)(\beta) = \beta.$$

It is quite remarkable that the action of  $\widehat{GT}$  turns out to be completely defined by 4 formulas (3 would suffice, as the generator  $t$  is redundant). Moreover, if one assumes that a pair  $(\lambda, f)$  defines an automorphism of  $\widehat{\mathcal{B}}$  given by the above formulas on the generators, then  $(\lambda, f)$  satisfies the three relations characterizing its belonging to  $\widehat{\mathcal{B}}$ . Therefore, the presentation of the group  $\mathcal{B}$  encodes the definition of the Grothendieck-Teichmüller group  $\widehat{GT}$ .

## 9 Problems

**Problem 1.** *Are the groups  $F, T, V$  or their generalizations  $T^*, \mathcal{B}$  automatic? More generally are they (synchronously) combable? In the affirmative case this would imply that braided Thompson groups are of type  $F_\infty$ .*

A directly related question is the one for the braided Houghton groups.

**Problem 2.** *Find out whether  $\mathcal{M}_\partial(Y_n^\sharp)$  are  $F_{n-1}$  but not  $F_n$ .*

Degenhardt ([31]) proved that the braided Houghton groups are  $F_{n-1}$  but not  $F_n$  for  $n \leq 3$  and conjectured that this holds for all  $n$ . This would be a parallel to the results obtained by Brown (see [18]) for the usual Houghton groups  $H_n$ . Progress towards the settlement of this conjecture was made by Kai-Uwe Bux in [23].

This behavior is in contrast with the case of the Thompson group  $T$  (which is  $\text{FP}_\infty$ ) and its braided version  $T^*$  (which is at least  $\text{FP}_3$  (see [53]) and expected to be  $\text{FP}_\infty$ ). It is therefore likely that  $\mathcal{M}_\partial(Y_n^\sharp)$  are not combable (hence not automatic) although the result of [53] would suggest that they might be asynchronously combable with quadratic Dehn function. If the similarity with the braid groups is pushed one step further then the braided Houghton groups should have solvable conjugacy problem as well.

One does not know which other planar graphs yield finitely presented asymptotically rigid mapping class groups. One may enlarge the category of graphs to that of colored graphs, in which automorphisms and almost automorphisms are required to preserve the coloring.

An interesting class of colored planar trees comes from universal coverings of ribbon graphs associated to punctured surfaces and 2-dimensional orbifolds. The ribbon structure of the graph is a cyclic order around each vertex. There is a natural coloring of vertices and edges of the graph and this induces a coloring on the universal covering tree. Moreover, the tree has a natural embedding in the plane which uses the induced cyclic order around the vertices.

However P. Greenberg ([66]) showed that asymptotically rigid mapping class groups of universal coverings of (colored) ribbon graphs (called projective Thompson groups) have infinitely many generators, as soon as the genus of the surface is positive. Moreover, if the genus is zero, Laget [89] proved that the asymptotic mapping class groups are finitely presented groups. It seems that the finite presentability holds more generally for all the groups obtained from the 2-orbifolds of genus zero. The basic example in this respect is the Thompson group  $T$  which arises from the 2-orbifold associated to the group  $\text{PSL}(2, \mathbb{Z})$ , namely the sphere with a cusp, one singular point of order 2 and another one of order 3.

We proved in [52] that the universal mapping class group  $\mathcal{M}$  of infinite genus is finitely generated. Also the Greenberg-Sergiescu acyclic extension  $A_T$  was proved in [55] to be finitely generated. The present methods do not permit to settle the following

**Problem 3.** *Are the groups  $\mathcal{M}$  or  $A_T$  finitely presented or even of type  $F_\infty$  ?*

A fundamental theorem of Tillmann (see [116, 117]) states that the plus construction of the classifying space  $B\Gamma_\infty$  of the infinite genus mapping class group  $\Gamma_\infty = \lim_{g \rightarrow \infty} \Gamma_{g,1}$  is an infinite loop space. This is a key ingredient in the Madsen-Weiss proof of the Mumford conjecture (see [94, 95]). The second proof of Tillmann's theorem ([117]) uses Segal's surfaces category whose objects are compact oriented 1-manifolds and whose morphisms are Riemann surfaces cobording the respective objects. Tillmann actually shows that the operad associated to Segal's category detects the infinite loop spaces. In this context it would be interesting to know whether we could replace  $\Gamma_\infty$  by  $\mathcal{M}$  and we also propose the following:

**Problem 4.** *Find a geometric interpretation of the acyclicity of the group  $A$ . Is the plus construction of the classifying space  $B\mathcal{M}$  an infinite loop space?*

In [30] the authors considered the Teichmüller space of quasiconformal asymptotically conformal structures on  $\Sigma_{0,\infty}$  minus a disk. They showed that  $F$  is the automorphism group of this Teichmüller space.

**Problem 5.** *Is there a similar interpretation for the groups  $\mathcal{B}$  and  $\mathcal{M}$ , for instance?*

Another setting where the group  $T$  acts as a mapping class group is that of Greenberg's space  $\mathcal{G}r = \text{CPP}_{\mathbb{Q}}/\text{PSL}(2, \mathbb{R})$ , which is sometimes called the Teichmüller space associated to  $T$  (see [67, 97]). Here  $\text{CPP}_{\mathbb{Q}}$  is the space of piecewise  $\text{PSL}(2, \mathbb{R})$  functions  $f : P_{\mathbb{R}}^1 \rightarrow P_{\mathbb{R}}^1$  on the projective circle  $P_{\mathbb{R}}^1$  whose breaking points are rational. The space  $\mathcal{G}r$  is contractible and the action of  $F$  on it is free. Thus  $\mathcal{G}r/F'$  is a  $BF'$  and one could use this model to build a homology equivalence  $BF' \rightarrow \Omega S^3$ , by making further use of James' model of a loop space.

**Problem 6.** *Is it possible to interpret  $T$  as the group of automorphisms of the space  $\mathcal{G}r$  equipped with some convenient structure?*

## References

- [1] J. M. Alonso, Combings of groups, *Algorithms and Classification in Combinatorial Group Theory*, Berkeley 1989 (Eds. G.Baumslag, C.F.Miller III), 165-178, MSRI Series 23, Springer-Verlag, 1992.
- [2] T. Altinel and A. Muranov, Interprétation de l'arithmétique dans certains groupes de permutations affines par morceaux d'un intervalle, *J. Inst. Math. Jussieu* 8 (2009), 623–652.
- [3] H. Bai, F. Bonahon and X. Liu, Local representations of the quantum Teichmüller space, [math.GT/0707.2151](https://arxiv.org/abs/math.GT/0707.2151).
- [4] B. Bakalov and A. Kirillov Jr., *Lectures on tensor categories and modular functors*, University Lecture Series 21, A. M. S., 2001.
- [5] B. Bakalov and A. Kirillov Jr., On the Lego-Teichmüller game, *Transform. Groups* 5 (2000), 207-244.
- [6] V. Bardakov and V. Tolstykh, Interpreting the arithmetic in Thompson's group  $F$ , *J. Pure Appl. Algebra* 211 (2007), no. 3, 633–637.
- [7] E. W. Barnes, The genesis of the double gamma function, *Proc. London Math. Soc.* 31 (1899), 358-381.
- [8] R. Baxter, *Exactly solved models in statistical mechanics*, Academic Press, London 1989.
- [9] J. -C. Birget, Factorisations of the Thompson-Higman groups and complexity, *Internat. J. Algebra Comput.* 18(2) (2008), 285–320.
- [10] N. Brady, Sol geometry groups are not asynchronously automatic, *Proc. London Math. Soc.* (3) 83 (2001), 93-119.
- [11] M. R. Bridson, On the geometry of normal forms in discrete groups, *Proc. London Math. Soc.* (3) 67 (1993), 596-616.
- [12] M. R. Bridson, Combings of semidirect products and 3-manifold groups, *Geom. Funct. Analysis* 3 (1993), 263-278.
- [13] M. G. Brin, The algebra of strand splitting. I. A braided version of Thompson's group  $V$ , *J. Group Theory* 10 (2007), 757–788.
- [14] M. G. Brin, The algebra of strand splitting. II. A presentation for the braid group on one strand, *Internat. J. Algebra Comput.* 16 (2006), 203–219.
- [15] M. G. Brin, The chameleon groups of Richard J. Thompson: automorphisms and dynamics. *Inst. Hautes Études Sci. Publ. Math.* No. 84 (1996), 5–33 (1997).
- [16] M. G. Brin, The free group of rank 2 is a limit of Thompson's group  $F$ , *Groups Geom. Dyn.* 4 (2010), 433–454.
- [17] K. S. Brown and R. Geoghegan, An infinite-dimensional torsion-free  $FP_\infty$  group, *Invent. Math.* 77 (1984), no. 2, 367–381.
- [18] K. S. Brown, Finiteness properties of groups, *J. Pure Appl. Algebra* 44 (1987), 45–75.

- [19] K. S. Brown, The Geometry of Finitely Presented Infinite Simple Groups, *Algorithms and Classification in Combinatorial Group Theory* (G. Baumslag and C. F. Miller III, eds), 121–136, MSRI Publications, 23, Springer-Verlag, 1992.
- [20] X. Buff, J. Fehrenbach, P. Lochak, L. Schneps and P. Vogel, *Espaces de modules des courbes, groupes modulaires et théorie des champs*, Panoramas et Synthèses, No 7, 1999.
- [21] J. Burillo, S. Cleary and C. Rover, Comensurators and subgroups of finite index of Thompson’s group  $F$ , *Geom. Topol.* 12 (2008), 1701–1709.
- [22] M. Burger and S. Mozes, Lattices in product of trees, *Inst. Hautes Études Sci. Publ. Math.* No. 92 (2000), 151–194 (2001).
- [23] K. -U. Bux, Braiding and tangling the chessboard complex, math.GT/0310420.
- [24] D. Calegari, Circular groups, Planar groups and the Euler class, *Proceedings of the Casson Fest*, Geom. Topol. Monogr. 7 (2004), 431–491.
- [25] D. Calegari, Denominator bounds in Thompson-like groups and flows, *Groups Geom. Dyn.* 1(2007), 101–109.
- [26] J. W. Cannon, W. J. Floyd and W. R. Parry, Introductory notes on Richard Thompson’s groups, *Enseign. Math.* 42 (1996), 215–256.
- [27] L. D. Chekhov and V. Fock, Quantum Teichmüller space, math.QA/9908165.
- [28] L. D. Chekhov and R. C. Penner, On quantizing Teichmüller and Thurston theories, *Handbook of Teichmüller theory*, vol. I, EMS Publishing House, Zürich 2007, 579–645.
- [29] M. Davis, T. Januszkiewicz and R. Scott, Fundamental groups of minimal blow-ups Fundamental groups of blow-ups, *Advances Math.* 177 (2003), no. 1, 115–179.
- [30] E. de Faria, F. Gardiner and W. Harvey, Thompson’s group as a Teichmüller mapping class group, *Contemporary Math.* 355, 2004, 165–185.
- [31] F. Degenhardt, Endlichkeitseigenschaften gewisser Gruppen von Zöpfen unendlicher Ordnung, PhD thesis, Frankfurt 2000.
- [32] P. Dehornoy, Geometric presentations for Thompson’s groups, *J. Pure Appl. Algebra* 203 (2005), 1–44.
- [33] P. Dehornoy, The group of parenthesized braids. *Advances Math.* 205 (2006), 354–409.
- [34] V. G. Drinfel’d, On quasitriangular quasi-Hopf algebras and on a group that is closely connected with  $\text{Gal}(\overline{\mathbb{Q}}/\mathbb{Q})$ , *Algebra i Analiz* 2 (1990), no. 4, 149–181; translation in *Leningrad Math. J.* 2 (1991), no. 4, 829–860.
- [35] I. A. Dynnikov, Three-page representation of links, *Uspekhi Mat. Nauk* 53 (1998), 237–238; translation in *Russian Math. Surveys* 53 (1998), 1091–1092.
- [36] D. B. A. Epstein, J. W. Cannon, D. F. Holt, S. V. F. Levy, M. S. Paterson and W.P. Thurston, *Word processing in groups*, Jones and Bartlett Publishers, Boston, MA, 1992.

- [37] L. D. Faddeev, Discrete Heisenberg-Weyl group and modular group, *Lett. Math. Phys.* 34 (1995), 249-254.
- [38] D. S. Farley, Finiteness and CAT(0) properties of diagram groups, *Topology* 42 (2003), 1065-1082.
- [39] D. S. Farley, Proper isometric actions of Thompson's groups on Hilbert space, *Int. Math. Res. Not.* 2003, no. 45, 2409-2414.
- [40] Z. Fiedorowicz and J. -L. Loday, Crossed-simplicial groups and their associated homology, *Trans. Amer. Math. Soc.* 329 (1991), no.1, 57-87.
- [41] M. Fiori and T. Leinster, An abstract characterisation of Thompson group  $F$ , *Semigroup Forum* 80 (2010), 325-340.
- [42] V. Fock, Dual Teichmüller spaces, math.DG-GA/9702018.
- [43] V. Fock and A. B. Goncharov, Moduli spaces of local systems and higher Teichmüller theory, *Inst. Hautes Études Sci. Publ. Math.* no.103, 2006, 1-211.
- [44] V. Fock and A. B. Goncharov, Moduli spaces of convex projective structures on surfaces, *Advances Math.* 208 (2007), 249-273.
- [45] V. Fock and A. B. Goncharov, The quantum dilogarithm and unitary representations of cluster modular groupoids, *Invent. Math.* 175 (2009), 223-286.
- [46] V. Fock and A. B. Goncharov, Cluster ensembles, quantization and the dilogarithm II: The intertwiner, arXiv:math/0702398.
- [47] L. Funar, Ptolemy groupoids actions on Teichmüller spaces, *Modern Trends in Geometry and Topology*, Deva, Romania 2005, (D. Andrica, P. Blaga, S. Moroianu, Eds.), Cluj Univ. Press 2006, p.185-201.
- [48] L. Funar, Braided Houghton groups as mapping class groups, *Annales Sci. Univ. "A.I.Cuza" Jassy*, special vol. to the memory of Gh. Ionesei, 53 (2007), 229-240.
- [49] L. Funar and R. Gelca, On the groupoid of transformations of rigid structures on surfaces, *J. Math. Sci., Univ. Tokyo* 6 (1999), 599-646.
- [50] L. Funar and C. Kapoudjian, On a universal mapping class groups of genus zero, *Geom. Funct. Analysis* 14 (2004), 965-1012.
- [51] L. Funar and C. Kapoudjian, The braided Ptolemy-Thompson group is finitely presented, *Geometry & Topology* 12 (2008), 475-530.
- [52] L. Funar and C. Kapoudjian, An infinite genus mapping class group and stable cohomology, *Commun. Math. Physics* 287 (2009), 787-804.
- [53] L. Funar and C. Kapoudjian, The Ptolemy-Thompson group  $T^*$  is asynchronously combable, *Comment. Math. Helv.*, to appear, 47p., math.GT/0602490.
- [54] L. Funar and R. Kashaev, Centrally extended mapping class groups from quantum Teichmüller theory, arXiv:1003.5365.
- [55] L. Funar and V. Sergiescu, Central extensions of the Ptolemy-Thompson group and quantized Teichmüller theory, *J. Topology* 3 (2010), 29-62.

- [56] R. Geogheghan, *Topological methods in group theory*, Graduate Texts in Mathematics 243, Springer, New York, 2008.
- [57] R. Geogheghan and F. Guzman, Associativity and Thompson's group, *Topological and asymptotic aspects of group theory*, 113–135, Contemp. Math. 394, Amer. Math. Soc., 2006.
- [58] S. M. Gersten, Finiteness properties of asynchronously automatic groups, *Geometric group theory* (Columbus, 1992), 121–133, Ohio State Univ. Math. Res. Inst. Publ., vol. 3, de Gruyter, Berlin, 1995.
- [59] S. M. Gersten and H. Short, Small cancellation theory and automatic groups II, *Invent. Math.* 105 (1991), 641–662.
- [60] S. Gervais, A finite presentation of the mapping class group of a punctured surface, *Topology* 40 (2001), no. 4, 703–725.
- [61] S. Gervais, Presentation and central extensions of mapping class groups, *Trans. Amer. Math. Soc.* 348 (1996), 3097–3132.
- [62] E. Ghys, Groups acting on the circle, *Enseign. Math.* (2) 47 (2001), 329–407.
- [63] E. Ghys and V. Sergiescu, Sur un groupe remarquable de difféomorphismes du cercle, *Comment. Math. Helv.* 62 (1987), 185–239.
- [64] V. Ginzburg and M. Kapranov, Koszul duality for operads, *Duke Math. J.* 76 (1994), no. 1, 203–272.
- [65] A. B. Goncharov, Pentagon relation for the quantum dilogarithm and quantized  $\mathcal{M}_{0,5}^{\text{cyc}}$ , *Geometry and dynamics of groups and spaces, In memory of Alexander Reznikov* (M. Kapranov, S. Kolyada, Yu. I. Manin, P. Moree and L. Potyagailo Ed.), 415–428, Progr. Math., 265, Birkhäuser, Basel, 2008.
- [66] P. Greenberg, Projective aspects of the Higman-Thompson group, *Group theory from a geometrical viewpoint* (Trieste, 1990), 633–644, World Sci. Publ., River Edge, NJ, 1991.
- [67] P. Greenberg, Les espaces de bracelets, les complexes de Stasheff et le groupe de Thompson, Papers in honor of José Adem (Spanish), *Bol. Soc. Mat. Mexicana* (2) 37 (1992), no. 1-2, 189–201.
- [68] P. Greenberg and V. Sergiescu, An acyclic extension of the braid group, *Comment. Math. Helv.* 66 (1991), 109–138.
- [69] R. I. Grigorchuk, V. V. Nekrashevich and V. I. Sushchanskii, Automata, dynamical systems and infinite groups, *Proc. Steklov Inst. Math.* 231 (2000), 134–214.
- [70] A. Grothendieck, Esquisse d'un programme, dans *Geometric Galois Actions 1. Around Grothendieck's esquisse d'un Programme*, édité par L. Schneps et P. Lochak, London Mathematical Society, Lecture Note Series 242.
- [71] V. Guba, Polynomial isoperimetric inequalities for Richard Thompson's groups  $F$ ,  $T$ , and  $V$ , *Algorithmic problems in groups and semigroups* (Lincoln, NE, 1998), 91–120, *Trends Math.*, Birkhäuser Boston, Boston, MA, 2000.

- [72] V. Guba, The Dehn function of Richard Thompson's group  $F$  is quadratic, *Invent. Math.* 163 (2006), 313–342.
- [73] V. Guba and M. Sapir, Diagram groups, *Mem. Amer. Math. Soc.* 130 (1997), no. 620.
- [74] U. Haagerup and G. Picioroaga, New presentations of Thompson's groups and applications, *J. of Operator Theory*, to appear.
- [75] J. Harer, Stability of the homology of the mapping class groups of orientable surfaces. *Ann. of Math.* (2) 121 (1985), no. 2, 215–249.
- [76] A. Hatcher, P. Lochak et L. Schneps, On the Teichmüller tower of mapping class groups, *J. Reine Angew. Math.*, 521 (2000), 1-24.
- [77] A. Hatcher et W. Thurston, A presentation for the mapping class group of a closed orientable surface, *Topology* 19 (1980), 221–237.
- [78] M. Imbert, Sur l'isomorphisme de Richard Thompson avec le groupe de Ptolémée, 313–324, *Geometric Galois actions*, 2, London Math. Soc., Lecture Note Ser., 243, Cambridge Univ. Press, Cambridge, 1997.
- [79] P. Jolissaint, *Operators algebra related to Thompson's group F*, J. Aust. Math. Soc. 79 (2005), 231–241.
- [80] C. Kapoudjian, *Sur des généralisations  $p$ -adiques du groupe des difféomorphismes du cercle*, Thèse de Doctorat, Université Claude Bernard Lyon 1, décembre 1998.
- [81] C. Kapoudjian, From symmetries of the modular tower of genus zero real stable curves to an Euler class for the dyadic circle, *Compositio Mathematica*, 137 (2003), 49–73.
- [82] C. Kapoudjian, Cosimplicial  $\mathfrak{S}$ -extensions and Thompson's group  $V$ . An application to the Grothendieck-Teichmüller theory, preprint.
- [83] C. Kapoudjian, Finiteness and homological properties of the Thompson-Coxeter group of type  $B$ , in preparation.
- [84] C. Kapoudjian et V. Sergiescu, An extension of the Burau representation to a mapping class group associated to Thompson's group  $T$ , *Geometry and dynamics*, Amer. Math. Soc. , Vol. 389 , 141–164 (2005).
- [85] R. Kashaev, Quantization of Teichmüller spaces and quantum dilogarithm, *Lett. Math. Phys.* 43 (1998), 105-115.
- [86] R. Kashaev, On quantum moduli space of flat  $\mathrm{PSL}(2, \mathbb{R})$ -connections on a punctured surface, *Handbook of Teichmüller theory*, vol. I, EMS Publishing House, Zürich 2007, 761-782.
- [87] F. Knudsen, The projectivity of the moduli space of stable curves. II. The stacks  $M_{g,n}$ , *Math. Scand.* 52 (1983), no. 2, 161–199.
- [88] M. Korkmaz, Automorphisms of complexes of curves on punctured spheres and on punctured tori, *Topology Appl.* 95 (1999), no. 2, 85–111.
- [89] G. Laget, *Groupes de Thompson projectifs de genre 0*, PhD Thesis, Univ. Grenoble I, 2004.

- [90] I. Liousse, Rotation numbers in Thompson-Stein groups and applications, *Geometriae Dedicata* 131(2008), 49–71.
- [91] P. Lochak, H. Nakamura et L. Schneps, On a new version of the Grothendieck-Teichmüller group, *C. R. Acad. Sci. Paris*, 325(1997), no. 1, 11–16.
- [92] P. Lochak et L. Schneps, The Grothendieck-Teichmüller group and automorphisms of braid groups. *The Grothendieck theory of dessins d'enfants* (Luminy, 1993), 323–358, London Math. Soc. Lecture Note Ser., 200, Cambridge Univ. Press, Cambridge, 1994.
- [93] P. Lochak et L. Schneps, The universal Ptolemy-Teichmüller groupoid, *Geometric Galois actions*, 2, 325–347, London Math. Soc. Lecture Notes Ser., 243, Cambridge, 1997.
- [94] I. Madsen and M. Weiss, The stable moduli space of Riemann surfaces: Mumford's conjecture, *Ann. of Math. (2)* 165 (2007), no. 3, 843–941.
- [95] I. Madsen, Homology of the open moduli space of curves, *Handbook of Teichmüller theory*, vol. III, EMS Publishing House, Zürich 2011.
- [96] I. Marin, On the representation theory of braid groups, preprint 2003-2005.
- [97] X. Martin, *Sur la Géométrie du Groupe de Thompson*, Thèse de Doctorat, Univ. Joseph Fourier (Grenoble I), juin 2002.
- [98] X. Martin, Piecewise-projective representation of Thompson's group  $T$ , *Geometric methods in group theory*, 161–180, Contemp. Math., 372, Amer. Math. Soc., Providence, RI, 2005.
- [99] F. Matucci, Shpilrain-Ushakov protocol for Thompson's group is always breakable, *J. of Cryptology* 213(2009), 458–468.
- [100] G. Moore and N. Seiberg, Classical and quantum field theory, *Commun. Math. Physics*, 123 (1989), 177–254.
- [101] S. Morita, Structure of the mapping class group and symplectic representation theory, *Essays on geometry and related topics*, (E. Ghys, P. De la Harpe, V. Jones, V. Sergiescu, Eds.) Vol. 2, 577–596, Monogr. Enseign. Math., 38, Genève, 2001.
- [102] A. Navas, *Groups of diffeomorphisms of the circle*, Chicago Lectures in Mathematics Series, Univ. of Chicago Press, 2011.
- [103] Yu. A. Neretin, Combinatorial analogues of the group of diffeomorphisms of the circle, *Russian Acad. Sci. Izv. Math.* 41 (1993), 337–349.
- [104] L. Mosher, Mapping class groups are automatic, *Ann. of Math. (2)* 142 (1995), 303–384.
- [105] T. Napier and M. Ramachandran, Thompson's group  $F$  is not Kähler, Topological and asymptotic aspects of group theory, 197–201, *Contemp. Math.*, 394, Amer. Math. Soc., Providence, RI, 2006.
- [106] G. A. Niblo and L. D. Reeves, The geometry of cube complexes and the complexity of their fundamental groups, *Topology* 37 (1998), 621–633.

- [107] C. Oikonomides, The Godbillon-Vey cyclic cocycle for PL foliations, *J. Funct. Analysis* 234 (2006), 127–151.
- [108] R. C. Penner, Universal constructions in Teichmüller theory, *Advances Math.* 98 (1993), 143–215.
- [109] R. C. Penner, The universal Ptolemy group and its completions, *Geometric Galois actions*, 2, 293–312, London Math. Soc. Lecture Notes Ser., 243, Cambridge, 1997.
- [110] A. Pressley et G. Segal, *Loop groups*, Oxford Mathematical Monographs. Oxford Science Publications. The Clarendon Press, Oxford University Press, New York, 1986.
- [111] A. Reznikov, Analytic topology of groups, spaces and strings, in *Geometry and dynamics of groups and spaces*, 3–92, Progress in Mathematics 265, 2008.
- [112] D. Ruinski, A. Shamir and B. Tsaban, Length-based cryptanalysis: the case of Thompson’s group, *J. Math. Cryptol.* 1 (2007), 309–372.
- [113] V. Sergiescu, *Graphes planaires et présentations des groupes de tresses*, *Math. Z.* 214 (1993), 477–490.
- [114] V. Sergiescu, Versions combinatoires de  $\text{Diff}(S^1)$ . Groupes de Thompson, Appendix B in L. Guieu and C. Roger, *L’algèbre et le groupe de Virasoro. Aspects géométriques et algébriques, généralisations*, Les Publications CRM, Montreal, QC, 2007.
- [115] R. J. Thompson, Embeddings into finitely generated simple groups which preserve the word problem, in *Word problems*, II (Conf. on Decision Problems in Algebra, Oxford, 1976), *Stud. Logic Foundations Math.* 95, North-Holland, Amsterdam 1980, 401–441.
- [116] U. Tillmann, On the homotopy of the stable mapping class group, *Invent. Math.* 130 (1997), no. 2, 257–275.
- [117] U. Tillmann, Higher genus surface operad detects infinite loop spaces, *Math. Ann.* 317 (2000), no. 3, 613–628.
- [118] A. Usnich, Symplectic automorphisms of  $\mathbb{C}P^2$  and the Thompson group  $T$ , arXiv:math/0611604.