

THE GRADED COBORDISM GROUP OF CODIMENSION-ONE IMMERSIONS

L. FUNAR AND R. GINI

Abstract

The cobordism group $N(M^n)$ of codimension-one immersions in the n -manifold M^n has a natural filtration induced by any cellular decomposition. The problem addressed in this paper is the explicit computation of the graded group $gr^*N(M^n)$. We introduce some new invariants for immersions enlightening the Atiyah–Hirzebruch spectral sequence associated to $N(M)$, which are of combinatorial-geometric nature. Explicit computations are developed for $n \leq 7$, and the group structure is also investigated for orientable 4-manifolds.

1 Introduction

The classification of manifold immersions in codimension at least one up to cobordism was reduced to a homotopy problem by the results of [V],[W]. These techniques are however awkward to apply if one wants to get effective results. The classification up to regular homotopy is also a homotopy problem which is closely related to the previous one. For instance two immersed surfaces in \mathbf{R}^3 of the same topological type are regularly homotopic if and only if they are cobordant (see [Pi]). This subject received recently more attention (see e.g. [N]).

The group P_n of codimension-one immersions in the n -sphere up to cobordism is the the n -th stable homotopy group of \mathbf{RP}^∞ and they were computed by Liulevicius ([L]) for $n \leq 9$. Explicit classifications for regular homotopy equivalence of immersed surfaces in 3-manifolds were first obtained by Hass and Hughes in [HH] and Pinkall (see [Pi]).

The cobordism group $N(M^3)$ of immersed surfaces in the 3-manifold M^3 was computed geometrically by Benedetti and Silhol ([BS]). Let M^3 be a compact oriented 3-manifold and f a smooth codimension-one immersion of a (compact) surface F^2 in M^3 . Fixing a Spin structure on M^3 one

has a Pin structure induced on F^2 which defines a $\mathbf{Z}/4\mathbf{Z}$ -valued quadratic form on $H_1(F^2, \mathbf{Z}/2\mathbf{Z})$, by counting how the immersion f twists the regular neighborhoods of 1-cycles in F^2 . There is then an isomorphism between $N(M^3)$ and $H_1(M^3, \mathbf{Z}/2\mathbf{Z}) \oplus H_2(M^3, \mathbf{Z}/2\mathbf{Z}) \oplus \mathbf{Z}/8\mathbf{Z}$, the last being endowed with a twisted product. The isomorphism sends an immersion f into the triple consisting of the homology class of the double points locus, the homology class of the image of f , and the Arf invariant of the quadratic form from above. A similar result holds for nonorientable 3-manifolds M^3 , but the factor $\mathbf{Z}/8\mathbf{Z}$ is replaced now by $\mathbf{Z}/2\mathbf{Z}$ (see [G2]). Notice that the factor $\mathbf{Z}/8\mathbf{Z}$ is nothing but $N(S^3)$ so the two results above can be stated in a unitary way by considering $H^3(M^3, \mathbf{Z}/8\mathbf{Z})$.

We would like to have a similar description for the group $N(M^n)$ in all dimensions n . More motivation for that is the result of [F], which relates the cobordism group $N(M^n)$ to the set $CB(M)$ of cubulations of the manifold M^n modulo a set of combinatorial moves analogous to Pachner's move on simplicial complexes. We refer to [F] for an extensive discussion of this problem, due to Habegger (see problem 5.13 from [K]).

We note first that there is a natural grading gr^* on $N(M^n)$ induced by a cellular decomposition. The Atiyah–Hirzebruch spectral sequence (see [Hi]) has its second term $E_2^{p,q} = H^q(M^n, P_p)$ and converges to the graded $N(M^n)$. However we have only very little information about the differentials in this sequence, hence the direct use of this approach fails. We develop then a combinatorial way to settle this question.

We obtain thus the extension of the computations of the graded group $gr^*N(M^n)$ up to dimension 4, and up to dimension 7 under a mild homological condition. However the techniques used are different from those of Benedetti and Silhol, although they are still geometric in nature.

The main theorem is the following:

Theorem 1.1. *Let M be a closed n -manifold, $n \leq 7$. Then*

$$gr^*(N(M)) = H^1(M, P_1) \times EH^2(M) \times H^3(M, P_3) \times \cdots \times H^n(M, P_n).$$

The subgroup $EH^2(M) \subseteq H^2(M, P_2)$ is defined in section 6.1 and is computed for any $n \leq 4$, and in some cases for $n \in \{5, 6, 7\}$, as follows:

$$EH^2(M) = \begin{cases} H^2(M, P_2) & \text{if } n \leq 3 \text{ or } n = 4 \text{ and} \\ & M \text{ non-orientable} \\ \{x \in H^2(M, P_2); x \cup x = 0\} & \text{if } n=4 \text{ and } M \text{ orientable or} \\ & n > 4 \text{ and condition } (*) \text{ holds} \end{cases}$$

where the condition $(*)$ for n -manifolds with $n \in \{5, 6, 7\}$ is that M is orientable and $\text{Ext}(H_3(M), \mathbf{Z}/8\mathbf{Z}) = 0$.

The whole theory is explicitly developed for closed manifolds. However the present methods can be applied to non-compact manifolds simply by substituting the ordinary cohomology with the cohomology with compact support.

A sketch of proof. We briefly summarize the guiding line of the paper. We introduce in section 3 the natural filtration of $N(M)$ that gives rise to the graded group, and prove that F^k can be interpreted geometrically as the subgroup of $N(M)$ of those immersions avoiding the k -skeleton up to cobordism. This property is independent of the cellular decomposition. In section 4 we define in a geometric way an injective homomorphism

$$\tilde{\chi}^k : F^k/F^{k+1} \longrightarrow H^k(M, P_k)/NEH^k(M),$$

where $NEH^k(M) \subseteq H^k(M, P_k)$ is a subgroup of cocycles related to some particular null-cobordant immersions. We then introduce an obstruction theory that permits to study the inverse map to $\tilde{\chi}^k$, in particular to determine its image. In section 6.1 the theory is applied to explicit computations that provide the image of $\tilde{\chi}^k$ up to $n = 7$, and in section 6.2 it is proven that $NEH^k(M) = 0$ for all k in all n -manifold M up to $n = 7$. These computations prove the main theorem.

Acknowledgements. We are indebted to Riccardo Benedetti, Octav Cornea, Takuji Kashiwabara, Valentin Poénaru, John Scott-Carter and Pierre Vogel for valuable discussions and suggestions. Part of this work was done when the first author visited Tokyo Institute of Technology, which he wishes to thank for support and hospitality, and especially to Teruaki Kitano and Tomoyoshi Yoshida.

2 The Groups P_n and Q_n in Low Dimension

Let M be a n -dimensional manifold. Consider the set of immersions $f : F \rightarrow M$ with F a closed $(n - 1)$ -manifold. Impose on it the following relation: (F, f) is *cobordant* to (F', f') if there exist a cobordism X between F and F' , that is, a compact n -manifold X with boundary $F \sqcup F'$, and an immersion $\Phi : X \rightarrow M \times I$, transverse to the boundary, such that $\Phi|_F = f \times \{0\}$ and $\Phi|_{F'} = f' \times \{1\}$.

Once the manifold M is fixed, the set $N(M)$ of cobordism classes of codimension-one immersions in M is an abelian group with the composition law given by disjoint union.

In this paper we mainly deal with the cobordism group of immersions in manifolds of dimension less or equal than 7. This is due to the fact that the

groups $P_n := N(S^n) = N(\mathbf{R}^n)$, which are always finite, 2-torsion groups (see [W]), are particularly simple for $n < 7$, as is shown in the following table (see [L]):

n	1	2	3	4	5	6	7	8	9
P_n	$\mathbf{Z}/2\mathbf{Z}$	$\mathbf{Z}/2\mathbf{Z}$	$\mathbf{Z}/8\mathbf{Z}$	$\mathbf{Z}/2\mathbf{Z}$	0	$\mathbf{Z}/2\mathbf{Z}$	$\mathbf{Z}/16\mathbf{Z} \oplus \mathbf{Z}/2\mathbf{Z}$	$(\mathbf{Z}/2\mathbf{Z})^{\oplus 3}$	$(\mathbf{Z}/2\mathbf{Z})^{\oplus 4}$

The simplest case is $n = 5$, but the cases $n = 1, 2, 4, 6$ are also very easy to handle. Indeed consider the classical invariant

$$\theta_n : P_n \longrightarrow \mathbf{Z}/2\mathbf{Z},$$

that associates to an immersion the number of n -tuple points modulo 2, or equivalently, the homology class modulo 2 of the set of n -tuple points (as an element of $H_0(S^n, \mathbf{Z}/2\mathbf{Z})$). It is well known that θ_n is an isomorphism for $n = 1, 2, 4, 6$ (see for example [C]). The group P_2 is generated by the immersion 8 which looks like the figure eight in the plane, while the group P_4 is generated by an immersion of S^3 with a single quadruple point.

By definition of cobordism an immersion f of a compact $(n-1)$ -manifold in S^n represents the trivial element of P_n if and only if there exists an immersion of a compact n -manifold with boundary in $S^n \times I$ transverse to the boundary. It is clear that this is equivalent to ask that f bounds in D^{n+1} . We generalize slightly this condition.

DEFINITION 2.1. *Denote by Q_n the subgroup of P_n of those immersions in S^n bounding an immersion of a compact n -manifold with boundary in a $(n+1)$ -manifold with boundary S^n .*

The reason why θ_n being an isomorphism makes computations easier also when dealing with immersions in manifolds that are not spheres amounts to the following easy proposition, lying on the elementary but fundamental fact that compact 1-manifolds with boundary have an even number of points as boundary.

PROPOSITION 2.2. *Let $f : F \rightarrow S^n$ be a a codimension-one immersion, and let n be such that either θ_n is an isomorphism or P_n is trivial. Then f bounds an immersion in a $(n+1)$ -manifold whose boundary is S^n if and only if it bounds in D^{n+1} , that is $Q_n = 0$.*

Proof. If n is such that $P_n = 0$ there is nothing to prove. Assume then that θ_n is an isomorphism and let f be a immersion in S^n . Suppose that there exists a $(n+1)$ -manifold N with boundary S^n and a generic codimension-one immersion g in N transverse to the boundary and such that $g \cap \partial N = f$. The set of n -tuple points of g is the immersion in N of a compact 1-manifold with boundary, bounding the set of n -tuple points of f . But a

1-manifold has an even number of points as boundary, so $\theta_n(f) = 0$, that is, f represents the trivial element of P_n . \square

This proposition does not apply, for example, for $n = 3$. The group $P_3 = \mathbf{Z}/8\mathbf{Z}$ is generated by the left Boy immersion, which has a single triple point. The even elements have no triple points. Canonical representatives for these classes are the immersions in \mathbf{R}^3 obtained by rotating an 8 on the xz plane with the double point in $(1, 0, 0)$ around the z axis, while rotating it in its own plane of half a twist, a whole twist and respectively three halves of twists (see [Pi]). These immersions, whose Arf invariants are 2, 4 and 6 respectively, have a circle of double points. The immersion similarly constructed that makes no rotations is null-cobordant.

From Proposition 2.2 it immediately follows:

COROLLARY 2.3. *For any n the group Q_n is contained in $\ker \theta_n$.*

In computing Q_3 we will make use first of a natural way of producing codimension-one immersions.

DEFINITION 2.4. Let N be a n -manifold (possibly with boundary) and S an embedded codimension- k submanifold. Assume that the structure group of the normal bundle ν to S in M can be reduced to the group of symmetries of an element $f \in P_k$, and choose such a reduction denoted by μ . There is then a canonical embedding of f in each fiber \mathbf{R}^k of ν giving rise to a sub-fibration of ν with fiber f . The total space of the last fibration is an immersion in the tubular neighborhood of S , hence in N , which will be called the *immersion obtained by decorating S with f* and will be denoted by $S \times_{\mu} f$ or by $S \times f$ if the reduction is not relevant to the context. The cobordism class of this immersion is clearly independent of the representative of the cobordism class of f , but might depend on μ .

For example, note that the symmetry group of the 8 in \mathbf{R}^2 is the same as the symmetry group of a line, so decorating a codimension-two submanifold with an 8 is the same as choosing a field of lines on the submanifold itself, if any. In particular the canonical representatives of the even elements of P_3 can be considered as $S^1 \times_{\mu_m} 8$, where S^1 is the standard circle in \mathbf{R}^3 and μ_m is the line field on the circle making m halves of twist, $m = 0, 1, 2, 3$, hence $\text{Arf}(S^1 \times_{\mu_m} 8) = 2m$. Note that in an orientable n -manifold any simple curve has trivial normal bundle, hence it can be decorated by any element of P_{n-1} , the cobordism class of the resulting immersion only depending on the choice of the trivialization. On the other hand, in a non-orientable n -manifold a simple curve non-trivially intersecting the orientation cycle

cannot be decorated by an element of P_{n-1} not admitting a reflection in its symmetry group.

PROPOSITION 2.5. $Q_3 = 2P_3$.

Proof. Let M be the non-orientable S^3 bundle on S^1 , let e^4 be a 4-ball in M intersecting S^1 and $N = M \setminus \text{int}(e^4)$. Let γ be $S^1 \setminus (\text{int}(e^4) \cap S^1)$. The normal bundle to γ is trivial hence one can decorate it with left Boy immersions. Denote by g the resulting immersion and by f its intersection with the three sphere ∂e^4 . Note that when seen in the boundary of e^4 (with any of its possible orientations) the two connected components of f have the same orientation: otherwise the whole of S^1 could be decorated by left Boy immersions, which is not possible since the Boy immersions do not admit reflections in their symmetry group. Hence f determines a non-trivial element of P_3 that has Arf invariant 2 or 6, according to the orientation one has chosen on ∂e^4 . But it is clear from its construction that f bounds in $N = M \setminus \text{int}(e^4)$. So f is in Q_3 and the same holds for the subgroup of P_3 it generates, that is, the whole of $2P_3$. \square

The proof of this proposition easily extends to the following statement:

PROPOSITION 2.6. *For any n one has $2P_n \subseteq Q_n$. Moreover any $f \in 2P_n$ bounds in any non-orientable $(n+1)$ -manifold with boundary S^n .* \square

Set then $\mathcal{P}_n = P_n/Q_n$ for the group of immersions in S^n up to cobordism in manifolds bounding two spheres. We proved the following:

n	1	2	3	4	5	6
\mathcal{P}_n	$\mathbf{Z}/2\mathbf{Z}$	$\mathbf{Z}/2\mathbf{Z}$	$\mathbf{Z}/2\mathbf{Z}$	$\mathbf{Z}/2\mathbf{Z}$	0	$\mathbf{Z}/2\mathbf{Z}$

REMARK 2.7. The immersion with invariant 4 bounds in an orientable 4-manifold. Indeed, let L be a sphere corresponding to a complex line in \mathbf{CP}^2 . There exists a normal vector field μ on L with a single zero. Let e^4 be a 4-ball containing this zero. The restricted normal field $\tilde{\mu}$ then trivializes the normal bundle to $L \setminus (L \cap e^4)$ in $N = \mathbf{CP}^2 \setminus \text{int}(e^4)$, so one can define the immersion $g := L \setminus (L \cap e^4) \times_{\tilde{\mu}} 8$. A straightforward computation shows that $f := g \cap \partial e^4$ is an immersion with Arf invariant 4, and clearly f bounds in the orientable manifold N .

3 A Natural Filtration of $N(M)$

The point of view from which we are able to tackle the computation of $N(M)$ is that of splitting it in pieces. At first sight the splitting depends on the cellular decomposition of M .

DEFINITION 3.1. Let M be a n -manifold and let

$$M_0 \subseteq \cdots \subseteq M_k \subseteq \cdots \subseteq M_n$$

be a skeleton decomposition. Let $F^k \subset N(M)$, for $k \geq 1$, be the set of immersions that up to cobordism do not intersect M_{k-1} . An immersion f whose class belongs to F^k will be said k -admissible if $f \cap M_{k-1} = \emptyset$.

Note that F^k is a subgroup of $N(M)$ hence one has a filtration of $N(M)$. One has

$$N(M) = F^0 \supseteq \cdots \supseteq F^k \supseteq \cdots \supseteq F^n,$$

where F^0 was added for convenience of notation. This filtration comes in fact in a natural way from the algebraic-topological definition of $N(M)$.

PROPOSITION 3.2. Under the Pontryagin–Thom construction we have

$$\begin{aligned} F^k &= \{ \varphi \in [M, Q\mathbf{RP}^\infty] \text{ such that } \varphi|_{M_{k-1}} \sim * \} \\ &= \ker ([M, Q\mathbf{RP}^\infty] \rightarrow [M_{k-1}, Q\mathbf{RP}^\infty]), \end{aligned}$$

where \sim means homotopy and $*$ is the trivial based loop.

Proof. If an immersion f does not intersect M_{k-1} then the map φ_f associated by the Pontryagin–Thom construction is constant on M_{k-1} . On the other hand, given a map φ that is null-homotopic when restricted to M_{k-1} , consider the homotopy

$$H : M_{k-1} \times I \longrightarrow Q\mathbf{RP}^\infty,$$

such that $H(-, 0) = \varphi|_{M_{k-1}}$ and $H(-, 1)$ is the constant map on M_{k-1} . The inclusion of the $(k-1)$ -skeleton being a cofibration implies (see [P]) that H extends to $M \times I$. Thus it gives a homotopy between φ and a map φ' defined on all of M , whose restriction to M_{k-1} is constant. Consider a closed regular neighborhood N of M_{k-1} in M . There exists then a global retraction $r : M \rightarrow M$ so that $r(N) = M_{k-1}$. The map $\varphi'' = \varphi' \circ r$ is thus constant on N (in particular on ∂N) and is homotopic to φ . Therefore the Thom–Pontryagin construction for the manifold with boundary $M - \text{int}(N)$ associates to the map $\varphi''|_{M \setminus \text{int}(N)}$ an immersion in $M \setminus \text{int}(N)$. When looking at that immersion as contained in M it results as a k -admissible representative of the class associated to φ , hence the claim is proved.

We give a second proof introducing a recursive technique that will be often exploited in the sequel. We assume that the cellular decomposition is in particular a cubulation. Recall that a *cubical complex* is a complex K consisting of Euclidean cubes, such that the intersection of two cubes is a finite union of cubes from K , once a cube is in K then all its faces belong to K , and no identifications of faces of the same cube are allowed. A

cubulation of a manifold is specified by a cubical complex PL homeomorphic to the manifold.

Consider a class with a representative immersion f for which the map φ_f defined by the Pontryagin–Thom construction belongs to $\ker(N(M^n) \rightarrow [M_{k-1}, \mathbf{QRP}^\infty])$. We want to deform f up to cobordism in such a way that the new representative does not intersect M_{k-1} . There exists a homotopy H of M so that the restriction of $\varphi_f \circ H|_{M_{k-1}}$ is null-homotopic. One uses now a recurrence on the degree k . If $k = 1$ then it is obvious since the immersion can miss the 0-skeleton by general position. Assume the claim is true for degree at most $k - 1$. Then there exists a representative immersion so that $f \cap M_{k-2}^n = \emptyset$. This means that the intersection $f \cap e^{k-1}$ with any $(k - 1)$ -cell is a closed immersed submanifold lying in the interior of the cell. By hypothesis we can assume that $\varphi_f|_{M_{k-1}} = 1$, where 1 denotes the constant (trivial) map. This means that $\varphi_f|_{e^{k-1}} = 1$. The Thom–Pontryagin theory implies that the immersion $f \cap e^{k-1}$ is null cobordant. Consider a small regular neighborhood V of e^k in M , which is a product $e^k \times B^{n-k}$. Since $f \cap e^{k-1}$ is null cobordant there exists an immersion g in $e^{k-1} \times I$ providing a null-cobordism for $f \cap e^{k-1}$. One uses $g \times \partial B^{n-k}$ to change the immersion in V so that the new immersion misses e^{k-1} . \square

Now it is a classical result that such a filtration is independent on the cellular decomposition. Indeed $[\cdot, \mathbf{QRP}^\infty]$ is the 0-th degree of the generalized cohomology theory associated to the suspension spectrum of \mathbf{QRP}^∞

$$h^q(X) = \lim_{n \rightarrow \infty} [\Sigma^n X, \Sigma^{n+q} \mathbf{RP}^\infty], \quad q \in \mathbf{Z},$$

and so the Atiyah–Hirzebruch spectral sequence converges to the graded group associated to the filtration of Proposition 3.2. The filtration being independent on the cellular decomposition for realizable generalized cohomology theories is then illustrated in the first and third chapter of the book of Hilton [Hi].

From now on we will often choose to use cubical decompositions of the manifold M . This will permit to perform recursive constructions in an easier way because a cubulation of M induces in an obvious way one for $M \times I$.

REMARK 3.3. Most of the analysis that follows, and notably the definition of cohomological invariants and the application of obstruction theory, does not make use of any specific property of the generalized cohomology theory of cobordism groups of immersions, except perhaps the fact that it has finite

coefficients. It is possible then that the same definitions apply usefully to other generalized cohomology theories.

4 Cohomological Invariants

Recall that a k -admissible immersion f is such that $f \cap M_{k-1} = \emptyset$. In particular for any k -cell e^k the intersection $f \cap e^k$ is contained in $\text{int}(e^k)$. If e^k is oriented then $f \cap e^k$ detects an element of P_k . One introduces then the following geometric definition. To any k -admissible immersion f there is associated a cochain $\chi_f^k \in C^k(M, P_k)$ the following way:

$$\chi_f^k(e^k) := f \cap e^k \in P_k.$$

PROPOSITION 4.1. *For k -admissible f the cochain χ_f^k is a cocycle.*

Proof. Given a $(k + 1)$ -cell e^{k+1} recall that $\delta\chi_f^k(e^{k+1}) = \chi_f^k(\partial e^{k+1})$ holds. Now denote $\partial e^{k+1} = \sum_{i \in \mathcal{I}(e^{k+1})} \varepsilon_i e_i^k$ where $\mathcal{I}(e^{k+1})$ is a finite set, e_i^k are oriented k -cells (not necessarily different from each other) and $\varepsilon_i = \pm 1$. Consider the cell as a closed $(k + 1)$ -disk attached to M_k by means of an attaching map, that results to be a homeomorphism when restricted to any connected component of the preimage of any e_i^k . Since $f \cap M_{k-1}$ is empty one can then pull back $f \cap e^{k+1}$ in the disk. The restriction of the resulting immersion to the boundary of the disk is then

$$\sum_{i \in \mathcal{I}(e^{k+1})} \varepsilon_i (f \cap e_i^k) = \sum_{i \in \mathcal{I}(e^{k+1})} \varepsilon_i \chi_f^k(e_i^k) \in N(S^k)$$

and is trivial since it bounds in the disk. But this is $\chi_f^k(\partial e^{k+1})$, hence χ_f^k is a cocycle. □

The argument of the previous proof will be repeatedly used. It is easy to visualize it when the cellular decomposition is a cubulation. For an immersion f and a $(k + 1)$ -cube e^{k+1} the intersection $f \cap e^{k+1}$ is a cobordism to the empty set of $f \cap \partial e^{k+1}$. Thus the last one is trivial as an element of P_k . When f is k -admissible $f \cap \partial e^{k+1}$ splits as the sum (with signs) of χ_f^k (faces).

Assume from now on that the cellular decomposition is a cubulation. It is easy to see that if f and f' are k -admissible immersions admitting a cobordism g , which does not intersect $M_{k-1} \times I$, then $\chi_f^k = \chi_{f'}^k$. In fact for any k -cube e^k the intersection $g \cap (e^k \times I)$ is a cobordism between $f \cap e^k$ and $f' \cap e^k$. The most natural question is whether f and f' admit a k -admissible cobordism, that is a cobordism not intersecting $M_{k-2} \times I$. This leads to the following result:

PROPOSITION 4.2. *Let f and f' be k -admissible cobordant immersions admitting a cobordism that is k -admissible in $M \times I$. Then χ_f^k and $\chi_{f'}^k$ are cohomologous.*

Proof. Assume f and f' transverse to the cubulation, and take a cobordism g between them that is transverse to the standard cubulation of $M \times I$ associated with the cubulation of M . Our aim is to define a coboundary between χ_f^k and $\chi_{f'}^k$, by means of the same definition we used for χ^k , but now applied to g . Note that for any k -cube e^k the intersection $g \cap (e^k \times I)$ is a cobordism to the empty set of $g \cap \partial(e^k \times I)$, thus the last one is then a trivial element in P_k . Since g is k -admissible this element splits as the sum of $f \cap e^k - f' \cap e^k = \chi_f^k - \chi_{f'}^k$, and of $g \cap (\partial e^k \times I)$, see Figure 1. We claim

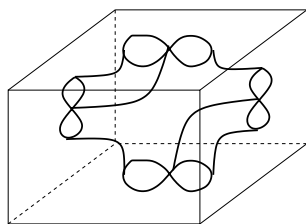

Figure 1: A k -admissible immersion restricted to a $(k + 1)$ -cube

that the last summand is the coboundary of a $(k - 1)$ -cochain of M .

Define a cochain ψ in $C^{k-1}(M, P_k)$ this way. For any oriented $(k - 1)$ -cell e^{k-1} consider the class of the immersion $g \cap (e^{k-1} \times I)$ where the orientation of $e^{k-1} \times I$ is such that it induces on e^{k-1} the opposite of its orientation. With this convention $g \cap (e^{k-1} \times I)$ is a well-defined element of P_k .

It is then easy to see that $\delta\psi(e^k) = g \cap (\partial e^k \times I)$, hence $\delta\psi = \chi_{f'}^k - \chi_f^k$. \square

It is immediate that two cobordant immersions which are 1-admissible have a 1-admissible cobordism between them. For general k we are not able to prove the analogous statement. We will face this problem gradually. If g is a generic cobordism between k -admissible immersions, and e^s is an s -cube of M we denote by $g(e^s)$ the immersion $g \cap (e^s \times I)$, where the orientation of $e^s \times I$ is such that it induces on e^s the opposite of its orientation. Now if g is s -admissible then $g(e^s)$ is actually an immersion in the open $(s + 1)$ -disk $\text{int}(e^s) \times (0, 1)$, hence $g(e^s)$ represents an element of P_{s+1} . Further if $g(e^{k-2})$ is empty for any $(k - 2)$ -cube then g is k -admissible.

PROPOSITION 4.3. *Let f and f' be 2-admissible cobordant immersions. Then there exists a 2-admissible cobordism between them.*

Proof. Let g be a generic cobordism between f and f' , transverse to the cubulation of $M \times I$ associated to a chosen cubulation of M . We want to prove that we can deform g until $g(e^0) = \emptyset$ for any e^0 .

Note that $g(e^0)$ represents an element of P_1 . We claim that, up to modify g if M is compact, this element is trivial for any e^0 . First note that if e^0 and f^0 are two vertices of the cubulations that are connected by an edge e^1 , then $g(e^0)$ and $g(f^0)$ are the same element of P_1 . This is because $g(e^1)$ provides a cobordism between them and this proves in fact, M being connected, that there is a well-defined $g^0 \in P_1$ such that $g(e^0) = g^0$ for any vertex e^0 of M . Now suppose M is not compact. Since the domain of g is compact its image cannot intersect all edges of the type $e^0 \times I$, hence g^0 is the trivial element of P_1 , and the claim is proved in this case. If M is compact, then g^0 might be non-trivial. But then consider a new cobordism obtained by adding a $M \times \{t\}$ to g . Call g the new cobordism and now g^0 is trivial as required.

So we are ready to get rid of intersections of type $g(e^0)$. For any vertex e^0 there is a diffeomorphism of a neighborhood $U(e^0) \times I$ with $B^n \times I$ such that $g \cap D^n \times I$ is the inclusion of an even number of disks at levels p_1, \dots, p_{2n} , since g can be assumed to be transverse to $e^0 \times I$. In this model cut the corresponding disks of radius $1/2$, and connect the holes in pairs by means of cylinders $\frac{1}{2}S^{n-1} \times [p_{2i-1}, p_{2i}]$. The immersion obtained by repeating this construction in any vertex and then smoothing, that we still call g , satisfies $g(e^0) = \emptyset$ for any vertex e^0 , hence g is 2-admissible. \square

In general, given a s -admissible cobordism g the elements $g(e^{s-1})$ for $s > 1$ might be nontrivial. If they are trivial however it is possible to deform g to a $(s + 1)$ -admissible cobordism. Consider the standard cubulation of $M \times I$ associated to a cubulation of M . We will say that cubes of the form $e \times I$ are *vertical*, cubes of the form $e \times \{0\}$ are *at the bottom* and cubes of the form $e \times \{1\}$ are *at the top*. In general cubes of the form $e \times \{t\}$ are *horizontal*.

LEMMA 4.4. *Let f and f' be $(s + 1)$ -admissible immersions, let g be a cobordism between them that is s -admissible and such that for any $(s - 1)$ -cell e^{s-1} of M the immersion $g(e^{s-1})$ represents a trivial element of P_s . Then g can be deformed to a $(s + 1)$ -admissible cobordism g' .*

If g is a s -admissible cobordism between f and f' , but f alone is $(s + 1)$ -admissible, then g can be modified to a $(s + 1)$ -admissible cobordism g' between f and an immersion coinciding with f' outside a neighborhood of M_s .

Proof. By a construction analogous to that of Proposition 4.3 it is possible to get rid of intersections. We again consider a model, as follows: the normal bundle to e^{s-1} in M is trivial, take a trivialized neighborhood $U(e^{s-1}) = e^{s-1} \times B^{n-s+1}$ and take its product with the interval I . From transversality one can suppose that $g \cap U(e^{s-1}) \times I$ has the structure of a product $g(e^{s-1}) \times B^{n-s+1}$. Consider a cobordism to the empty set of $g(e^{s-1})$, let h be the embedding of this cobordism in $e^{s-1} \times \frac{1}{4}B^1 \times I \subset U(e^{s-1}) \times I$ and take the product $h \times \frac{1}{2}S^{n-s-1}$. Note that the image of this product does not intersect $e^{s-1} \times I$, and that it intersects g in $g(e^{s-1}) \times \frac{1}{2}S^{n-s}$. Thus one can excise $g(e^{s-1}) \times \frac{1}{2}B^{n-s+1}$ and glue back $h \times \frac{1}{2}S^{n-s}$. After repeating this construction for any $(s-1)$ -cube and smoothing one gets a cobordism g' between f and f' satisfying $g'(e^{s-1}) = \emptyset$ for any e^s .

If f and f' are both $(s+1)$ -admissible then g is clearly $(s+1)$ -admissible, since the s -skeleton of $M \times I$ are the vertical $e^{s-1} \times I$ plus the two horizontal copies of M_s .

If f is $(s+1)$ -admissible, but f' intersects the s -skeleton, then we deform g' further. Note that for any s -cube e^s of M the cobordism $g' \cap (e^s \times I)$ is a cobordism to the empty set for $f' \cap e^s$. Hence this last immersion represents the trivial element of P_s . Then a surgery similar to the one of the first part of the proof leads to the excision of all of the intersections $g' \cap (e^s \times \{1\})$, and this proves the claim. \square

Since we cannot claim than any null-cobordant k -admissible immersion admits a k -admissible cobordism to the empty set, we introduce the following definition.

DEFINITION 4.5. Set $NEH^k(M)$ for the subset of $H^k(M, P_k)$ of those cohomology classes represented by some k -admissible null-cobordant immersions.

LEMMA 4.6. $NEH^k(M)$ is a subgroup of $H^k(M, P_k)$.

Proof. Given α and β cohomology classes represented by k -admissible null-cobordant immersions it is obvious that $\alpha + \beta$ is represented the same way.

As for $-\alpha$, let f be a k -admissible immersion such that $\chi_f^k = \alpha$, and let g be a cobordism to the empty set of f . Let g' be the cobordism between f in $M \times \{1\}$ and the empty set in $M \times \{0\}$ obtained by composing g with the reflection of I given by $t \mapsto 1 - t$. In a single $e^k \times I$ consider the following construction. Put a representative immersion of $-\alpha(e^k)$ in $e^k \times \{0\}$, put in $e^k \times \{1/3\}$ the same representative plus two copies of $f \cap e^k$ slightly

isotoped, and in $e^k \times \{2/3\}$ a single copy of $f \cap e^k$. Then fill $e^k \times [1, 1/3]$ with $-\alpha(e^k) \times [1, 1/3]$ plus two copies of $g' \cap (e^k \times I)$ rescaled to $1/3$, fill $e^k \times [1/3, 2/3]$ with a cobordism between $-\alpha(e^k)$ plus a copy of $f \cap e^k$ and the empty set and with $f \cap e^k \times [1/3, 2/3]$, and finally fill $e^k \times [2/3, 1]$ with $g' \cap (e^k \times I)$ (rescaled to $1/3$). Note that this immersion is not a cobordism between $-\alpha(e^k)$ and $\alpha(e^k)$, since g and g' possibly intersect $(\partial e^k) \times I$. Now note that the collection of immersions so defined glue together to a cobordism in $M_k \times I$, that restricted to $M_k \times \{0\}$ represents $-\alpha$. Consider on $M \times \{1\}$ the empty immersion and in $M_k \times I$ the collection of immersions defined before. This cobordism can be completed by Lemma 4.7 to a cobordism \tilde{g} between an immersion $\tilde{f} = \tilde{g} \cap (M \times \{0\})$ representing $-\alpha$ and the empty set, hence $-\alpha \in NEH^k(M)$. \square

The following lemma, that provides the technical step of the previous proof, will be repeatedly used in this section. It is an easy algebraic-topological argument, that has however an important geometric interpretation.

LEMMA 4.7. *An immersion g traced in $M \times \{0\} \cup M_s \times I$ extends to an immersion traced in the whole of $M \times I$. Moreover if g is l -admissible, for $l \leq s$, the extension is still l -admissible.*

Proof. If we see an immersion traced in $M \times \{0\} \cup M_s \times I$ as a continuous map from $M \times \{0\} \cup M_s \times I$ to $Q\mathbf{RP}^\infty$ this immediately follows from the fact that (M, M_s) is a cofibration. This construction has however an easy geometrical interpretation, see Figure 2. Consider a $(s + 1)$ -cube e^{s+1} . We want to extend the immersion traced on $g \cap (e^{s+1} \times \{0\} \cup \partial e^{s+1} \times I)$ to $e^{s+1} \times I$. First note that the resulting immersion on the boundary of the cube at the top is null-cobordant, since it bounds in the disk $e^{s+1} \times \{0\} \cup \partial e^{s+1} \times I$, hence a null-cobordism can be traced on the cube at the top. The resulting immersion in $\partial(e^{s+1} \times I)$ represents an element of P_{s+1} . Up to adding (in the interior of the cube at the top) another immersion we can assume this element is trivial, hence g can be extended to the interior of $e^{s+1} \times I$. Recursively g is extended to $M \times I$.

The second statement follows obviously from the construction. \square

We prove that χ^k is a well-defined invariant in the group $\frac{H^k(M, P_k)}{NEH^k(M)}$.

PROPOSITION 4.8. *Let f and f' be k -admissible cobordant immersions. Then $\chi_f^k - \chi_{f'}^k$ represents an element in $NEH^k(M)$, hence χ^k is a well-defined cobordism invariant in the group $H^k(M, P_k)/NEH^k(M)$.*

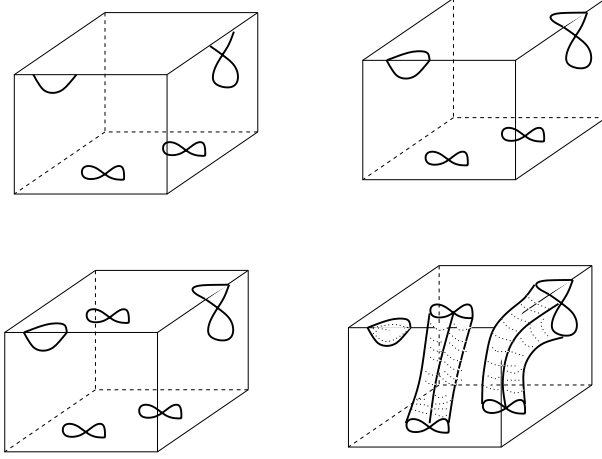

Figure 2: Extending an immersion to the interior of a cube with a free face

Proof. The technical step is to modify g , far from $M \times \{0\}$, in such a way that it doesn't intersect $M_{k-2} \times I$. This is only possible, in general, up to modifying $g \cap M \times \{1\}$. By Proposition 4.3 we might assume that g is 2-admissible. Assume by a recurrence hypothesis that g is a s -admissible cobordism between f and $f' + f_0$, where f_0 is a (null-cobordant) s -admissible immersion.

We want to deform g in such a way that $g(e^{s-1})$ becomes trivial for any e^s , in order to apply Lemma 4.4. We build up an auxiliary immersion \tilde{g}_s in $M \times I$. On the vertical cells $e^{s-1} \times I$ put a copy $g(e^{s-1})$, and on the bottom cells $e^j \times \{0\}$ fix the empty immersion for any j . Consider then the resulting collection of immersions as an immersion in $M \times \{0\} \cup M_{s-1} \times I$ and extend it to a cobordism \tilde{g}_s by means of Lemma 4.7. Then \tilde{g}_s satisfies the following properties:

$$\begin{aligned}\tilde{g}_s(e^{s-1}) &= g(e^{s-1}), \\ \tilde{g}_s \cap M \times \{0\} &= \emptyset, \\ \tilde{g}_s \cap M_{s-2} \times I &= \emptyset.\end{aligned}$$

Note now that there exists an integer a (the order of P_s minus 1) such that $g + a\tilde{g}_s$ has the property that $(g + a\tilde{g}_s)(e^{s-1})$ is trivial for any e^{s-1} . Call again g this cobordism and apply Lemma 4.4. The resulting cobordism g' between f and $g' \cap M \times \{1\}$ is then $(s+1)$ -admissible, and $g' \cap M \times \{1\}$ is of the form $f' + f'_0$ where f'_0 is (null-cobordant and) $(s+1)$ -admissible.

Repeat this construction until $s = k - 1$ and the resulting k -admissible cobordism, that we again call g , is such that

$$g \cap M \times \{1\} = f' + f_0,$$

where f_0 is (null-cobordant and) k -admissible. Then by Proposition 4.2 $\chi_{f'+f_0}^k$ differs from χ_f^k by a coboundary. But since

$$\chi_{f'+f_0}^k = \chi_{f'}^k + \chi_{f_0}^k,$$

one gets the claim. □

The invariant

$$\chi^k : F^k \longrightarrow \frac{H^k(M, P_k)}{NEH^k(M)},$$

defined by these propositions will be called the k -th cohomological invariant.

Note that if f is actually in F^{k+1} then χ_f^k is trivial, hence we are left with a well-defined homomorphism from F^k/F^{k+1} to $H^k(M, P_k)/NEH^k(M)$. This homomorphism is in fact injective.

PROPOSITION 4.9. *Let M be an n -manifold. For any $k = 1, \dots, n$ the kernel of the k -th cohomological invariant is F^{k+1} .*

Proof. Fix a cubulation in M . Let f be a k -admissible immersion such that $\chi_f^k = 0 \in H^k(M, P_k)$. This means there is an element $\gamma \in C^{k-1}(M, P_k)$ such that $\delta\gamma = \chi_f^k$. One builds up a cobordism g between f and a $(k + 1)$ -admissible immersion.

Consider the standard cubulation of $M \times I$ associated to the given cubulation of M . Put f in the bottom $M \times \{0\}$. For any $(k - 1)$ -cell of M , say e^{k-1} , put in the vertical cell $e^{k-1} \times I$ (with the orientation that induces on e^{k-1} the opposite of its orientation) the element $\gamma(e^{k-1}) \in P_k$. One fixes also the cobordism on the top $M_k \times \{1\}$. Consider a k -cell e^k of M . One defines the cobordism on $e^k \times I$ by noting that (from the definition of γ) the union of all immersions already defined in $\partial(e^k \times I)$ is null-cobordant. One can choose therefore a cobordism to the empty set. This can be done recursively on the whole of $M_k \times I$. Note that the resulting immersion g does not intersect $M_k \times \{1\}$.

Now g is defined on $M \times \{0\} \cup M_k \times I$, and applying Lemma 4.7 gives rise to a cobordism g in $M \times I$, that provides a cobordism between f and $g \cap (M \times \{1\})$; and this last does not intersect the k -skeleton, by construction.

A similar construction can be performed if $\chi_f^k \in NEH^k(M)$. Let f_0 be a null-cobordant map such that $\chi_{f_0}^k \sim \chi_f^k$. Put f in the whole bottom $M \times \{0\}$, $f_0 \cap M_k$ in the intermediate $M_k \times \{1/2\}$ and trace on the vertical

$M_k \times [1/2, 1]$ the intersection of a cobordism to the empty set of f_0 . The $(k-1)$ -cochain that cobounds $\chi_{f_0}^k$ and χ_f^k provides as before a cobordism between $f \cap M_k$ and $f_0 \cap M_k$, which we put in the vertical $M_k \times [0, 1/2]$. Over all this is a cobordism between $f \cap M_k$ and the empty set and so it can be extended by Lemma 4.7 to a cobordism g between f and a map $g \cap (M \times \{1\})$. By construction the last one does not intersect the k -skeleton. \square

COROLLARY 4.10. *Let M be an n -manifold. For any $k = 1, \dots, n$ the induced homomorphism*

$$\tilde{\chi}^k : \frac{F^k}{F^{k+1}} \longrightarrow \frac{H^k(M, P^k)}{NEH^k(M)},$$

is injective.

This corollary shows that the power of these new invariants is considerable. Indeed they describe the *graded group of $N(M)$ associated to the filtration*

$$gr(N(M)) = F^1/F^2 \times \dots \times F^{n-1}/F^n \times F^n,$$

as a subgroup of $H^1(M, P_1)/NEH^1(M) \times \dots \times H^n(M, P_n)/NEH^n(M)$, that is:

Theorem 4.11. *The cohomological invariants induce an injective homomorphism*

$$\tilde{\chi} : gr(N(M)) \longrightarrow H^1(M, P_1)/NEH^1(M) \times \dots \times H^n(M, P_n)/NEH^n(M).$$

\square

We end this section with an important remark. The cohomological invariants reduce, under suitable hypothesis, to the restriction of James–Hopf invariants. These are classical cobordism invariants, see [J] and [KoS].

DEFINITION 4.12. Let M be a n -manifold and (F, f) a generic codimension-one immersion. For $i = 1, \dots, n$ consider the locus of $(n-i)$ -tuple points of f , that is, the points of M that have a number of preimages equal to or larger than $n-i$. This set is in fact a i -cycle modulo 2, whose homology class is invariant up to cobordism. We denote $JH_i(f) \in H_i(M, \mathbf{Z}/2\mathbf{Z})$ this class and call it *i -th James–Hopf invariant*.

These invariants are particularly meaningful for those k such that P_k is non-trivial. For example given a codimension- k embedded submanifold S of an n -manifold M such that its normal bundle is reducible to the symmetry group of an element $f \in P_k$ satisfying $\theta_k(f) \neq 0$ then the following holds

$$JH_i(S \times f) = \begin{cases} [S] \in H_{n-k}(M, \mathbf{Z}/2\mathbf{Z}) & \text{if } i = n - k \\ 0 & \text{otherwise.} \end{cases}$$

PROPOSITION 4.13. *Assume that k is such that $\theta_k : P_k \rightarrow \mathbf{Z}/2\mathbf{Z}$ is the reduction modulo 2 of P_k . Then for any n -manifold the $(n-k)$ -th James–Hopf invariant restricted to F^k is the Poincaré dual to the reduction modulo 2 of χ^k .*

Proof. Let f be a k -admissible immersion generic and transverse to the decomposition of M . We denote by PD the Poincaré duality isomorphism. Then for any k -cell e^k of M the number $PD(JH_{n-k}(e^k))$ is the number of k -tuple points of $f \cap e^k$, modulo 2, hence, by the hypothesis on k , is the reduction modulo 2 of $f \cap e^k$ as an element of P_k , that is $\theta_k(\chi_f^k(e^k))$. The following diagram then commutes:

$$\begin{array}{ccc}
 F^k & \xrightarrow{\chi_k} & H^k(M, P_k) \\
 \downarrow JH_{n-k}|_{F^k} & & \searrow \theta_k^* \\
 H_{n-k}(M, \mathbf{Z}/2\mathbf{Z}) & & \\
 \downarrow PD & & \\
 H^k(M, \mathbf{Z}/2\mathbf{Z}) & &
 \end{array}$$

and since θ_k^* is reduction modulo 2 in cohomology the claim follows. \square

This proves at once the following:

PROPOSITION 4.14. *If k is such that θ_k is an isomorphism then $NEH^k(M) = 0$.* \square

5 Obstruction Theory

A more detailed study of the groups $NEH^k(M)$ is in order. From Proposition 4.3 and Lemma 4.4 one might guess that the vanishing of $NEH^k(M)$ is correlated with constructions that make the intersections $g(e)$ of a cobordism g with the vertical walls of $M \times I$ null-cobordant. This was made possible for example in the proof of Proposition 4.8 by means of the construction of an auxiliary immersion \tilde{g} with prescribed image on $M \times \{0\} \cup M_{s-1} \times I$. As we saw the possibility of obtaining such an auxiliary immersion amounts, at an accurate analysis, to the fact that (M, M_{s-1}) is a cofibration. However in order to leave the image of g fixed also in $M \times \{1\}$ we need a more delicate construction, that will be developed in section 5 and applied in section 6.2.

A second obvious motivation for developing this theory is the computation of the image of χ^k , that is, the subgroup of cohomology classes that

are represented by an immersion.

In this section we describe the general obstructions for a cochain in $C^k(M, P_k)$ to be realizable as an immersion. The basic idea is a recursive construction. Given $\xi \in C^k(M, P_k)$ we first put in the interior of every k -cube an immersion representing $\xi(e^k) \in P_k$, then try to extend this codimension-one immersion in M_k to a codimension-one immersion in M_{k+1} . This will be called the *first extendibility*. If this construction can be repeated until the n -th skeleton, i.e. the immersion can be further extended to a *second extension*, and so on then the original cochain is said to be *realizable* or *extendible*. If one can reach the s -th stage one says that the cochain is *s-extendible*.

We adapt to this context Eilenberg's obstruction theory, see [Wh, §V.5]. A cochain in $C^k(M, P_k)$ can be thought of as a map φ_k defined from M_k to \mathcal{QRP}^∞ , that restricted to any k -cell is geometrically represented by an element of P_k . The problem to which we apply Eilenberg's theory is that of extending this map over the next skeleton.

5.1 A review of obstruction theory. Given a s -simple space Y , a CW-complex X and a map $\varphi : X_s \rightarrow Y$ the *obstruction to extending φ to the $(s+1)$ -skeleton* is a cochain $c^{s+1}(\varphi) \in C^{s+1}(X, \pi_s(Y))$, assigning to each $(s+1)$ -cell e^{s+1} the map $\varphi|_{\partial e^{s+1}}$. Its fundamental properties are stated in the following theorem (see [Wh, §V.5]):

Theorem 5.1. 1. φ is extendible to X_{s+1} if and only if $c^{s+1}(\varphi)$ is the trivial cochain.

2. $c^{s+1}(\varphi)$ is a cocycle, hence represents an element of $H^{s+1}(X, \pi_s(Y))$.

3. $\varphi|_{X_{s-1}}$ is extendible to X_{s+1} if and only if $c^{s+1}(\varphi)$ is trivial in $H^{s+1}(X, \pi_s(Y))$.

The problem of further extending φ is codified in a sequence of obstruction maps. However for any extension there exists an obstruction cocycle, hence the obstruction to further extend $\varphi|_{X_{s-1}}$ becomes a set of cohomology classes. Assume that it is extendible to the $(s+l-1)$ -th skeleton, and let $\mathcal{O}^{s+l}(\varphi)$ be the set of cohomology classes given by

$$\mathcal{O}^{s+l}(\varphi) := \{c^{s+l}(\varphi_{s+l-1}) \mid \varphi_{s+l-1} \text{ is an extension of } \varphi|_{X_{s-1}} \text{ to the } (s+l-1)\text{-th skeleton}\} \subset H^{s+l}(X, \pi_{s+l-1}(Y)).$$

Theorem 5.2. Assume the map $\varphi|_{X_{s-1}}$ is extendible to the $(s+l-1)$ -skeleton. Then it is extendible to the $(s+l)$ -skeleton if and only if the 0 class belongs to $\mathcal{O}^{s+l}(\varphi)$.

5.2 Geometrical interpretation. We first recall that

$$[S^s, \mathbf{QRP}^\infty] = P_s,$$

hence the theory applies directly with coefficients in the groups P_s .

A k -cochain $\xi \in C^k(M, P_k)$ is fixed and we consider it to be a map defined on M_k taking values on \mathbf{QRP}^∞ . Consider then the obstruction

$$\begin{aligned} c^{k+1}(\xi) : C_{k+1}(M) &\longrightarrow \pi_k(\mathbf{QRP}^\infty), \\ e^{k+1} &\longmapsto \xi(\partial e^{k+1}), \end{aligned}$$

and note that, since $\pi_k(\mathbf{QRP}^\infty) = P_k$, the obstruction c^{k+1} is nothing but the ordinary coboundary of cochains with coefficients in P_k . Hence by property 1 of Theorem 5.1 it follows that:

PROPOSITION 5.3. *ξ is 1-extendible if and only if it is a cocycle.*

REMARK 5.4. This condition has the geometrical interpretation that was already illustrated in Figure 1.

Define now \mathcal{O}_k^{k+l} , for $l \geq 2$, to be the map that associates to $\xi \in H^k(M, P_k)$ the set $\mathcal{O}^{k+l}(\varphi_\xi) \subset H^{k+l}(X, P_{k+l-1})$, φ_ξ being any extension of ξ to the $(k+1)$ -skeleton, and define $\ker \mathcal{O}_k^s$ to be the subset of $H^k(M, P_k)$ of cocycles ξ such that $\mathcal{O}^s(\varphi_\xi)$ contains the trivial element of $H^s(X, P_{s-1})$. Note that $\ker \mathcal{O}_k^{s-1} \subseteq \ker \mathcal{O}_k^s$, and that \mathcal{O}_k^s is in fact only defined on $\ker \mathcal{O}_k^{s-1}$. From Theorem 5.2 one obtains the following proposition:

PROPOSITION 5.5. *$\xi \in H^k(M, P_k)$ is l -extendible if and only if it belongs to $\ker \mathcal{O}_k^{k+l}$. In particular it is realizable if and only if it belongs to $\ker \mathcal{O}_k^n$. \square*

Denote by $EH^k(M)$ the subgroup of $H^k(M, P_k)$ of extendible cocycles. Proposition 5.5 translates into:

$$EH^k(M) = \ker \mathcal{O}_k^n.$$

PROPOSITION 5.6. *Let $\xi \in EH^k(M)$; then the immersion f_ξ realizing ξ is a well-defined element in F^k/F^{k+1} .*

Proof. This follows from Proposition 4.9. If f' and f both realize ξ in particular they have the same k -th cohomological invariant $[\xi] \in \frac{EH^k(M)}{NEH^k(M)}$, so they differ by an element of F^{k+1} . \square

6 Explicit Computations

We apply the obstruction theory to the computation of both $EH^k(M)$ and $NEH^k(M)$ (the subgroup of $EH^k(M)$ of *null-extendible cocycles* cocycles realizable as a null-cobordant k -admissible immersion). The computations prove Theorem 1.1.

6.1 Extendible cocycles. The results are summarized in the following table, where $N^k := H^k(M, P_k)/EH^k(M)$ denotes the *non-extendible cocycles*.

dim M	orientability	N^1	N^2	N^3	N^4	N^5	N^6	N^7
2	both	0	0
3	both	0	0	0
4	orientable	0	$H^2(M, \mathbf{Z}/2\mathbf{Z})/Q^2(M, \mathbf{Z}/2\mathbf{Z})$	0	0	.	.	.
4	non-orientable	0	0	0	0	.	.	.
5	both	0	$H^2(M, \mathbf{Z}/2\mathbf{Z})/Q^2(M, \mathbf{Z}/2\mathbf{Z})^{(*)}$	0	0	0	.	.
6	both	0	$H^2(M, \mathbf{Z}/2\mathbf{Z})/Q^2(M, \mathbf{Z}/2\mathbf{Z})^{(*)}$	0	0	0	0	.
7	both	0	$H^2(M, \mathbf{Z}/2\mathbf{Z})/Q^2(M, \mathbf{Z}/2\mathbf{Z})^{(*)}$	0	0	0	0	0

(*) Under the condition M orientable and $\text{Ext}(H_3(M, \mathbf{Z}), \mathbf{Z}/8\mathbf{Z}) = 0$.

In this table $Q^2(M, \mathbf{Z}/2\mathbf{Z})$ denotes the subgroup of $H^2(M, \mathbf{Z}/2\mathbf{Z})$ defined by

$$Q^2(M, \mathbf{Z}/2\mathbf{Z}) = \{x \in H^2(M, \mathbf{Z}/2\mathbf{Z}); x \cup x = 0\}.$$

Note that, if M is a manifold, this is the quadric of $H^2(M, \mathbf{Z}/2\mathbf{Z})$ associated with the intersection form. Moreover for any dimension n one has:

dim M	orientability	N^1	N^s	N^{n-1}	N^n
n	both	0	?	0	0

We first prove the results from the last table.

PROPOSITION 6.1. *For any dimension n and for any n -manifold M*

$$EH^1(M) = H^1(M, P_1) = H^1(M, \mathbf{Z}/2\mathbf{Z}),$$

$$EH^{n-1}(M) = H^{n-1}(M, P_{n-1}),$$

$$EH^n(M) = H^n(M, P_n) = \begin{cases} P_n, & \text{if } M \text{ is orientable,} \\ P_n/2P_n, & \text{if } M \text{ is non-orientable.} \end{cases}$$

Proof. Since $P_1 = \mathbf{Z}/2\mathbf{Z}$ one can use Poincaré duality with coefficients P_1 in both orientable and non-orientable context. Now represent the Poincaré dual to ξ by an embedding and note that this embedding realizes ξ . That n and $(n-1)$ -cohomology classes extend follows immediately from obstruction theory. \square

REMARK 6.2. This result can be interpreted geometrically. That every n -class is extendible follows easily from the fact that taking a representative cocycle ξ a putting in any n -cube e^n an immersion representing $\xi(e^n)$ already realizes the cocycle.

Now let M be an orientable n -manifold, let ξ be a cohomology class in $H^{n-1}(M, P_{n-1})$, and consider its Poincaré dual $PD(\xi)$. By the universal coefficient theorem $PD(\xi)$ can be thought of as an element of $H_1(M, \mathbf{Z}) \otimes P_{n-1}$,

hence as a combination of the type $\sum \gamma_i \otimes f_i$ with $\gamma_i \in H_1(M, \mathbf{Z})$ and $f_i \in P_{n-1}$. To each $\gamma_i \otimes f_i$ we associate the following immersion. Take a simple closed loop representing γ_i . By decorating γ_i with f_i , which is always possible since the normal bundle of γ_i is trivial, one obtains an immersion realizing the Poincaré dual of $\gamma_i \otimes f_i$. Obviously the sum of such immersions realizes ξ .

Let n be such that P_{n-1} is either trivial or $\mathbf{Z}/2\mathbf{Z}$. Then if M is a non-orientable n -manifold the same construction applies. Indeed, these conditions on P_{n-1} both mean that any immersion in \mathbf{R}^{n-1} (up to a cobordism) admits a reflection in its symmetry group, since $f = -f$. Hence this construction applies, since also curves with non-orientable normal bundle can be always decorated with immersions in P_{n-1} .

We are ready now to prove the results from the main table. Let us first concentrate on codimension-two cocycles. If $k = n - 2$ there is only one obstruction, namely \mathcal{O}_{n-2}^n . This lives in the cyclic group $H^n(M, P_n)$. We now describe $\mathcal{O}_{n-2}^n(\xi)$ explicitly as an element of P_n or of $P_n/2P_n$, depending on M being orientable or not.

LEMMA 6.3. *Let M be any n -manifold. Every $\xi \in H^{n-2}(M, P_{n-2})$ is extendible to an immersion defined in $M \setminus \text{int}(e^n)$, where e^n is an n -ball.*

Proof. Perform a first extension f of ξ to M_{n-1} . Note that $M \setminus \text{int}(e^n)$ collapses simplicially on a subset S_{n-1} of M_{n-1} . Fix a way of building up $M \setminus \text{int}(e^n)$ from this subset, that is, order the set of n -cells in such a way that $e_{(1)}^n$ is attached to S_{n-1} and $e_{(i)}^n$ is attached to $S_{n-1} \cup \bigcup_{j=1}^{i-1} e_{(j)}^n$. For any i call the *free face* of $e_{(i)}^n$ the one to which a cell of M will be attached first. Note that every n -cell but e^n has a free face. When attaching the first n -cell $e_{(1)}^n$ extend the immersion $f \cap \partial e_{(1)}^n$ this way. If $f \cap \partial e_{(1)}^n$ is trivial in P_{n-1} then the extension is the cobordism to the empty set, if it is non-trivial, see Figure 3, then add a representative of $-f \cap \partial e_{(1)}^n$ on the free face

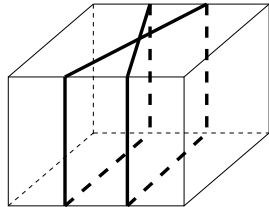

Figure 3: An immersion not extendible over the ball

of $e_{(1)}^n$. Again call f the new extension of ξ , and perform recursively the

same construction. At the end one is left with f defined on $M \setminus \text{int}(e^n)$. \square

LEMMA 6.4. *Let M be an n -manifold, $\xi \in H^{n-2}(M, P_{n-2})$ and f be any extension of ξ to $M \setminus \text{int}(e^n)$. If M is orientable then $f \cap \partial e^n \in P_{n-1}$ depends only on ξ . If M is non-orientable then $f \cap \partial e^n \in P_{n-1}/2P_{n-1}$ depends only on ξ .*

Proof. Given any extension f of ξ to M_{n-1} , the set of extensions modulo cobordism relative to M_{n-2} is acted on by $C_{n-1}(M, P_{n-1})$, by the action $(\alpha * f) \cap e^n = \alpha(e^n) \cup (f \cap e^n)$. This action is transitive. Note that if two extensions f and f' , both extend to $M \setminus \text{int}(e^n)$, then their difference α must be such that for any n -cell $e' \neq e$ it holds $\alpha(\partial e') = 0$.

Assume now that M is orientable. Then at the cochain level $\partial e = \sum_{e' \neq e} \partial e'$, so $\alpha(\partial e) = 0$, and hence $f \cap \partial e = f' \cap \partial e$.

If M is non-orientable the equation $\partial e = \sum_{e' \neq e} \partial e'$ only holds modulo 2, hence one can say that $\alpha(\partial e) \in 2P_{n-1}$.

Assume now that ξ is represented by a different cocycle, hence by a different immersion in M_{n-2} . Since the two cocycles are cohomologous the two immersions are cobordant, hence there exists a cobordism in $M_{n-2} \times I$ between the two representatives. This cobordism can be extended to a cobordism between extensions to M_{n-1} , since any cube $e^{n-1} \times I$ has a free face, say, $e^{n-1} \times \{1\}$, and in an analogous way to a cobordism between two extensions f and f' to $M \setminus \text{int}(e^n)$. This proves that $f \cap \partial e^n$ and $f' \cap \partial e^n$ are cobordant.

That $f \cap \partial e$ does not depend on either e or the process of collapsing is then straightforward, hence the claim. \square

PROPOSITION 6.5. *Let M be an n -manifold and $\xi \in H^{n-2}(M, P_{n-2})$. Then $\xi \in EH^{n-2}(M)$ if and only if, given any extension f of ξ to $M \setminus \text{int}(e^n)$,*

$$f \cap \partial e = 0 \in \begin{cases} P_{n-1}, & \text{if } M \text{ is orientable,} \\ P_{n-1}/2P_{n-1}, & \text{if } M \text{ is non-orientable.} \end{cases}$$

Proof. The case M orientable follows immediately from the preceding lemmas. As for the non-orientable case recall the proof of Proposition 2.5 and Proposition 2.6 and note that if $f \cap \partial e \in 2P_{n-1}$ then its opposite g bounds in $M \setminus \text{int}(e)$ a cobordism not intersecting M_{n-2} . \square

COROLLARY 6.6. *Let n be such that $Q_{n-1} = 0$. Then for any n -manifold*

$$EH^{n-2}(M) = H^{n-2}(M, P_{n-2}).$$

More generally, if n is such that $Q_{n-1} \subseteq 2P_{n-1}$, then the same holds true for non-orientable n -manifolds.

Proof. This immediately follows from Proposition 6.5 and the fact that for any extension f of ξ to $M \setminus \text{int}(e^n)$ the immersion $f \cap \partial e$ belongs to Q_{n-1} . \square

This yields the claimed values for N^{n-2} in all cases but for orientable 4-manifolds. In this case a geometric construction is in order.

PROPOSITION 6.7. *Let M be an orientable 4-manifold and $\xi \in H^2(M, \frac{\mathbf{Z}}{2\mathbf{Z}})$. Then $\xi \in EH^2(M)$ if and only if $\xi \cup \xi = 0$.*

Proof. Assume first that $\xi \cup \xi = 0$, that is, $\xi \in Q^2(M, \mathbf{Z}/2\mathbf{Z})$. Take a smoothly embedded representative F of $PD(\xi)$, and take a generic normal field ν to F in M . The hypothesis on ξ implies that ν has an even number of isolated, simple zeroes z_1, \dots, z_{2s} . Around each zero z_i take a small disk D_i in F such that $\nu|_{\partial D_i}$ has degree 1 or -1. Then cut off all the disks and connect the remaining holes in pairs with tubes which are contained in a tubular neighborhood of F . The resulting surface F' still represents $PD(\xi)$ and admits a nowhere vanishing normal field of directions. Since the group of symmetries of the 8 in \mathbf{R}^2 is equal to the group of symmetries of a line, the existence of the field of directions means that it is possible to decorate F' with 8's. The resulting codimension-one immersion is in F^2 and has second cohomological invariant equal to ξ .

To the contrary, assume it absurd that there exists $\xi \in EH^2(M)$ with $\xi \cup \xi \neq 0$. Consider an embedded surface representing $PD(\xi)$, then choose a normal field to F . Up to changing F in its homology class we can assume as in the previous step that F admits a normal field of directions with a single isolated degenerate point z . Let e^4 be a 4-disk around z in M . One can extend ξ to an immersion defined in $M \setminus \text{int}(e^4)$ by decorating F with 8's following the normal field, call f this immersion. Now $f \cap \partial e^4$ is a non-trivial element of $Q_3 = 2P_3$. If it was trivial, the normal field of directions could be extended to the whole of F , which is not possible. By a local analysis, we can reduce ourselves to the situation of Remark 2.7, hence one obtains that $f \cap \partial e^4$ is in fact the element $4 \in P_3$. But from Proposition 6.5, since M is orientable, $\xi \notin EH^2(M)$. \square

REMARK 6.8. We showed in Proposition 2.5 that $Q_3 = 2P_3$ and in Remark 2.7 that $4P_3$ contains immersions that bound in an orientable manifold. The theory of this section shows that $4P_3$ is the subgroup of immersions bounding in an orientable manifold, that is, immersions with invariants 2 and 6 do *not* bound in any orientable manifold.

This settles the table for $n \leq 4$. One proves now that all obstructions involved in the table are trivial except for \mathcal{O}_2^4 . This fact is due to the

particular properties of P_s and Q_s for $s \leq 6$ and $s \neq 4$. In general, the more the groups P_s are simple the more the extensions \mathcal{O}_k^{s+1} are easy to compute. The easiest case is of course $s = 5$.

PROPOSITION 6.9. *For $k \leq 4$ the extension \mathcal{O}_k^6 is trivial.* \square

The easiest next step is a property of the first obstruction \mathcal{O}_k^{k+2} for some values of k .

PROPOSITION 6.10. *Let k be such that θ_{k+1} is an isomorphism. Then the first obstruction \mathcal{O}_k^{k+2} is trivial.*

Proof. For $\xi \in H^k(M, P_k)$ consider any first extension f to M_{k+1} . Note that $f \cap e^{k+1}$ cannot be considered as an element of P_{k+1} , since $f \cap \partial e^{k+1}$ is not trivial. However the number of $(k+1)$ -tuple points modulo 2 of $f \cap e^{k+1}$ is well defined. Then let $\alpha \in C^{k+1}(M, P_{k+1})$ be the cochain that associates to e^{k+1} this number. Note that the composition with θ_{k+1} induces a natural isomorphism between $C^{k+1}(M, P_{k+1})$ and $C^{k+1}(M, \mathbf{Z}/2\mathbf{Z})$. So we can consider $\alpha * f$, with the action defined in the proof of Lemma 6.3. This immersion extends ξ and is extendible to M_{k+2} , since for any $(k+2)$ -cell e^{k+2}

$$\theta_{k+1}((\alpha * f) \cap \partial e^{k+2}) = \theta_{k+1}(f \cap \partial e^{k+1}) + \sum_{e \in \partial e^{k+1}} \alpha(e) = 0,$$

that is, $(\alpha * f) \cap \partial e^{k+2} = 0 \in P_{k+1}$. \square

The triviality of almost all of the obstructions involved in the table follow then from generalizing the previous results.

The proof of Proposition 6.10 actually extends to the following result, that is in fact the strongest triviality result in this section. Given an immersion however traced on a s -skeleton, if θ_s is an isomorphism then in each s -cube one can force the parity of s -tuple points to be even, and since any $(s+1)$ -cube has an even number of faces, this permits extension to the $(s+1)$ -skeleton.

Theorem 6.11. *Let s be such that θ_s is an isomorphism. Then the obstruction \mathcal{O}_k^{s+1} is trivial, for any $k \leq s-1$.*

Proof. The action defined in the proof of Proposition 6.10 can be defined on the set of extensions from any skeleton to the following one, hence the proof applies. \square

On the other hand, the construction of the unique obstruction for codimension-two cocycles can be performed in a more general context. Specifically, by an easy adaptation of the arguments of Lemmas 6.3 and 6.4 one proves the following proposition:

PROPOSITION 6.12. *Let n be such that $Q_{n-1} = 0$. Then for any n -manifold and any $k \leq n - 2$ the last obstruction \mathcal{O}_k^n is trivial. If n is such that $Q_{n-1} \subseteq 2P_{n-1}$ then the same holds for any non-orientable n -manifold. \square*

We are then left to study N^2 for n -manifolds with $n > 4$, since \mathcal{O}_2^4 is the only nontrivial obstruction involved in the table.

Theorem 6.13. *Let M be a closed orientable n -manifold such that*

$$\text{Ext}(H_3(M, \mathbf{Z}), \mathbf{Z}/8\mathbf{Z}) = 0.$$

Then

$$EH^2(M) \subseteq Q^2(M, \mathbf{Z}/2\mathbf{Z}) \subseteq \ker \mathcal{O}_2^4.$$

Proof. One shows first that $\text{Ext}(H_3(M, \mathbf{Z}), \mathbf{Z}/2\mathbf{Z}) = 0$ implies $EH^2(M) \subseteq Q^2(M, \mathbf{Z}/2\mathbf{Z})$. This condition on Ext is in fact a consequence of $\text{Ext}(H_3(M, \mathbf{Z}), \mathbf{Z}/8\mathbf{Z}) = 0$. Let $\xi \in EH^2(M)$. The hypothesis on M implies by the universal coefficient theorem that $H^4(M, \mathbf{Z}/2\mathbf{Z}) = \text{Hom}(H_4(M, \mathbf{Z}), \mathbf{Z}/2\mathbf{Z})$. We want to prove that $\xi \cup \xi = 0$ by showing that for all $c \in H_4(M, \mathbf{Z})$ one obtains $(\xi \cup \xi)(c) = 0$. Fix a class $c \in H_4(M, \mathbf{Z})$, and represent it by an embedded orientable 4-submanifold F (see [T, Theorem II.27]). One obtains easily $i^*(\xi) \cup i^*(\xi) = 0$, where i is inclusion of F in M . In fact $i^*(\xi)$ is an extendible element of $H^2(F, \mathbf{Z}/2\mathbf{Z})$, and the claim follows from the characterization of Proposition 6.7. Hence $0 = i^*(\xi) \cup i^*(\xi) = i^*(\xi \cup \xi) = PD(\xi \cup \xi)(c)$.

Now we show that $\text{Ext}(H_3(M, \mathbf{Z}), \mathbf{Z}/8\mathbf{Z}) = 0$ implies that $Q^2(M, \mathbf{Z}/2\mathbf{Z}) \subseteq \ker \mathcal{O}_2^4$. Let $\xi \in Q^2(M, \mathbf{Z}/2\mathbf{Z})$, then $\mathcal{O}_2^4(\xi) \in H^4(M, \mathbf{Z}/8\mathbf{Z}) = \text{Hom}(H_4(M, \mathbf{Z}), \mathbf{Z}/8\mathbf{Z})$. For any $c \in H_4(M, \mathbf{Z})$, take as before a representative F orientable and embedded in M . Note that $i^*(\xi) \cup i^*(\xi) = 0$, hence $\mathcal{O}_2^4(i^*(\xi)) = 0 \in H^4(F, \mathbf{Z}/8\mathbf{Z})$. By functorial properties of obstruction cocycles (see [Wh, p. 230]) $\mathcal{O}_2^4(i^*(\xi)) = i^*(\mathcal{O}_2^4(\xi))$, and this last is the set $\mathcal{O}_2^4(\xi) \subset H^4(M, \mathbf{Z}/8\mathbf{Z}) = \text{Hom}(H_4(M, \mathbf{Z}), \mathbf{Z}/8\mathbf{Z})$ evaluated on $c \in H_4(M, \mathbf{Z})$ and composed with Poincaré duality. We proved therefore that this set contains 0 for any $c \in H_4(M, \mathbf{Z})$, hence $\mathcal{O}_2^4(\xi)$ contains the trivial cocycle and so ξ extends over the 4-skeleton. \square

COROLLARY 6.14. *If M is a closed orientable n -manifold, $n \leq 7$, and $\text{Ext}(H_3(M, \mathbf{Z}), \mathbf{Z}/8\mathbf{Z}) = 0$ then*

$$EH^2(M) = Q^2(M, \mathbf{Z}/2\mathbf{Z}).$$

Proof. This is because for $n \leq 7$ the obstruction \mathcal{O}_2^4 is the only one that has not been proven to be trivial yet, hence $EH^2(M) = \ker \mathcal{O}_2^4$. So from Theorem 6.13 we obtain the claim. \square

The results summarized in the table are then proved.

Finally, note that the crucial property of θ_s that makes Proposition 6.10 and Theorem 6.11 work can be abstracted to the following definition:

DEFINITION 6.15. For any $f \in P_{s-1}$ denote by $N(B^s, f)$ the group of immersions g in B^s such that $g \cap \partial B^s$ are cobordant to f . We say s is *simple* if for any $f \in P_{s-1}$ there exists an isomorphism $i_f : N(B^s, f) \rightarrow P_s$ such that

$$\begin{array}{ccc} N(B^s, f) \times N(B^s, -f) & \longrightarrow & N(S^s) \\ i_f \times i_{-f} \downarrow & & \downarrow \sim \\ P_s \times P_s & \longrightarrow & P_s. \end{array}$$

Hence the following theorem holds:

Theorem 6.16. *For simple s the obstruction \mathcal{O}_k^{s+1} is trivial for any $k \leq s - 1$. \square*

6.2 Null-extendible cocycles. We apply obstruction theory to computations concerning $NEH^k(M) \subseteq EH^k(M)$, the subgroup of cocycles that are extendible to null-cobordant immersions. We actually obtain the following satisfactory statement:

Theorem 6.17. *Let M be an n -manifold, with $n \leq 7$. Then, for any $k = 1, \dots, n$,*

$$NEH^k(M) = 0.$$

Proof. We apply Proposition 4.2. We have to prove that, for any $k \leq n \leq 7$, given a cobordism g between k -admissible immersions, one can obtain from g a k -admissible cobordism. By Lemma 4.4 it is enough to show recursively that if g is s -admissible, for $s \leq k - 1$, then one can obtain from it a s -admissible cobordism g' such that for any $(s - 1)$ -cube e^{s-1} of M the intersection $g'(e^{s-1})$ is a trivial element of P_s . Recall that $g'(e^{s-1})$ actually represents an element of P_s since g' is s -admissible. We already know by Proposition 4.3 that any cobordism g between 2-admissible immersions can be considered to be 2-admissible.

Assume then that f and f' are 3-admissible immersions, and let g be a 2-admissible cobordism between them. For any 1-edge e^1 of M the immersion $g(e^1)$ represents a well-defined element of $P_2 = \mathbf{Z}/2\mathbf{Z}$. We define a 2-cocycle in $M \times I$ this way

$$\Lambda(e) = g \cap e.$$

This means that if e is horizontal $\Lambda(e) = 0$ and if e is vertical of the form

$e^1 \times I$ then $\Lambda(e) = g(e^1)$. Note that Λ is closed as a cocycle in $M \times (0, 1)$, since f and f' being 3-admissible implies that $g \cap (M_2 \times \{0, 1\})$ is empty.

We claim that Λ is an extendible cocycle (with compact support) in $M \times (0, 1)$. If it is so, then any associated immersion h in $M \times (0, 1)$ is such that $g' = g \cup h$ is a 2-admissible cobordism such that $g'(e^1) = 0$ for all e^1 , hence can be deformed to a 3-admissible cobordism.

We first build a particular extension of Λ to the vertical 3-skeleton of $M \times I$ this way. Given any vertical 3-cube, note that Λ evaluates non-trivially on an even number of its 4 vertical 2-faces (possibly none). Trace a vertical 8 on any vertical face with non-trivial Λ , and connect the 8's in pairs by means of tubes whose section is a vertical 8. If all of the 4 faces are traced, the pairs must be of adjacent faces. Now note that this first extension is further extendible to the vertical 4-skeleton. Indeed consider any vertical 4-cube. The collection of its 6 vertical 3-faces (that can be visualized as an $S^2 \times (0, 1)$) contains a disjoint union of immersions each representing an element of $2P_3$. But each of these immersions is the trivial element. Indeed by construction the top of the 8 describes a curve which bounds a disk not intersecting the curve of double points, hence having trivial linking number with it, and the double of this linking number is the Arf invariant of the immersion. Hence Λ is extendible to the vertical 4-skeleton. The following obstructions are all trivial by Theorem 6.11, so Λ is extendible to $M \times (0, 1)$, as claimed.

Now given a s -admissible cobordism g between $(s + 1)$ -admissible immersions, $3 < s \leq 7$, define in the same way the s -cochain Λ closed in $M \times (0, 1)$ and by directly applying Theorem 6.11 extend it to an immersion h in $M \times (0, 1)$. Up to adding h an appropriate number of times one obtains a cobordism g' that is still s -admissible but such that $g'(e^{s-1}) = 0$ for all $(s - 1)$ -cube e^{s-1} of M , hence that can be deformed to a $(s + 1)$ -admissible cobordism. \square

7 The Group Structure on Orientable 4-manifolds

The graded group $gr^*(N(M))$ is isomorphic to $N(M)$ as a set, but loses its group structure. We give a result concerning the group structure when M is an orientable 4-manifold.

We first note that for any n -manifold the *total James–Hopf invariant* JH , that is, the product of the James–Hopf invariants composed with Poincaré duality, becomes a homomorphism of groups with $\bigoplus_{j=1}^n H^j(M, P_j)$

endowed with the group structure coming from that of algebra

$$(\alpha * \beta)_j = \alpha_j + \beta_j + \sum_{s+t=j} \alpha_s \beta_t.$$

In dimension 3 the invariant JH completely provides the group structure, up to immersions that are contained in a ball. These last form a subgroup that can be detected by a version of the Arf invariant of P_3 (though Benedetti and Silhol provided a deeper invariant). Up to immersions in a ball, any class can be realized as the decoration of an embedded representative and any immersion can be split in a unique way as the sum of immersions obtained by decorating a submanifold, that is, JH is surjective and injective. Neither of those properties holds for orientable 4-manifolds. Indeed from the main theorem self-intersection of 2-classes is the (only) obstruction for decorating an embedded representative. Moreover decorating a simple curve with an element of $2P_3$ provides an immersion in F^3 with trivial JH but non-trivial χ^3 .

We define the map k from $H_1(M, \mathbf{Z}/4\mathbf{Z}) = H_1(M, \mathbf{Z}) \otimes \mathbf{Z}/4\mathbf{Z}$ in $N(M)$ that associates to $\gamma \otimes m$ an embedded curve representing γ decorated by the canonical immersion with invariant $2m$. This map results in being well defined, that is, $\gamma \times 2m$ does not depend on either the representative of γ or on the trivialization of the normal bundle. Moreover the image of JH is the subgroup of $\bigoplus_{j=1}^4 H^j(M, P_j)$ whose support is $H^1(M, \mathbf{Z}/2\mathbf{Z}) \oplus Q^2(M, \mathbf{Z}/2\mathbf{Z}) \oplus H^3(M, \mathbf{Z}/2\mathbf{Z}) \oplus H^4(M, \mathbf{Z}/2\mathbf{Z})$ (see [G1] for more details). The following holds.

PROPOSITION 7.1. *There is a short exact sequence of groups*

$$0 \rightarrow H_1(M, \mathbf{Z}/4\mathbf{Z}) \xrightarrow{k} N(M) \xrightarrow{JH} H^1(M, \mathbf{Z}/2\mathbf{Z}) * Q^2(M, \mathbf{Z}/2\mathbf{Z}) * H^3(M, \mathbf{Z}/2\mathbf{Z}) * H^4(M, \mathbf{Z}/2\mathbf{Z}) \rightarrow 0.$$

Proof. That k is injective follows from the fact that images of different cycles have different χ^3 and this last is injective. We show exactness in the middle term. That $JH(k(\alpha \otimes m))$ is trivial for any $\alpha \otimes m \in H_1(M, \mathbf{Z}) \otimes \mathbf{Z}/4\mathbf{Z}$ follows since any representative f of $k(\alpha \otimes m)$ has no triple points nor quadruple points, and the locus of its double points is a surface representing the trivial element of $H_2(M, \mathbf{Z}/2\mathbf{Z})$. The whole of f retracts on the decorated curve in fact, hence also $JH_3(f)$ is trivial. Now suppose that $JH(f) = (0, 0, 0, 0)$. We must prove that f is in the image of the map k . Since $\chi^1(f) = JH_3(f) = 0$, from Lemma 4.9 f belongs to F_2 . Assume then that f is 2-admissible. Now f has trivial second cohomological invariant, since $\chi^2(f) = PD(JH_2(f))$, hence in particular f belongs

to F^3 , see Proposition 4.9. Assume that f is 3-admissible and consider $\chi^3(f) \in H^3(M, P_3)$. This class has trivial reduction modulo 2, since

$$\chi^3(f)(\text{mod } 2) = PD(JH_1(f)) = 0,$$

so there is an element $\kappa_f \in H_1(M, \mathbf{Z}/4\mathbf{Z})$ such that $\chi^3(f) = 2PD(\kappa_f)$. It is easy to see that $f = k(\kappa_f)$. \square

EXAMPLE 7.2. The group of the complex projective plane is $N(\mathbf{CP}^2) = \mathbf{Z}/2\mathbf{Z}$ generated by a non-trivial immersion in a small ball.

REMARK 7.3. The cobordism group of a 4-manifold is generated by embedded decorated submanifolds. It is proven in [BS] that the cobordism class of a codimension-one embedding only depends on homology modulo 2, and in [G1] that the cobordism class of a decorated curve only depends on the (oriented) homology of the curve and the cobordism class of the decorating immersion. So if M is an oriented 4-manifold such that $Q^2(M, \mathbf{Z}/2\mathbf{Z}) = 0$ one can choose a the set of generators of $N(M)$ by choosing a set $\{C_j\}$ of oriented curves generating $H_1(M, \mathbf{Z})$ and a set $\{S_k\}$ of codimension-one embeddings generating $H^1(M, \mathbf{Z}/2\mathbf{Z})$ and considering the set $\{\cdot \times P, C_j \times B, S_k \times \cdot\}$, B denoting the left Boy immersion and P denoting a generator of P_4 .

REMARK 7.4. The image of $PD(JH_2)$ being $Q^2(M, \mathbf{Z}/2\mathbf{Z})$ implies in particular that for any pair of 1-cocycles modulo 2, α and β , the relation $\alpha^2\beta^2 = 0$ holds. This fact has an elementary geometric proof. Represent the dual of α and β by means of embedded hypersurfaces A and B . Note that if A is orientable then α^2 is 0, and if A is non-orientable its self-intersection is the orientation cycle of A , hence can be represented by an orientable surface F in A . Call C the curve intersection between F and B . Then a representative of the dual of $\alpha^2\beta^2$ is the intersection between C and B . But the normal bundle to B restricted to C is orientable since it is the normal bundle to C in F , that is trivial since F is orientable, and hence $C \cdot B = 0$.

References

- [BS] R. BENEDETTI, R. SILHOL, *Spin* and *Pin*⁻ structures, immersed and embedded surfaces and a result of Segre on real cubic surfaces, *Topology* 34 (1995), 651–678.
- [C] J.S. CARTER, On generalizing Boy's surface: constructing a generator of the third stable stem, *Trans. A.M.S.* 298 (1986), 103–122.

- [F] L. FUNAR, Cubulations, immersions, mappability and a problem of Habegger, *Ann. Sci. École Norm. Sup.* 32 (1999), 681–700.
- [G1] R. GINI, Cobordism of codimension-one immersions, PhD. Thesis, Università di Pisa, Dipartimento di Matematica, 2001.
- [G2] R. GINI, Cobordism of immersions of surfaces in non-orientable 3-manifolds, *Manuscripta Math.* 104 (2001), 49–69.
- [HH] J. HASS, J. HUGHES, Immersions of surfaces in 3-manifolds, *Topology* 24 (1985), 97–112.
- [Hi] P. HILTON, *General Cohomology Theory and K-Theory*, v.1, Lecture Note Series, Cambridge University Press, 1971.
- [J] I.M. JAMES, On the suspension triad, *Ann. of Math.* 63 (1956), 191–247.
- [K] R. KIRBY, Problems in low-dimensional topology, "Geometric Topology", Georgia International Topology Conference vol. 2, (W.H. Kazez, ed.), *Studies in Advanced Math*, AMS-IP (1995), 35–472.
- [KoS] U. KOSCHORKE, B. SANDERSON, Self-intersections and higher Hopf invariants, *Topology* 17 (1978), 283–290.
- [L] A. LIULEVICIUS, A theorem in homological algebra and stable homotopy of projective spaces, *Trans. A.M.S.* 109 (1963), 540–552.
- [M] W.S. MASSEY, *Singular Homology Theory*, Graduate Texts in Math., Springer, 1980.
- [N] T. NOWIK, Quadruple points of regular homotopies of surfaces in 3-manifolds, *Topology* 39 (2000), 1069–1088.
- [P] R.A. PICCININI, *Lectures on Homotopy Theory*, North-Holland, 1992.
- [Pi] U. PINKALL, Regular homotopy classes of immersed surface, *Topology* 24 (1985), 421–434.
- [T] R. THOM, Quelques propriétés globales des variétés différentiables, *Comment. Math. Helvetici* 28 (1954), 17–86.
- [V] P. VOGEL, Cobordisme d'immersions, *Ann. Sci. École Norm. Sup.* 7 (1974), 317–358.
- [W] R. WELLS, Cobordism groups of immersions, *Topology* 5 (1966), 281–294.
- [Wh] G.W. WHITEHEAD, *Elements of Homotopy Theory*, Graduate Texts in Math., Springer, 1978.

LOUIS FUNAR, Institut Fourier BP 74, UMR 5582 CNRS, University of Grenoble I, 38402 Saint-Martin-d'Hères cedex, France funar@fourier.ujf-grenoble.fr

ROSA GINI, Department of Mathematics, University of Pisa, via Buonarroti 2, 56127 Pisa, Italy gini@dm.unipi.it

Submitted: August 2001
Revision: September 2002