

Stable twisted curves and their r -spin structures

Alessandro Chiodo*

January 22, 2007

Abstract

The object of this paper are r -spin structures: line bundles whose r th power is isomorphic to the canonical bundle ($L^{\otimes r} \cong \omega$). Over the moduli M_g of smooth genus- g curves, r -spin structures are parametrized by a finite torsor $M_g^{\omega,r}$ under the finite group stack $M_g^{\otimes,r}$ of r -torsion line bundles ($L^{\otimes r} \cong \mathcal{O}$). The problem is compactifying $M_g^{\omega,r}$ by means of some kind of stable curves and preserving the torsor structure. Over the moduli \overline{M}_g of stable curves, both r -spin structures and r -torsion line bundles are parametrized by étale stacks, but the finiteness and the torsor structure are lost.

In the present work, we show how this bad picture can be definitely improved simply by placing the problem in the category of twisted curves (a kind of stack-theoretic curves introduced by Abramovich and Vistoli), and describing the notion of stability there. For a given multiindex $\vec{l} = (l_0, l_1, \dots, l_{\lfloor g/2 \rfloor})$ of positive integers, we say that a twisted curve is \vec{l} -stable if its stabilizers have order l_i on nodes of type i . These multiindexes classify all the compactifications $M_g(\vec{l})$ of M_g which are smooth Deligne–Mumford stacks within Olsson’s nonseparated stack of twisted curves. Over $M_g(\vec{l})$, as soon as r divides l_0 , the group stack $M_g^{\otimes,r}(\vec{l})$ of r -torsion line bundles on \vec{l} -stable curves is finite; furthermore, as soon as r divides $l_i(2i - 1)$ for each i , the r -spin structures on \vec{l} -stable curves form a finite torsor $M_g^{\omega,r}(\vec{l})$ under $M_g^{\otimes,r}(\vec{l})$. This yields natural compactifications of $M_g^{\omega,r}$, which can be efficiently employed in enumerative geometry. We illustrate the relation with previous constructions due to Abramovich and Jarvis.

1 Introduction

Higher spin structures are natural generalizations of theta characteristics: on a space, they are given by a line bundle L and an isomorphism $f: L^{\otimes r} \xrightarrow{\sim} \omega$ for an integer r greater than 2. The object of this paper are their moduli stacks. We fix $r \geq 2$ and work over an algebraically closed field k , whose characteristic is prime to r .

*Financially supported by the Marie Curie Intra-European Fellowship within the 6th European Community Framework Programme, MEIF-CT-2003-501940.

1.1 Smooth curves: the r th roots form a torsor

For $g \geq 2$ and $2g - 2 \in r\mathbb{Z}$, the category of r -spin structures on smooth genus- g curves forms a Deligne–Mumford stack $\mathbb{M}_g^{\omega,r}$, finite and étale on \mathbb{M}_g , which we write as

$$\mathbb{M}_g^{\omega,r} = \{(C, L, f) \mid f: L^{\otimes r} \xrightarrow{\sim} \omega_C\}_{/\cong} \longrightarrow \mathbb{M}_g.$$

In fact $\mathbb{M}_g^{\omega,r}$ is a finite torsor under the finite group stack of r -torsion line bundles on smooth genus- g curves:

$$\mathbb{M}_g^{\mathcal{O},r} = \{(C, L, f) \mid f: L^{\otimes r} \xrightarrow{\sim} \mathcal{O}_C\}_{/\cong} \longrightarrow \mathbb{M}_g.$$

1.2 Stable curves: the torsor is lost

When we extend the study of r -spin structures to the category of stable curves $\overline{\mathbb{M}}_g$, the properness and the torsor structure are lost.

First, consider the category $\overline{\mathbb{M}}_g^{\mathcal{O},r}$ of r -torsion line bundles on stable curves. As above, it forms an étale stack on $\overline{\mathbb{M}}_g$ which is equipped with a group structure. However, $\overline{\mathbb{M}}_g^{\mathcal{O},r} \rightarrow \overline{\mathbb{M}}_g$ is not proper. Indeed, since $\overline{\mathbb{M}}_g^{\mathcal{O},r}$ is étale and the generic fibre contains r^{2g} points, one can check that the valuative criterion fails by exhibiting an example of a geometric fibre with less than r^{2g} points.

1.2.1 Example. Consider an irreducible curve of genus g with only one node. Note that the set of roots of \mathcal{O} consists of r^{2g-1} elements. Indeed, and more generally, for any stable curve C the group of r -torsion line bundles $\text{Pic}(C)_r$ fits in the exact sequence

$$1 \rightarrow \mu_r \rightarrow (\mu_r)^{\#V} \rightarrow (\mu_r)^{\#E} \rightarrow (\text{Pic } C)_r \rightarrow (\text{Pic } C^\nu)_r \rightarrow 1 \quad (1.2.2)$$

where V and E are the sets of irreducible components and of singularities of the curve C , whereas C^ν is the normalization of C . So, we get

$$\#((\text{Pic } C)_r) = r^{2g-1+\#(V)-\#(E)}. \quad (1.2.3)$$

Second, write $\overline{\mathbb{M}}_g^{\omega,r}$ for the category of r -spin structures on stable curves. In fact, the morphism to $\overline{\mathbb{M}}_g$ is étale; however, it is not proper and it is not a torsor on $\overline{\mathbb{M}}_g$. Indeed, the following example shows that the morphism to $\overline{\mathbb{M}}_g$ is not surjective.

1.2.4 Example. Let C be a curve with only one node and two irreducible components of genus $g - 1$ and 1 , respectively. Then there are no r th roots of ω on C . This happens because the degree of ω is 1 on the genus- 1 component of C . Indeed, recall that the degree of the dualizing sheaf ω on an irreducible component C' of genus i is $2i - 2 - \#(N)$ where N is the set of points where C' meets the rest of the curve (by “genus” we always mean the *arithmetic* genus as in §2.3).

In the recent years, the interest in moduli of r -spin structures has been revived by Witten’s conjecture [Wi93], which relates certain enumerative properties of r -spin structures to the Gelfand–Dikiĭ hierarchy. The conjecture is a generalization of the Kontsevich–Witten Theorem [Wi91] [Ko92] and has been lately proven in [FSZ]. This result opens the way to further investigations of Gromov–Witten r -spin theory.

The original formulation of the relevant enumerative properties was only sketched by Witten in [Wi93]. A rigorous definition requires—first of all—a compactification of $M_g^{\omega,r}$ (once a suitable compactification is given, the numerical invariants can be defined using [PV01] or [Ch1], see Proposition 4.3.7).

In the existing literature, there are several solutions to the problem of compactifying $M_g^{\omega,r}$: they consist in enlarging the category $M_g^{\omega,r}$ of smooth r -spin curves (C, L, f) to a new category fibred over \overline{M}_g . In [Ja98] and [Ja00], Jarvis allows noninvertible sheaves. In [Co87] for $r = 2$ and [CCC] in general, Cornalba, Caporaso, and Casagrande take as new objects line bundles on semistable curves. In [AJ03] Abramovich and Jarvis realize the same category as in [Ja00] in terms of stack-theoretic curves [AJ03]. In all these compactifications the torsor structure is lost over \overline{M}_g , because ramification occurs at the new points [Ja00, Thm. 2.4.2] and [CCC, §3, §4.1].

1.3 Placing the problem in the context of twisted curves: \vec{l} -stability

We consider the category \widetilde{M}_g of twisted curves, which are, over an algebraically closed field, stack-theoretic curves whose smooth geometric locus is represented by a scheme and whose stabilizers at the nodes have finite order (see Abramovich and Vistoli [AV02] or Section (2.4) for the definition over a base scheme X).

By Olsson’s Theorem [Ol], \widetilde{M}_g forms an algebraic stack. However, the stack \widetilde{M}_g is nonseparated. Indeed, a twisted curve C over a discrete valuation ring R with smooth generic fibre C_K is isomorphic to its coarse space over the field of fractions K and may differ from it on the special fibre; in this case the coarse space $|C|$ and the twisted curve C are two nonisomorphic twisted curves extending C_K over R . Therefore, the valuative criterion of separateness fails.

We describe the condition of stability in the category of twisted curves \widetilde{M}_g . For any multiindex $\vec{l} = (l_0, l_1, \dots, l_{\lfloor g/2 \rfloor})$ of integers prime to $\text{char}(k)$, we say that a twisted curve is \vec{l} -stable if its stabilizers have order l_i on nodes of type i (the notion of type of a node can be found in [DM69] and is recalled in (4.1.2)). In this way, for each multiindex \vec{l} , we have a notion of stability, which corresponds to a new compactification of M_g (the classical Deligne–Mumford–Knudsen compactification \overline{M}_g corresponds to $\vec{l} = (1, \dots, 1)$). In the following theorem, we show that the compactifications obtained in this way are all the compactifications of M_g inside \widetilde{M}_g .

4.1.4 Theorem. *Let us denote by $M_g(\vec{l})$ the category of \vec{l} -stable curves. It is contained in \widetilde{M}_g and it contains M_g :*

$$M_g \hookrightarrow M_g(\vec{l}) \hookrightarrow \widetilde{M}_g.$$

- I. *The stack $M_g(\vec{l})$ is tame, proper (separated), smooth, irreducible and of Deligne–Mumford type. The morphism $M_g(\vec{l}) \rightarrow \overline{M}_g$ is finite, flat, and is an isomorphism on the open dense substack M_g .*
- II. *Any proper substack X of \widetilde{M}_g fitting in $M_g \hookrightarrow X \hookrightarrow \widetilde{M}_g$ is isomorphic to $M_g(\vec{l})$ for a suitable multiindex \vec{l} .*

1.4 The torsor of r th roots of a bundle and the torsor of r -spin \vec{l} -stable curves

For any line bundle F on the smooth universal curve on M_g whose relative degree is a multiple of r the category $M_g^{F,r}$ of r th roots of F on curves $C \rightarrow X$ forms a stack, étale and finite on M_g ,

and equipped with a torsor structure under the group stack $M_g^{\mathcal{O},r}$.

It is well known that F can be written as a power $\omega^{\otimes k}$ of the relative dualizing sheaf on the universal curve modulo pullbacks from M_g (Enriques and Franchetta's conjecture [Ha83] [Me87] [AC87]). Therefore, in view of an extension of $M_g^{F,r}$ over \tilde{M}_g , we focus on the case $F = \omega^{\otimes k}$ and we assume $(2g - 2)k \in r\mathbb{Z}$. We compactify $M_g^{F,r}$ in two steps:

- (1) over \tilde{M}_g , we construct the stack parametrizing r th roots of $F = \omega^{\otimes k}$;
- (2) we restrict such stack to the compactifications $M_g(\vec{l}) \subset \tilde{M}_g$ for suitable indexes \vec{l} .

For (1), we define the stack $\tilde{M}_g^{F,r}$ of r th roots of $F = \omega^{\otimes k}$ on twisted curves

$$\tilde{M}_g^{F,r} = \{(C, L, f) \mid f: L^{\otimes r} \xrightarrow{\sim} F_C\} /_{\cong} \longrightarrow \tilde{M}_g.$$

Note that $\tilde{M}_g^{F,r}$ can be regarded as the fibred product $(\widetilde{LB}_g)_{k_r \times_F} \tilde{M}_g$, where \widetilde{LB}_g is the stack of line bundles on twisted curves, k_r is induced by the r th power in $B\mathbb{G}_m \rightarrow B\mathbb{G}_m$, and F is regarded as a section $\tilde{M}_g \rightarrow \widetilde{LB}_g$. We show that $\tilde{M}_g^{F,r}$ is a Deligne–Mumford stack, étale on \tilde{M}_g .

For (2), we choose a multiindex $\vec{l} = (l_0, l_1, \dots, l_{\lfloor g/2 \rfloor})$ and we consider the restriction $M_g^{F,r}(\vec{l}) \rightarrow M_g(l)$ of $\tilde{M}_g^{F,r} \rightarrow \tilde{M}_g$. In this way, for each \vec{l} , we obtain a stack $M_g^{F,r}(\vec{l})$ of r th roots of F on \vec{l} -stable curves fibred over $M_g(\vec{l})$. The properness and the torsor structure are lost for general choices of \vec{l} as we already pointed out in the case $\vec{l} = (1, \dots, 1)$, which corresponds to stable curves. The following theorem determines the suitable choices of \vec{l} .

4.2.3 Theorem. *For any $F = \omega^{\otimes k}$, the category $M_g^{F,r}(\vec{l})$ is a smooth Deligne–Mumford algebraic stack, étale on $M_g(\vec{l})$.*

- I. *For $F = \mathcal{O}$, the stack $M_g^{\mathcal{O},r}(\vec{l})$ is a finite group stack if and only if we have*

$$l_0 \in r\mathbb{Z}.$$

- II. *For $F = \omega$ and $2g - 2 \in r\mathbb{Z}$, the stack $M_g^{\mathcal{O},r}(\vec{l})$ is a finite group stack and $M_g^{\omega,r}(\vec{l})$ is a finite torsor under $M_g^{\mathcal{O},r}(\vec{l})$ if and only if we have*

$$(2i - 1)l_i \in r\mathbb{Z} \text{ for all } i.$$

In this way, we obtain several compactifications of the stack $M_g^{\omega,r}$ of smooth r -spin curves: for each \vec{l} satisfying $l_i(2i - 1) \in r\mathbb{Z}$,

$$M_g^{\omega,r}(\vec{l}) \rightarrow M_g(\vec{l})$$

is the finite torsor of r -spin \vec{l} -stable curves.

- III. *More generally, for $F = \omega^{\otimes k}$ and $(2g - 2)k \in r\mathbb{Z}$, the stack $M_g^{\mathcal{O},r}(\vec{l})$ is a finite group stack and $M_g^{F,r}(\vec{l})$ is a finite torsor under $M_g^{\mathcal{O},r}(\vec{l})$ if and only if we have*

$$l_0 \in r\mathbb{Z} \quad \text{and} \quad (2i - 1)kl_i \in r\mathbb{Z}, \text{ for } i > 0.$$

The fact that these compactifications allow a natural extension the torsor structure of r th roots defined on the initial uncompactified moduli stack is an improvement in its own right. We also mention some concrete situations in enumerative geometry where this construction is useful:

Gromov–Witten potential of $[\mathbb{C}^2/\mathbb{Z}_r]$. In actual calculations of enumerative geometry of curves, one of the advantages of describing r th roots via a new notion of stability is that we can generalize to r th roots the usual technology employed for stable curves. In [Ch3], we generalize Mumford’s GRR formula for the Chern character of the Hodge bundle to the direct image in K -theory of the universal r th root of F . This formula allows direct evaluations [Ch3, §4] of Gromov–Witten invariants of the stack $[\mathbb{C}^2/\mathbb{Z}_r]$, which are the subject of the crepant resolution conjecture [BG] (the algorithm computing the invariants involves the values $l_0, l_1, \dots, l_{\lfloor g/2 \rfloor}$ appearing in the above theorem, see [Ch3, Cor. 3.1.35]).

Tensor products of r th roots. In [JKV00, Rem. 4.11] the authors point out that the natural isomorphism $M_g^{F, r_1 r_2} \cong M_g^{F, r_1} \times_{M_g} M_g^{F, r_2}$, for relatively prime indexes r_1 and r_2 , does not extend to the boundary. We point out in Proposition 4.2.10 that the new compactification allows us to extend the equivalence $L \mapsto (L^{\otimes r_2}, L^{\otimes r_1})$ to the boundary over the category of twisted curves with stabilizers of order $r_1 r_2$ on all nodes ($r_1 r_2$ -stable curves).

In fact, in this way, we get smooth compactifications of the moduli functor of m -tuples of spin structures of orders r_1, \dots, r_m used in [JKV00, Thm. 6.2] to describe tensor products of Frobenius manifolds (note that, because of ramifications, taking the fibred product as in [JKV00, §4.2] using Jarvis’s compactifications does not yield a smooth compactification).

Counting boundary points. The description of the geometric points of the boundary locus becomes straightforward: for the indexes \vec{l} defined in the previous theorem, the boundary points are simply represented by \vec{l} -stable curves with their r^{2g} distinct r th roots. We illustrate in Example 4.2.11 that this improves our understanding of the enumerative geometry of r th roots: we show how to count the number of r -spin structures on a twisted curve C up to automorphism of C . This leads to a counterexample of Conjecture 4.2.1 of [Ja01], which states that the Picard group of the moduli stack of smooth genus-1 r -spin structures is finite, see Example 4.2.14.

Finally, we point out that the results obtained with previous compactifications extend easily to the above stacks $M_g^{F, r}(\vec{l})$. In fact, for several issues in the theory of r -spin curves, the reformulation in terms of the étale compactifications constructed here eliminates multiplicity factors due to ramifications: the main example is the construction of cohomological field theories in [JKV01, §4.1], see Remark 4.2.1 therein on ramifications. In Proposition 4.3.3, we show that there is a surjective morphism from our compactification to the preexisting compactification due to Abramovich and Jarvis and illustrate where this morphism is not invertible. In Proposition 4.3.7, we prove that the functor of [PV01] and [Ch1] defining the Witten top Chern class yields a class in the rational cohomology of the new compactification and we show that such a class is compatible with previous constructions.

1.5 Structure of the paper

In Section 2, we fix our terminology and prove some preliminary results.

In Section 3 we prove the main technical results. §3.1 is a brief subsection where we prove

that the functor of r th roots of a line bundle on a twisted curve on a base scheme X is a Deligne–Mumford stack étale on X . §3.2 focuses on the problem of describing the fibres of this functor on closed points of X : we work out the Kummer theory of a twisted curve and compare the long exact Kummer sequence of a twisted curve to that of its coarse space, Theorem 3.2.3. In particular, we state a criterion for a line bundle F to have r^{2g} r th roots on a twisted curve, see Theorem 3.2.2 and see Figure 2 at 3.2.22.

By applying these results, in Section 4, we prove Theorem 4.1.4 and Theorem 4.2.3 stated above. We illustrate these theorems in Example 4.2.11. We describe the relation with the previous compactification of Abramovich and Jarvis, Proposition 4.3.3.

In the Appendix we show that line bundles over twisted curves form a stack. A more general treatment which extends to coherent sheaves and proves that such a stack is algebraic can be found in [Li06].

1.6 Acknowledgements

I would like to thank Arnaud Beauville, Alessio Corti, Carlos Simpson, Angelo Vistoli, and Charles Walter for comments and help, and especially André Hirschowitz for numerous stimulating discussions and for careful reading of preliminary versions of this paper.

2 Terminology and preliminaries

2.1 Schemes

We work with schemes locally of finite type over an algebraically closed field k , their localizations, and their completions. We fix a positive integer r and assume that it is invertible in k .

2.2 Stacks

Terminology and generalities. Our general reference for stacks is [LM00]. An *algebraic stack* is a stack satisfying Artin’s definition [Ar74]. Stacks in the sense of Deligne and Mumford [DM69] will be called *Deligne–Mumford stacks*. We always work with algebraic stacks locally of finite type over a locally noetherian scheme. When working with algebraic stacks with finite diagonal, we use Keel and Mori’s Theorem [KM97]: there exists an algebraic space $|X|$ associated to the stack X and a morphism $\pi_X: X \rightarrow |X|$ (or simply π) which is universal with respect to morphisms from X to algebraic spaces. We refer to $|X|$ as the *coarse space*. In this way we have a functor (and in fact a 2-functor) associating to any morphism between this type of stacks $f: X \rightarrow Y$ the unique morphism between the corresponding coarse algebraic spaces $|f|: |X| \rightarrow |Y|$ satisfying $f \circ \pi_Y = \pi_X \circ |f|$.

We refer to [Br90] for the notion of *group stack* $G \rightarrow X$. We say that there is an action of the group stack $G \rightarrow X$ with product m_G and unit object e on $T \rightarrow X$ if there is a morphism of stacks $m: G \times_X T \rightarrow T$ and homotopies $m \circ (m_G \times \text{id}_T) \Rightarrow m(\text{id}_G \times m)$ and $m \circ (e \times \text{id}_T) \Rightarrow \text{id}_T$ satisfying the associativity constraint [Br90, 6.1.3] and the compatibility constraint [Br90, 6.1.4]. The morphism $T \rightarrow X$ is a *torsor* if the morphism

$$m \times \text{pr}_2: G \times_X T \rightarrow T \times_X T$$

is an isomorphism of stacks and the geometric fibres of $T \rightarrow X$ are nonempty.

Morphisms of stacks. We often need to consider 2-categories in which the objects are algebraic stacks, the functors between two stacks are regarded as 1-morphisms, and the natural transformations are regarded as 2-morphisms. The situation is often simplified by the following criterion showing that certain morphisms between stacks have only trivial 2-automorphisms. In particular this criterion applies to morphisms between twisted curves.

2.2.1 Lemma (Abramovich and Vistoli, [AV02, Lem. 4.2.3]). *Let $f: X \rightarrow Y$ be a representable morphism of Deligne–Mumford stacks over a scheme S . Assume that there exists a dense open representable substack (i.e. an algebraic space) $U \subset X$ and an open representable substack $V \subset Y$ such that f maps U into V . Further assume that the diagonal $Y \rightarrow Y \times_S Y$ is separated. Then any automorphism of f is trivial. \square*

Stabilizer of a geometric point of a stack. Let X be an algebraic stack. A geometric point $p \in X$ is an object $\text{Spec } k \rightarrow X$. We denote by $\text{Aut}(p)$ the automorphism group of p as an object of the fibred category X_p . We refer to $\text{Aut}(p)$ as the *stabilizer* of p .

Local pictures. We often need to describe stacks and morphisms between stacks locally in terms of explicit equations. We adopt the following standard convention, which avoids repeated mention of strict henselization [ACV03, §1.5].

Let X and U be algebraic stacks and let $x \in X$ and $u \in U$ be geometric points. We say “the local picture of X at x is given by U (at u)” if there is an isomorphism between the strict henselization X^{sh} of X at x and the strict henselization U^{sh} of U at u .

If $f: X \rightarrow Y$ and $g: U \rightarrow V$ are morphisms of stacks and x and u are geometric points in X and U , we say “the local picture of $X \rightarrow Y$ at x is given by $U \rightarrow V$ (at u)” if there is an isomorphism between the strict henselization $f^{\text{sh}}: X^{\text{sh}} \rightarrow Y^{\text{sh}}$ of f at x and the strict henselization $g^{\text{sh}}: U^{\text{sh}} \rightarrow V^{\text{sh}}$ of g at u . This convention allows local descriptions of diagrams of morphisms between stacks; in particular it allows local description of group actions $G \times X \rightarrow X$ and of G -equivariant morphisms.

The construction of Cadman, Matsuki, Olsson, and Vistoli. For any smooth scheme X and smooth effective divisor D in X we present a stack-theoretic modification of X , which contains $X \setminus D$ as a dense open representable substack and has coarse space X .

In [Cad], Cadman provides the following construction.

2.2.2 Definition. Let X be a smooth scheme X , let D be a smooth effective Cartier divisor in X , and let l be a positive integer invertible on X . The category $X[D/l]$ is formed by objects (S, M, j, s) , where

1. S is an X -scheme $S \rightarrow X$;
2. M is a line bundle on S ;
3. j is an isomorphism between $M^{\otimes l}$ and the pullback of $\mathcal{O}(D)$ on S ;
4. s is a section $s \in \Gamma(S, M)$ such that $j(s^{\otimes l})$ equals the tautological section of $\mathcal{O}(D)$ vanishing along D .

The morphisms are defined in the obvious way.

This definition yields a Deligne–Mumford stack $X[D/l]$, with coarse space X . The morphism $\pi: X[D/l] \rightarrow X$ is an isomorphism over $X \setminus D$: we have

$$X \setminus D \hookrightarrow X[D/l] \xrightarrow{\pi} X,$$

where $X \setminus D$ is dense in $X[D/l]$ and π is finite and flat. Note that $X[D/l]$ is equipped with a tautological line bundle M and an isomorphism

$$M^{\otimes l} \xrightarrow{\sim} \pi^* \mathcal{O}_X(D). \quad (2.2.3)$$

A special case of this construction was first introduced by Abramovich, Graber, and Vistoli [AGV01, 3.5.3] (the idea is attributed to Vistoli, see [Ab, 3.5]). In the existing literature, two different and compatible definitions can be found: see Matsuki and Olsson [MO05] and Cadman [Cad] for the above definition (see [Cad, 2.4.5] for the compatibility between the two constructions).

It is natural to try and generalize this construction. If D_1, \dots, D_n are distinct smooth effective divisors with normal crossings, for any positive integers l_1, \dots, l_n invertible on X , we write

$$X[D_1/l_1 + \dots + D_n/l_n] := X[D_1/l_1] \times_X \dots \times_X X[D_n/l_n]. \quad (2.2.4)$$

In this way, $X[D_1/l_1 + \dots + D_n/l_n]$ is a smooth Deligne–Mumford stack.

2.2.5 Generalization. The definition provided in [MO05] by Matsuki and Olsson generalizes the above definition of $X[D_1/l_1 + \dots + D_n/l_n]$ to the case where singular divisors D_i occur, and the local picture of D_i at each point is the union of smooth divisors with normal crossings (a normal crossings divisor). This extension involves the notion of logarithmic structures in the sense of Fontaine and Illusie or the use of étale descent. The output is again a smooth stack, see [MO05, Thm. 4.1].

2.2.6 Example. Consider the affine space $X = \text{Spec } R$ and the divisor $D = \{t = 0\}$ for $t \in R$. Assume that l is invertible in R . The stack $X[D/l]$ is the quotient stack $[\text{Spec } \tilde{R}/\mu_l]$, where $\tilde{R} = \text{Spec } R[\tilde{t}]/(\tilde{t}^l - t)$ and μ_l acts on \tilde{R} as $g \cdot \tilde{t} = g^{-1}\tilde{t}$ and fixes R .

2.2.7 Example. Let X be a Deligne–Mumford stack, whose coarse space is a proper, regular, and reduced curve $|X|$ and whose geometric points have trivial stabilizers except for a finite number of distinct points $\mathfrak{p}_1, \dots, \mathfrak{p}_n$ with stabilizers of order l_1, \dots, l_n (which we assume invertible in k). In that case, we have (see [Cad, Exa. 3.7])

$$X \cong |X|[p_1/l_1 + \dots + p_n/l_n]$$

where $p_i = |\mathfrak{p}_i| \in |X|$ is the point corresponding to $\mathfrak{p}_i \in X$. The local picture at \mathfrak{p}_i is given by $S[0/l_i]$, where $S = \text{Spec } k[z]$ and 0 denotes $\{z = 0\}$. In this way there is an isomorphism between $\text{Aut}(\mathfrak{p}_i)$ and cyclic group of l_i th roots of unity of \mathbb{G}_m .

2.2.8 Remark. At each point \mathfrak{p}_i of $X = |X|[p_1/l_1 + \dots + p_n/l_n]$ the projection

$$j_i: \mathbf{B}(\text{Aut}(\mathfrak{p}_i)) = \text{Spec } k_{|\mathfrak{p}_i|} \times_{\pi} X \xrightarrow{\text{pr}_2} X$$

is a canonical embedding. The group $\text{Pic}(\mathbf{B}(\text{Aut } \mathfrak{p}_i))$ is a cyclic group of order l_i . The tangent

space \mathbb{T}_i at \mathfrak{p}_i is a representation of $\text{Aut}(\mathfrak{p}_i)$ and is a canonical generator of $\text{Pic}(\text{Aut } \mathfrak{p}_i)$. In this way $\text{Pic}(\text{Aut } \mathfrak{p}_i)$ is canonically isomorphic to $\mathbb{Z}/l_i\mathbb{Z}$.

2.2.9 Remark. On a Deligne–Mumford stack of dimension 1, the degree of a line bundle F is the degree of the first Chern class $c_1(F)$ in the rational Chow ring $A^1(X)_{\mathbb{Q}}$. Therefore $\deg(F)$ is a rational number, see [Kr99, 3.3] and references therein. In the case of $C[p/d]$, we have the following proposition.

2.2.10 Proposition. *Let C be a proper, regular, and reduced curve. For a closed point $p \in C$ and l a positive integer, consider $\pi: C[p/l] \rightarrow C$. We write Γ for the stabilizer of the point of $C[p/l]$ over p and write $j: \text{B}\Gamma \rightarrow C[p/d]$ for the canonical embedding $\text{Spec } k_{p \times \pi} C[p/d] \rightarrow C[p/d]$. For any line bundle F on $C[p/d]$, the degree of F belongs to $\frac{1}{l}\mathbb{Z}$ and we have*

$$l \deg(F) \equiv j^*(F) \in \mathbb{Z}/l\mathbb{Z},$$

where we used the canonical identification of $\text{Pic}(\text{B}\Gamma)$ with $\mathbb{Z}/l\mathbb{Z}$ of Remark 2.2.8.

Proof. Let $h \in \{0, \dots, l-1\}$ be the integer satisfying $j^*(F) = \mathbb{T}^{\otimes h}$, for \mathbb{T} the tangent space at p . The tautological line bundle M on $C[p/d]$ satisfies $M^{\otimes l} \cong \pi^* \mathcal{O}_C(p)$, (2.2.3). Note that $j^*M = \mathbb{T}$. Hence, $F \otimes (M^{\otimes h})^{\vee} = \pi^* \mathcal{O}_C(D)$ for an integral divisor D on C , and we have

$$\begin{aligned} l \deg(F) &= l \deg(M^{\otimes h} \otimes \pi^* \mathcal{O}_C(D)) \\ &= \deg(M^{\otimes hl} \otimes \pi^* \mathcal{O}_C(lD)) \\ &= \deg(\pi^* \mathcal{O}(h[p]) \otimes \pi^* \mathcal{O}_C(lD)) \\ &= \deg_C(\mathcal{O}(h[p]) \otimes \mathcal{O}_C(lD)) \\ &= h + l \deg D \\ &\equiv h \pmod{l} \\ &\equiv j^*(F) \pmod{l}. \end{aligned}$$

□

2.3 Stable curves

We recall some standard definition for sake of clarity and for preparing the definition of twisted curve in §2.4. For any integer $g \geq 2$, a *stable* curve of genus g on a scheme X is a proper and flat morphism $C \rightarrow X$ satisfying the following conditions:

1. for each point $x \in X$ the fibre C_x is reduced, connected, 1-dimensional, and has only ordinary double points (which we usually call *nodes*);
2. the dualizing sheaf of C_x is ample;
3. $\dim_{k(x)} H^1(C_x, \mathcal{O}_{C_x}) = g$.

The *dual graph* Λ of a stable curve C over k is the graph whose set of vertices V is the set of irreducible components of C and whose set of edges E is the set of nodes of C . An edge connects the vertices corresponding to the irreducible components containing the two branches of

the nodes. If an orientation of Λ is fixed, we have a chain complex $\mathcal{C}_\bullet(\Lambda, \mathbb{Z}/r\mathbb{Z})$ with differential

$$\partial: (\mathbb{Z}/r\mathbb{Z})^E \rightarrow (\mathbb{Z}/r\mathbb{Z})^V,$$

where the edge starting at v_- and ending at v_+ is sent to the 0-chain $[v_+] - [v_-]$. We say that a node e of a stable curve C is *separating* if by normalizing C at the point e we obtain two disjoint components.

If we assign to each vertex $v \in V$ the genus g_v of the connected component of the normalization of C corresponding to the irreducible component attached to v , the (arithmetic) genus of C can be read off from Λ and the function $v \mapsto g_v$. Indeed, we have

$$g(C) = b_1 + \sum_v g_v \tag{2.3.1}$$

where $b_1 = 1 - \#(V) + \#(E)$ is the first Betti number of Λ .

2.4 Twisted curves

We recall the notion of twisted curve due to Abramovich and Vistoli, see [AV02] or the remarks below for some slight generalizations.

2.4.1 Definition. A *twisted curve* of genus g on a scheme X is a proper and flat morphism of tame stacks $\mathcal{C} \rightarrow X$, for which

1. the fibres are purely 1-dimensional with at most nodal singularities,
2. the coarse space is a stable curve $|\mathcal{C}| \rightarrow X$ of genus g ;
3. the smooth locus \mathcal{C}^{sm} is an algebraic space;
4. the local picture at a node is given by $[U/\mu_l] \rightarrow T$, where
 - $T = \text{Spec } A$,
 - $U = \text{Spec } A[z, w]/(zw - t)$ for some $t \in A$, and
 - the action of μ_l is given by $(z, w) \mapsto (\xi_l z, \xi_l^{-1} w)$.

(Recall that the tameness condition on \mathcal{C} means that for every geometric point the order of the stabilizer is prime to $\text{char}(k)$.)

2.4.2 Remark (unbalanced twisted curves). In the existing literature twisted curves satisfying the above local condition (4) are often called *balanced*, [AV02]. We drop the adjective *balanced*, because we never consider unbalanced twisted curves.

2.4.3 Remark (twisted curves with smooth stack-theoretic points). A further natural generalization, which is usually given in the definition of a twisted curve (see [AV02, Def. 4.1.2]), consists of allowing nontrivial stabilizers on smooth points. By [Cad, Thm 4.1] and [Ol, Thm 1.8], giving a stack-theoretic curve with a smooth point whose stabilizer has order l is equivalent to assigning an integer l , a twisted curve $\mathcal{C} \rightarrow X$ in the sense of Definition 2.4.1, and a section $\sigma: X \rightarrow \mathcal{C}$ in the smooth locus. (With the notation introduced above, the equivalence is essentially $(\mathcal{C}, \sigma, l) \mapsto \mathcal{C}[\sigma(X)/l]$.)

2.4.4 Remark (unstable coarse space). Twisted curves are generally defined without imposing the condition of stability on the coarse space. In Olsson's paper [Ol], it is shown that these sort

of stack-theoretic curves form an algebraic stack in the sense of Artin’s definition. If we require that the coarse space $|\mathbf{C}|$ is stable, we get a Deligne–Mumford stack. See Theorem 2.4.6.

A 1-morphism $\mathbf{C} \rightarrow X$ to $\mathbf{C}' \rightarrow X'$ between twisted curves is a morphism of stacks m fitting in the fibre diagram

$$\begin{array}{ccc} \mathbf{C} & \xrightarrow{m} & \mathbf{C}' \\ \downarrow & \square & \downarrow \\ X & \longrightarrow & X'. \end{array}$$

By Lemma 2.2.1, there is at most one natural transformation, which identifies two morphisms. Therefore, we obtain a *category* by considering morphisms as 1-morphisms up to base-preserving natural transformations.

In [Ol, Thm. 1.9], Olsson proves that such a category is an algebraic stack. In particular, see [Ol, Rem. 1.10], he shows how the versal deformation space of a twisted curve $\mathbf{C} \rightarrow \text{Spec } k$ relates to the versal deformation space $\text{Spec } I$ of the coarse space $|\mathbf{C}|$. Let $\mathbf{e}_1, \dots, \mathbf{e}_n$ be the nodes of \mathbf{C} and $|\mathbf{e}_1|, \dots, |\mathbf{e}_n|$ the corresponding nodes of $|\mathbf{C}|$. Let l_i be the order of the automorphism group of \mathbf{e}_i . Let

$$D_i = \{t_i = 0\} \tag{2.4.5}$$

be the divisor classifying deformations of $|\mathbf{C}|$ on which the node $|\mathbf{e}_i|$ persists:

2.4.6 Theorem (Olsson, [Ol, Thm. 1.9]). *The category of twisted curves $\tilde{\mathbf{M}}_g$ in the sense of Definition 2.4.1 is a smooth Deligne–Mumford stack and the versal deformation space of a twisted curve $\mathbf{C} \rightarrow \text{Spec } k$ is given by*

$$\tilde{I} := I[z_1, \dots, z_m] / (z_1^{l_1} - t_1, \dots, z_m^{l_m} - t_m), \tag{2.4.7}$$

where $t_1, \dots, t_m \in I$ are the parameters satisfying (2.4.5) and l_1, \dots, l_m are the orders of the stabilizers of the corresponding nodes. \square

The group of automorphisms of a twisted curve acts naturally on the versal deformation space of a twisted curve. Using [ACV03], we describe the automorphisms of a twisted curve. Then, in Remark 2.4.10, we illustrate the action on the versal deformation.

Automorphisms of twisted curves. Let $\pi: \mathbf{C} \rightarrow |\mathbf{C}|$ be a twisted curve over k . In [ACV03, Prop. 7.1.1] the group $\text{Aut}(\mathbf{C}, |\mathbf{C}|)$ of automorphisms of \mathbf{C} that fix the coarse space $|\mathbf{C}|$ is explicitly calculated:

2.4.8 Theorem (Abramovich, Corti, Vistoli, [ACV03, Prop. 7.1.1]). *For a twisted curve over an algebraically closed field, we have an isomorphism*

$$\text{Aut}(\mathbf{C}, |\mathbf{C}|) \cong \mu_{l_1} \times \cdots \times \mu_{l_n},$$

where l_1, \dots, l_n are the orders of the automorphisms of the nodes $\mathbf{e}_1, \dots, \mathbf{e}_n$. \square

2.4.9 Remark. In fact [ACV03, Thm. 7.1.1] shows that we can choose generators $\mathbf{g}_1, \dots, \mathbf{g}_n$ of $\text{Aut}(\mathbf{C}, |\mathbf{C}|)$ such that the restriction of \mathbf{g}_i to $\mathbf{C} \setminus \{\mathbf{e}_i\}$ is the identity, and the local picture at \mathbf{e}_i

is given by

$$\begin{aligned} k[z, w]/(zw) &\rightarrow k[z, w]/(zw) \\ (z, w) &\mapsto (z, \xi_{l_i} w), \end{aligned}$$

where ξ_{l_i} is a primitive l_i th root of unity. (Local pictures are given up to natural transformations, and the 1-automorphism above is in fact, locally on the strict henselization, 2-isomorphic to $(z, w) \mapsto (\xi_{l_i}^k z, \xi_{l_i}^{1-k} w)$ for any $k = 0, \dots, l_i - 1$.)

2.4.10 Remark. The group $\text{Aut}(\mathbb{C}, |\mathbb{C}|)$, with the basis specified above, acts on the versal deformation space (2.4.7) as $(\mathbf{g}_1, \dots, \mathbf{g}_n)z_i = \xi_{l_i} z_i$ (see [Ol, Lem. 5.3]).

2.5 Line bundles on twisted curves

In view of the study of r th roots in the Picard group we review some facts on line bundles on twisted curves.

2.5.1 Proposition. *For any twisted curve $f: \mathbb{C} \rightarrow X$ with coarse space $|f|: |\mathbb{C}| \rightarrow X$ the pullback via $\pi: \mathbb{C} \rightarrow |\mathbb{C}|$ of the relative dualizing sheaf of $|f|$ is the relative dualizing sheaf of f .*

Proof. The natural homomorphism $\pi^* \omega_{|f|} \rightarrow \omega_f$ is an isomorphism on the smooth locus. At the nodes the local picture of $\mathbb{C} \rightarrow |\mathbb{C}|$ is

$$\begin{aligned} U = \text{Spec } A[z, w]/(zw - t) &\rightarrow V = \text{Spec } A[x, y]/(xy - t^l) \\ (z, w) &\mapsto (z^l, w^l) \end{aligned}$$

with the stabilizer of the node μ_l acting as $\xi_l \cdot (z, w) = (\xi_l z, \xi_l^{-1} w)$. The local generator of the relative dualizing sheaf of $|f|$ is

$$\frac{dz^l}{z^l} - \frac{dw^l}{w^l}$$

and is sent to the local generator $dz/z - dw/w$ of ω_f (recall that $d(z^l) = lz^{l-1}dz$ and $d(w^l) = lw^{l-1}dw$). \square

We now fix a twisted curve over k and describe the action by pullback of $\text{Aut}(\mathbb{C})$ on $\text{Pic}(\mathbb{C})$. We take one of the automorphisms belonging to $\text{Aut}(\mathbb{C}, \mathbb{C} \setminus \{e\}) \subseteq \text{Aut}(\mathbb{C}, |\mathbb{C}|)$ fixing the entire twisted curve away from a node e with stabilizer of order l . We describe explicitly such automorphism by choosing for the rest of this section a primitive l th root of unity ξ . The local picture of \mathbb{C} at e is given by $[V/\mu_l]$, where V equals $\{z_+ z_- = 0\}$ and μ_l acts as $(z_+, z_-) \mapsto (\xi z_+, \xi^{-1} z_-)$. The automorphism $\mathbf{g} \in \text{Aut}(\mathbb{C}, |\mathbb{C}|)$ is chosen in such a way that $\mathbb{C} \setminus \{e\}$ is fixed and the local picture at e is

$$\mathbf{g}^{\text{sh}}: (z_+, z_-) \mapsto (z_+, \xi z_-). \quad (2.5.2)$$

We already noted in Theorem 2.4.8 and Remark 2.4.9 that all automorphisms of \mathbb{C} are equal (up to natural transformation) to the composite of pullbacks from $|\mathbb{C}|$ and products of morphisms defined in the same way as \mathbf{g} .

We now take a line bundle L on C and show in Proposition 2.5.3 that pulling back L via g is the same as tensoring L by a line bundle T_L in the torsion of the Picard group of C . We need to set up some standard notation identifying the line bundle T_L .

Consider the homomorphism

$$\gamma: \mathbb{G}_m \rightarrow \text{Pic } C$$

sending $\lambda \in \mathbb{G}_m$ to the line bundle on of regular functions f on the partial normalization at the node e satisfying $f(p_+) = \lambda f(p_-)$, where p_+ and p_- are the points of the normalization lifting the node e .

Consider the pullback of L on the partial normalization, and its restriction on $B(\text{Aut}(p_+))$. We already noted in Remark 2.2.8 that the Picard group of $B(\text{Aut}(p_+))$ is canonically generated by T_{p_+} . Therefore, L determines on $B(\text{Aut}(p_+))$ a power of T_{p_+} ; we denote its exponent by

$$\text{mult}_{p_+} L \in \{0, \dots, l-1\}.$$

Note that γ and $\text{mult}_{p_+} L$ are transformed into $\lambda \mapsto \gamma(\lambda^{-1})$ and $l - \text{mult}_{p_+} L$ (reduced modulo l) if we interchange the notations p_+ and p_- . This implies that the line bundle

$$T_L = \gamma(\xi^{\text{mult}_{p_+} L}) \in \text{Pic}(C)$$

only depends on L and does not depend on the notation p_+ , p_- .

2.5.3 Proposition. *For any line bundle L on C and for $g \in \text{Aut}(C, C \setminus \{e\})$ satisfying (2.5.2) we have*

$$g^*L \cong L \otimes T_L. \quad (2.5.4)$$

□

Proof. The local picture of $L \rightarrow C$ at the point of the zero section over e is

$$W = [(V \times \mathbb{A}^1)/\mu_l] \rightarrow [V/\mu_l]$$

where V is $\{z_+z_- = 0\}$ as above, and $\xi \in \text{Aut}(e)$ acts on $((z_+, z_-), \lambda) \in V \times \mathbb{A}^1$ as

$$((z_+, z_-), t) \mapsto ((\xi z_+, \xi^{-1} z_-), \xi^{\text{mult}_{p_+} L} t). \quad (2.5.5)$$

By tensoring with a suitable element of $\pi^* \text{Pic}[C]$, we can restrict to the case of a line bundle L on C which is trivial on $C \setminus \{e\}$. In this way, for $V^\times = V \setminus (0, 0)$, we can regard L as the datum of a line bundle W on $[V/\mu_l]$ alongside with an isomorphism Φ between $W|_{V^\times}$ and the μ_l -invariant submodule of $\mathcal{O}_{V^\times} = \text{Spec } k[z_+, z_+^{-1}] \oplus \text{Spec } k[z_-, z_-^{-1}]$. By (2.5.5), the line bundle W is trivial on V and μ_l -linearized by the character $\xi \mapsto \xi^h$ for $h = \text{mult}_{p_+} L$. Note that invariant sections of $W|_{V^\times}$ form a module $z_+^{l-h} \text{Spec } k[z_+, z_+^{-1}] \oplus z_-^h \text{Spec } k[z_-, z_-^{-1}]$. Pulling back via $g: (z_+, z_-) \mapsto (z_+, \xi z_-)$ changes Φ by multiplication by $(1 \oplus \xi^h)$ in $\text{Spec } k[z_+, z_+^{-1}] \oplus \text{Spec } k[z_-, z_-^{-1}]$. In this way, we only change the descent datum along the partial desingularization at e by multiplication by ξ^h on the branch $(z_+ = 0)$. This amounts to tensoring as in (2.5.4). □

On a stable curve $C \rightarrow \text{Spec } k$, the total degree of a line bundle is the sum of the degrees on the connected components of the normalization. We extend this definition to twisted curves.

2.5.6 Proposition. *The total degree of a line bundle F on a twisted curve C over k is an integer.*

Proof. We only need to prove the claim in the case when F is trivial on $C \setminus \{e\}$ and nontrivial on the node e . Then, in order to calculate the total degree, we can regard F as a line bundle on a twisted curve C with trivial stabilizers on every node except e . The normalization of C is a smooth stack C^ν as in Example 2.2.7: $C^\nu = X[p_1/l + p_2/l]$ for $p_1, p_2 \in X$ and $l \in \mathbb{Z}_{\geq 1}$. We calculate the total degree using Proposition 2.2.10.

First, assume that the partial normalization of C at e is the disconnected stack $C^\nu = D_1 \sqcup D_2$. By Proposition 2.2.10, the total degree of F is in $\frac{1}{l}\mathbb{Z}$. We need to show that the total degrees of the restrictions F_1 and F_2 on D_1 and D_2 satisfy

$$l \deg(F_1) + l \deg(F_2) \equiv 0 \pmod{l}. \quad (2.5.7)$$

By Proposition 2.2.10, this amounts to showing that the pullbacks of F_i with respect to $\text{Spec } k_{p_i} \times_\pi D_i \rightarrow D_i$ yield inverse characters of $\text{Aut}(e)$ for $i = 1$ and 2 . This follows using the local picture given above, (2.5.5).

Finally, if the partial normalization $h: C^\nu \rightarrow C$ is connected we have two distinct points p_1 and p_2 with nontrivial stabilizer of order d lying over e . We can define two line bundles F_1 and F_2 on C^ν such that F_i is trivial at p_i , and $F_1 \otimes F_2 = h^*F$. Then, (2.5.7) holds (with the same proof) and this implies the claim. \square

3 The functor of r th roots of a line bundle

This section is divided in two sections: §3.1 and §3.2.

1. Relying on the results of [Li06] or on the appendix, this first part recalls briefly that r th roots of a line bundle form a Deligne–Mumford stack. We consider a twisted curve $C \rightarrow X$ and the functor $F^{1/r}$ of r th roots of F , a line bundle on C whose relative degree is a multiple of r . We show that it is a μ_r -gerbe over a scheme étale on X . We notice that the stack of r th roots $F^{1/r}$ is finite as soon as the geometric fibre on X is constant.
2. In Section 3.2, we study the fibre of $F^{1/r} \rightarrow X$ by calculating the cohomology of the Kummer sequence

$$1 \rightarrow \mu_r \rightarrow \mathbb{G}_m \xrightarrow{r} \mathbb{G}_m \rightarrow 1$$

for a twisted curve C over an algebraically closed field. The main result is Theorem 3.2.3, where the endomorphism $L \mapsto L^{\otimes r}$ of $\text{Pic } C$ is inscribed in a diagram of exact sequences. In Corollary 3.2.16, we apply the result to twisted curves (we draw the diagram for a twisted curve in Figure 2 at 3.2.22). Finally, in Theorem 3.2.2, we deduce the numerical criterion classifying line bundles on twisted curve having exactly r^{2g} roots. Let us record straight away a consequence of Theorem 3.2.3 in the context where r divides $\#(\text{Aut}(e))$ for every node e .

3.0.8 Corollary. *Let $\pi: C \rightarrow |C|$ be a twisted curve of genus g over k . There is an exact sequence*

$$1 \rightarrow \text{Pic}|C| \xrightarrow{\pi^*} \text{Pic } C \rightarrow \prod_{e \in E} \text{Pic } B(\text{Aut}(e)) \rightarrow 1,$$

where E is the set of nodes e in C . Furthermore, as soon as

$$\#(\text{Aut}(e)) \in r\mathbb{Z} \quad \forall e \in E$$

we can write $\prod_E \text{Pic B}(\text{Aut}(e)) \cong \mathcal{C}_1(\Lambda, \mathbb{Z}/r\mathbb{Z})$ where Λ denotes the dual graph of C and we have an exact sequence

$$1 \rightarrow (\text{Pic}|C|)_r \xrightarrow{\pi^*} (\text{Pic } C)_r \rightarrow \mathcal{C}_1(\Lambda, \mathbb{Z}/r\mathbb{Z}) \xrightarrow{\partial} \mathcal{C}_0(\Lambda, \mathbb{Z}/r\mathbb{Z}) \xrightarrow{\varepsilon} \mathbb{Z}/r\mathbb{Z} \rightarrow 1 \quad (3.0.9)$$

where $(\text{Pic}|C|)_r$ and $(\text{Pic } C)_r$ denote the r -torsion subgroups of the Picard groups, ∂ is the boundary homomorphism with respect to a chosen orientation of Λ , and ε denotes the augmentation homomorphism $(h_v)_V \mapsto \sum_V h_v \in \mathbb{Z}/r\mathbb{Z}$.

For any line bundle on $|C|$, whose total degree is a multiple of r , the pullback on C has r^{2g} r th roots. (For $(2g-2)k \in r\mathbb{Z}$, this applies in particular to $F = \omega_C^{\otimes k}$ by Proposition 2.5.1.) \square

3.1 The stack of r th roots of a line bundle

Consider the twisted curve $f: C \rightarrow X$. We write LB_f for the category of line bundles on base changes $C_S = C \times_X S$ for every X -scheme S . More precisely, the *objects* are pairs (S, M) , where S is an X -scheme and M is a line bundle on $C_S = C \times_X S$. The *morphisms* $(S, M) \rightarrow (S', M')$ are pairs (m, a) , where $m \in \text{Hom}_X(S, S')$ and a is an isomorphism of line bundles $a: M \xrightarrow{\sim} M' \times_{S'} S$ on C_S . This fibred category is an algebraic stack and indeed a substack of the fibred category of coherent sheaves, [Li06, Thm. 2.1.1, Lem. 2.3.1]. The properties of LB_f needed here are independently proven in Appendix A (Proposition A.1.2 and Remark A.1.5).

3.1.1 Remark. Note that, in this way, we can define the algebraic stack $\widetilde{\text{LB}}_g$: the category fibred on the category of twisted curves \widetilde{M}_g whose fibre on $C \rightarrow X$ is the stack LB_f .

Let F be a line bundle on C , whose relative degree is a multiple of r ; over X we have $F \rightarrow C$. Consider the category $F^{1/r}$ of r th roots of $F_S = F \times_X S$ on $C_S = C \times_X S$ for an X -scheme S . More precisely, the category is formed by the *objects* (S, M, j) , where S is an X -scheme, M is a line bundle on C_S , and j is an isomorphism $M^{\otimes r} \xrightarrow{\sim} F_S$. The *morphisms* $(S, M, j) \rightarrow (S', M', j')$ are pairs (m, a) as above, with $a^{\otimes r}$ commuting with j and j' .

3.1.2 Remark. The line bundle F can be regarded as a section $X \rightarrow \text{LB}_f$. Consider the X -morphism $k_r: \text{LB}_f \rightarrow \text{LB}_f$ defined by $(S, M) \mapsto (S, M^{\otimes r})$ and $(m, a) \mapsto (m, a^{\otimes r})$. In this way, we can equivalently define $F^{1/r}$ as the fibre product

$$F^{1/r} = (\text{LB}_f)_{k_r \times_F X}.$$

3.1.3 Proposition. *The category $F^{1/r}$ satisfies the following properties.*

- I. *It is a Deligne–Mumford stack, étale over X .*
- II. *If $F = \mathcal{O}$, it is a group stack on X .*
- III. *For any F the functor*

$$\begin{aligned} m: \mathcal{O}^{1/r} \times_X F^{1/r} &\rightarrow F^{1/r} \\ (N, j), (M, k) &\mapsto (N \otimes M, j \otimes k) \end{aligned}$$

is an action of $\mathcal{O}^{1/r}$ on $F^{1/r}$, and $(m \times \text{pr}_2): \mathcal{O}^{1/r} \times_X F^{1/r} \rightarrow F^{1/r} \times_X F^{1/r}$ is an isomorphism of stacks.

Proof. Using [Li06] or Appendix A, the proof of the fact that $F^{1/r}$ is of Deligne–Mumford type only amounts to showing that the diagonal is unramified (the category of algebraic stacks is closed under fibred products [LM00, 4.5]). We show that the fibre of the morphism $\text{Isom}_S(\alpha, \beta) \rightarrow S$ is reduced. Indeed, at each point s of S the fibre is either empty, if $M_{\alpha,s} \not\cong M_{\beta,s}$, or represented by the reduced group scheme $\mu_r(k)$, if $M_{\alpha,s} \cong M_{\beta,s}$ (the group scheme $\mu_r(k)$ acts transitively and freely by multiplication along the fibres of the line bundle).

Finally the étaleness of $F^{1/r} \rightarrow X$ claimed in part (I) follows from the fact that the relative cotangent complex vanishes. Indeed, as shown in [ACV03, Prop. 3.0.2] and [AJ03, §2.1], this is a consequence of the fact that the relative cotangent complex \mathbb{L}_{k_r} vanishes.

Part (II) follows from the fact that the stack $\mathcal{O}^{1/r}$ is a functor sending each X -scheme S to the groupoid of r -torsion line bundles on C_S . In fact such a groupoid is a Picard category: a symmetric monoid where each object is invertible and the functors

$$\begin{aligned} \mathcal{O}^{1/r} \times_X \mathcal{O}^{1/r} &\rightarrow \mathcal{O}^{1/r} & X &\rightarrow \mathcal{O}^{1/r} & \mathcal{O}^{1/r} &\rightarrow \mathcal{O}^{1/r} \\ (S, (M_1, j_1), (M_2, j_2)) &\mapsto (S, M_1 \otimes M_2, j_1 \otimes j_2) & S &\mapsto (S, \mathcal{O}, \text{id}) & (S, M, j) &\mapsto (S, M^\vee, j^\vee) \end{aligned}$$

satisfy the law of associativity, the law of the identity, and the law of the inverse.

Part (III) holds because the inverse of the morphism $m \times \text{pr}_2$ is given by the functor $(S, (M_1, k_1), (M_2, k_2)) \mapsto (S, (M_1 \otimes M_2^\vee, k_1 \otimes (k_2^\vee)^{-1}), (M_1, k_2))$. \square

3.1.4 Definition (the functor $\overline{F^{1/r}}$). Note that each object (S, M, j) of $F^{1/r}$ over an X -scheme S has automorphisms given by multiplication by an r th root of unity along the fibre of L . We can eliminate these automorphisms by passing to the corresponding rigidified stack (the general setting is recalled in §A.2). The stack $\overline{F^{1/r}}$ is the rigidification of $F^{1/r}$ along μ_r in the sense of Theorem A.2.1:

$$\overline{F^{1/r}} = (F^{1/r})^{\mu_r}.$$

3.1.5 Proposition. *The morphism $\overline{F^{1/r}} \rightarrow X$ is represented by an étale scheme on X , whose fibre on a point $x \in X$ is*

$$\{\alpha \in \text{Pic}(C_x) \mid \alpha^r = [F_x]\}.$$

Assume that F is the trivial line bundle \mathcal{O} of C ; then, $\overline{\mathcal{O}^{1/r}}$ is a group scheme.

Proof. The morphism $F^{1/r} \rightarrow X$ is étale, Proposition 3.1.3. The morphism $F^{1/r} \rightarrow \overline{F^{1/r}}$, is surjective and indeed an étale morphism “locally isomorphic” to $\mathbf{B}\mu_r$ on $\overline{F^{1/r}}$ (see [Ro, I. Prop. 3.0.2, (2)] and [ACV03, Thm. 5.1.5]). Therefore, $\overline{F^{1/r}} \rightarrow X$ is étale.

Finally $\overline{F^{1/r}} \rightarrow X$ is representable because for any algebraically closed field K and any $\tau \in \overline{F^{1/r}}(\text{Spec } K)$ the automorphism group of τ is trivial (this condition suffices by a criterion due to Abramovich and Vistoli, [AV02, Lem. 4.4.3]). Indeed, the objects of $\overline{F^{1/r}} = (F^{1/r})^{\mu_r}$ over an algebraically closed field K are the same as the objects of $F^{1/r}$ over K . Now, the automorphism group of the μ_r -rigidified object τ is the quotient by $\mu_r(K)$ of the automorphism group of τ in $F^{1/r}$, Theorem A.2.1, (3). This quotient can be easily seen to be trivial: note that

$\mu_r(K) \rightarrow \text{Aut}(\tau)$ is surjective, because an automorphism of an r th root $(M, j: M^{\otimes r} \xrightarrow{\sim} F)$ on a twisted curve $C \rightarrow \text{Spec } K$

$$a: M \xrightarrow{\sim} M \quad a^{\otimes r} \circ j = j$$

necessarily satisfies $a^{\otimes r} = \text{id}$ and, since $C \otimes K$ is connected, a is given by the multiplication by an r th root of unity along the fibre of M .

The rest of the proposition follows immediately from Proposition 3.1.3 (the group structure and the action of $\mathcal{O}^{1/r}$ on $F^{1/r}$ descend to $\overline{F^{1/r}}$ and their relations are preserved). \square

3.1.6 Proposition. *Assume that the data $F \rightarrow C \rightarrow X$ satisfy the following conditions: $F^{1/r}$ has degree r^{2g} on X and for any closed point $x \in X$ the line bundle F_x has r^{2g} r th roots on C_x up to isomorphism. Then, we have the following properties.*

(1) $\overline{\mathcal{O}^{1/r}}$ is a finite group scheme and $\overline{F^{1/r}}$ is a finite torsor under $\overline{\mathcal{O}^{1/r}}$.

(1') $\mathcal{O}^{1/r}$ is a finite group stack and $F^{1/r}$ is a finite torsor under $\mathcal{O}^{1/r}$.

Proof. The morphism $p: Y = \overline{F^{1/r}} \rightarrow X$ is étale and the fibre on each point is reduced and is the union of $n = r^{2g}$ distinct points. This condition is sufficient for the properness of p : indeed it implies that p is an isomorphism when n equals 1, and it implies properness by induction on the degree (we can check properness after an étale base change, and we note that $Y \times_X Y$ is finite on Y because $(Y \times_X Y) \setminus \Delta(X)$ is étale on Y , and has constant reduced fibre consisting of $n - 1$ points).

Now, note that if F_x has r^{2g} distinct r th roots on C_x , then the structure sheaf of C_x also has r^{2g} distinct roots. Therefore, $\overline{\mathcal{O}^{1/r}}$ is a finite group and $\overline{F^{1/r}}$ is a finite torsor under $\overline{\mathcal{O}^{1/r}}$, because the geometric fibres of $\overline{F^{1/r}} \rightarrow X$ are nonempty, and $\overline{\mathcal{O}^{1/r}} \times_X \overline{F^{1/r}} \rightarrow \overline{F^{1/r}} \times_X \overline{F^{1/r}}$ is an isomorphism. Finally the point (1') follows from Proposition 3.1.3, and the fact that $F^{1/r}$ is proper on $\overline{F^{1/r}}$. \square

3.2 The Kummer theory of a twisted curve

Since, by the above proposition, $F^{1/r}$ is finite as soon as the fibre is constant, we focus on the fibres of $\overline{F^{1/r}} \rightarrow X$ on closed points $\text{Spec } k \rightarrow X$.

3.2.1 Notation (multiplicity of a line bundle at a smooth stack-theoretic point). We consider 1-dimensional Deligne–Mumford stacks X with nodal singularities and trivial stabilizers except for a finite number of points. As noted in Remark 2.2.8 for each smooth point \mathfrak{p} there is a canonical embedding

$$j: \mathbb{B}(\text{Aut}(\mathfrak{p})) \rightarrow C$$

and a canonical generator of $\text{Pic } \mathbb{B}(\text{Aut}(\mathfrak{p}))$ induced by the $\text{Aut}(\mathfrak{p})$ -linearized tangent space T . With such a canonical generator, the group $\text{Pic } \mathbb{B}(\text{Aut}(\mathfrak{p}))$ can be regarded as $\mathbb{Z}/\#(\text{Aut}(\mathfrak{p}))\mathbb{Z}$. Then for any line bundle F at any smooth point \mathfrak{p} of X we define a multiplicity index

$$0 \leq \text{mult}_{\mathfrak{p}} F \leq \#(\text{Aut}(\mathfrak{p})) - 1$$

via the pullback homomorphism

$$\text{Pic } X \xrightarrow{j^*} \text{Pic } \mathbb{B}(\text{Aut}(\mathfrak{p})).$$

If e is a node the notation $\text{mult}_e F$ does not make sense, because there is no canonical generator for $\text{Pic } \mathbf{B}(\text{Aut}(\mathfrak{p}))$. Instead, we will consider the pullback of F on the normalization, which is smooth, 1-dimensional, and contains two distinct geometric points \mathfrak{p}_1 and \mathfrak{p}_2 lying over the node e . By a slight abuse of notation we shall write $\text{mult}_{\mathfrak{p}_1} F$ and $\text{mult}_{\mathfrak{p}_2} F$ for the multiplicity index at \mathfrak{p}_1 and \mathfrak{p}_2 of the pullback of F on the normalization.

3.2.2 Theorem. *Let $C \rightarrow \text{Spec } k$ be a twisted curve with stabilizer of order $l(e)$ on each node e . Let F be a line bundle on C whose total degree is a multiple of r . The number of r th roots of F is r^{2g} if and only if for each node e we have $\eta(e) = r$, where η is the function*

$$\eta(e) = \begin{cases} \text{hcf}\{l(e), m_1(e), m_2(e), r\} & \text{if the normalization of } C \text{ at } e \text{ is the connected stack } C_0 \\ & \text{with } \mathfrak{p}_1 \text{ and } \mathfrak{p}_2 \in C_0 \text{ mapping to } e \text{ and } m_i(e) = \text{mult}_{\mathfrak{p}_i}(F); \\ \text{hcf}\{d_1(e)l(e), d_2(e)l(e), r\} & \text{if the normalization of } C \text{ at } e \text{ is } C_1 \sqcup C_2 \\ & \text{and } d_i \in (1/l(e))\mathbb{Z} \text{ is the total degree of } F \text{ on the curve } C_i. \end{cases}$$

In particular, for any line bundle on $|C|$, whose total degree is a multiple of r , there are exactly r^{2g} roots of the pullback on C if and only if r divides $l(e)$ for each nonseparating node, and r divides $l(e)d_i(e)$ for each separating node.

We prove the above criterion at the end of the section (3.2.22). The main tool is the exactness of the following diagram (Figure 1) and its interpretation for twisted curves (3.2.22, Figure 2).

3.2.3 Theorem. *Let $\pi: X \rightarrow |\mathbf{X}|$ be a tame and proper Deligne–Mumford stack of dimension 1 and assume that $\text{Aut}(\mathfrak{p})$ is trivial except for a finite number of points $\mathfrak{p}_i: \text{Spec } k \rightarrow X$. We write $\Gamma_i = \text{Aut}(\mathfrak{p}_i)$ and we denote by j the canonical embedding $\sqcup_i \mathbf{B}\Gamma_i \rightarrow X$.*

Then, the direct images $R\pi_\boldsymbol{\mu}_r$ and $R\pi_*\mathbb{G}_m$ are represented by complexes on $|\mathbf{X}|$ fitting in the exact sequences*

$$1 \rightarrow \boldsymbol{\mu}_r \rightarrow R\pi_*\boldsymbol{\mu}_r \rightarrow R\pi_*\boldsymbol{\mu}_r/\boldsymbol{\mu}_r \rightarrow 1, \quad (3.2.4)$$

$$1 \rightarrow \mathbb{G}_m \rightarrow R\pi_*\mathbb{G}_m \rightarrow R\pi_*\mathbb{G}_m/\mathbb{G}_m \rightarrow 1. \quad (3.2.5)$$

The long exact sequence of hypercohomology of (3.2.4) yields

$$1 \rightarrow H^1(|\mathbf{X}|, \boldsymbol{\mu}_r) \rightarrow H^1(X, \boldsymbol{\mu}_r) \rightarrow \prod_i H^1(\Gamma_i, \boldsymbol{\mu}_r) \xrightarrow{\delta} H^2(|\mathbf{X}|, \boldsymbol{\mu}_r) \rightarrow H^2(X, \boldsymbol{\mu}_r) \rightarrow \prod_i H^2(\Gamma_i, \boldsymbol{\mu}_r) \rightarrow 1,$$

and the long exact sequence of hypercohomology of (3.2.5) in degree 1 yields

$$1 \rightarrow \text{Pic}|\mathbf{X}| \xrightarrow{\pi^*} \text{Pic } X \rightarrow \prod_i \text{Pic}(\mathbf{B}\Gamma_i) \rightarrow 1$$

Both exact sequences above fit in the following commutative diagram (see the second and the third columns), where all vertical and horizontal sequences are exact

$$\begin{array}{cccccccc}
\text{Pic } |\mathbf{X}| & \longrightarrow & H^2(|\mathbf{X}|, \boldsymbol{\mu}_r) & \longrightarrow & 1 & \longrightarrow & 1 & \longrightarrow & 1 & \longrightarrow & 1 \\
\uparrow & & \uparrow \delta & & \uparrow & & \uparrow & & \uparrow & & \uparrow \\
1 & \longrightarrow & \prod H^1(\Gamma_i, \boldsymbol{\mu}_r) & \longrightarrow & \prod \text{Pic}(\text{B}\Gamma_i) & \xrightarrow{r} & \prod \text{Pic}(\text{B}\Gamma_i) & \longrightarrow & \prod H^2(\Gamma_i, \boldsymbol{\mu}_r) & \longrightarrow & 1 \\
\uparrow & & \uparrow & & \uparrow j^* & & \uparrow j^* & & \uparrow & & \uparrow \\
1 & \longrightarrow & H^1(\mathbf{X}, \boldsymbol{\mu}_r) & \longrightarrow & \text{Pic } \mathbf{X} & \xrightarrow{r} & \text{Pic } \mathbf{X} & \longrightarrow & H^2(\mathbf{X}, \boldsymbol{\mu}_r) & \longrightarrow & 1 \\
\uparrow & & \uparrow & & \uparrow \pi^* & & \uparrow \pi^* & & \uparrow & & \uparrow \\
1 & \longrightarrow & H^1(|\mathbf{X}|, \boldsymbol{\mu}_r) & \longrightarrow & \text{Pic } |\mathbf{X}| & \xrightarrow{r} & \text{Pic } |\mathbf{X}| & \longrightarrow & H^2(|\mathbf{X}|, \boldsymbol{\mu}_r) & \longrightarrow & 1 \\
\uparrow & & \uparrow & & \uparrow & & \uparrow & & \uparrow \delta & & \uparrow \\
1 & \longrightarrow & 1 & \longrightarrow & 1 & \longrightarrow & 1 & \longrightarrow & \prod H^1(\Gamma_i, \boldsymbol{\mu}_r) & \longrightarrow & \prod \text{Pic}(\text{B}\Gamma_i)
\end{array}$$

Figure 1: the diagram can be regarded as a double complex $K^{\bullet, \bullet}$ periodic of period $(3, -3)$.

Proof. The exactness of $1 \rightarrow \boldsymbol{\mu}_r \rightarrow \mathbb{G}_m \rightarrow \mathbb{G}_m \rightarrow 1$ holds in the étale topology of \mathbf{X} by the same argument of [Mi80, II.2.18b]. Our goal is to compare the long exact sequences of cohomology of the Kummer sequence of \mathbf{X} and of $|\mathbf{X}|$

We show that there are three complexes on $|\mathbf{X}|$ representing the direct images in the derived category $R\pi_*\boldsymbol{\mu}_r$, $R\pi_*\mathbb{G}_m$, and $R\pi_*\mathbb{G}_m$ and fitting in a short exact sequence as follows

$$1 \rightarrow R\pi_*\boldsymbol{\mu}_r \rightarrow R\pi_*\mathbb{G}_m \rightarrow R\pi_*\mathbb{G}_m \rightarrow 1. \quad (3.2.6)$$

Indeed, in the category of sheaves of abelian groups on $|\mathbf{X}|$, we can consider three injective resolutions

$$\begin{aligned}
\boldsymbol{\mu}_r &\rightarrow I_1^\bullet, \\
\mathbb{G}_m &\rightarrow I_2^\bullet, \\
\mathbb{G}_m &\rightarrow I_3^\bullet,
\end{aligned}$$

fitting in

$$\begin{array}{ccccccc}
1 & \longrightarrow & I_1^\bullet & \longrightarrow & I_2^\bullet & \longrightarrow & I_3^\bullet & \longrightarrow & 1 \\
& & \uparrow & & \uparrow & & \uparrow & & \\
1 & \longrightarrow & \boldsymbol{\mu}_r & \longrightarrow & \mathbb{G}_m & \xrightarrow{r} & \mathbb{G}_m & \longrightarrow & 1,
\end{array}$$

where all the horizontal sequences are exact (note that this happens because the category of sheaves of abelian groups has enough injectives, and, given the injective resolutions I_1^\bullet and I_3^\bullet , we can also find a third injective resolution I_2^\bullet making all horizontal sequences exact). Now, applying the direct image via $\pi: \mathbf{X} \rightarrow |\mathbf{X}|$ to $1 \rightarrow I_1^\bullet \rightarrow I_2^\bullet \rightarrow I_3^\bullet \rightarrow 1$, we get the short exact sequence (3.2.6), because all the sheaves involved are injective.

The sequence (3.2.6) allows the comparison of the long exact cohomology sequences attached to the Kummer sequences of \mathbf{X} and of $|\mathbf{X}|$. Indeed, we show that the Kummer sequence of $|\mathbf{X}|$ injects in (3.2.6). We have $\pi_*\boldsymbol{\mu}_r = \boldsymbol{\mu}_r$ and $\pi_*\mathbb{G}_m = \mathbb{G}_m$, because $\pi_*\mathcal{O}_{\mathbf{X}}$ is canonically

isomorphic to $\mathcal{O}_{|C|}$ by Keel and Mori's theorem [KM97], and the isomorphism yields the identity $\pi_*\mu_r = \mu_r$ because it identifies the r th roots of unity. We deduce that, on $|X|$, the sequence $1 \rightarrow \mu_r \rightarrow \mathbb{G}_m \rightarrow \mathbb{G}_m \rightarrow 1$ injects into (3.2.6). Therefore, we write

$$\begin{array}{ccccccc} 1 & \longrightarrow & R\pi_*\mu_r & \longrightarrow & R\pi_*\mathbb{G}_m & \xrightarrow{r} & R\pi_*\mathbb{G}_m \longrightarrow 1 \\ & & \uparrow & & \uparrow & & \uparrow \\ 1 & \longrightarrow & \mu_r & \longrightarrow & \mathbb{G}_m & \xrightarrow{r} & \mathbb{G}_m \longrightarrow 1 \\ & & \uparrow & & \uparrow & & \uparrow \\ & & 1 & & 1 & & 1 \end{array} \quad (3.2.7)$$

Note that, each vertical sequence in the diagram above is of the form $\pi_*J \rightarrow R\pi_*J$, where, on the one hand, π_*J is concentrated in degree 0: $(1 \rightarrow A^0 \rightarrow 1 \rightarrow 1 \rightarrow \dots)$, on the other hand $R\pi_*J$ is $(1 \rightarrow B^0 \rightarrow B^1 \rightarrow B^2 \dots)$ and the morphism of complexes is given by

$$\begin{array}{ccccccc} 1 & \longrightarrow & B^0 & \longrightarrow & B^1 & \longrightarrow & B^2 \\ & & \uparrow & & \uparrow & & \uparrow \\ 1 & \longrightarrow & A^0 & \longrightarrow & 1 & \longrightarrow & 1 \end{array} \quad ,$$

where $A^0 \rightarrow B^0$ is injective. By taking quotients, we get complexes representing $R\pi_*J/\pi_*J$ for $J = \mu_r$ or \mathbb{G}_m . By the exactness of the horizontal sequences in (3.2.7), we get the following diagram where horizontal and vertical sequences are exact.

$$\begin{array}{ccccccc} & & 1 & & 1 & & 1 \\ & & \uparrow & & \uparrow & & \uparrow \\ 1 & \longrightarrow & R\pi_*\mu_r/\mu_r & \longrightarrow & R\pi_*\mathbb{G}_m/\mathbb{G}_m & \longrightarrow & R\pi_*\mathbb{G}_m/\mathbb{G}_m \longrightarrow 1 \\ & & \uparrow & & \uparrow & & \uparrow \\ 1 & \longrightarrow & R\pi_*\mu_r & \longrightarrow & R\pi_*\mathbb{G}_m & \xrightarrow{r} & R\pi_*\mathbb{G}_m \longrightarrow 1 \\ & & \uparrow & & \uparrow & & \uparrow \\ 1 & \longrightarrow & \mu_r & \longrightarrow & \mathbb{G}_m & \xrightarrow{r} & \mathbb{G}_m \longrightarrow 1 \\ & & \uparrow & & \uparrow & & \uparrow \\ & & 1 & & 1 & & 1 \end{array} \quad (3.2.8)$$

We calculate the hypercohomology groups of $|X|$ with respect to the complexes \mathbb{G}_m , μ_r , $R\pi_*\mathbb{G}_m$, $R\pi_*\mu_r$, $R\pi_*\mathbb{G}_m/\mathbb{G}_m$, and $R\pi_*\mu_r/\mu_r$ in the diagram above. Since the hypercohomology groups coincide with the cohomology groups when the complex is concentrated in degree 0, for any sheaf E on $|X|$ we have

$$\mathbb{H}^j(|X|, E) = H^j(|X|, E). \quad (3.2.9)$$

By the Leray spectral sequence, for any sheaf of groups J on X , we have

$$\mathbb{H}^j(|X|, R\pi_*J) = H^j(X, J). \quad (3.2.10)$$

Finally the spectral sequence $E_2^{p,q} = H^p(|X|, H^q(R\pi_*J/\pi_*J))$ abuts to $\mathbb{H}^{p+q}(|X|, R\pi_*J/\pi_*J)$. The sheaf $H^q(R\pi_*J/\pi_*J)$ is equal to $R^q\pi_*J$ for $q > 0$, and vanishes otherwise. We now notice that $R^q\pi_*J$ is supported on the points with nontrivial stabilizer. Indeed, it is shown in [ACV03, Prop. A.0.1] that the stalk of $R^q\pi_*J$ at a point $|p| \in |X|$ is canonically isomorphic to the q th

cohomology group $H^q(\text{Aut}(\mathfrak{p}), \mathbb{J}_{\mathfrak{p}})$. Therefore, we have

$$\mathbb{H}^j(|\mathcal{X}|, R\pi_*\mathbb{J}/\pi_*\mathbb{J}) = \begin{cases} 0 & \text{if } j = 0 \\ \prod_i H^j(\Gamma_i, \mathbb{J}_{\mathfrak{p}_i}) & \text{if } j > 0, \end{cases} \quad (3.2.11)$$

because $R^q\pi_*\mathbb{J}$ is supported on the points $|\mathfrak{p}_i|$, and the differentials of $E_2^{p,q}$ vanish.

Passing to the long exact hypercohomology sequences in all directions in the diagram (3.2.8), we get the following diagram. The fact that the diagram (3.2.8) commutes implies that all the squares below commute except for the squares involving the boundary homomorphisms that anticommute. However, note that all the composition of homomorphism in the squares involving the boundary homomorphisms are trivial, so the following diagram is commutative

$$\begin{array}{cccccccccccc} H^1(|\mathcal{X}|, \mathbb{G}_m) & \rightarrow & H^2(|\mathcal{X}|, \boldsymbol{\mu}_r) & \longrightarrow & 1 & \longrightarrow & 1 & \longrightarrow & 1 & \longrightarrow & 1 \\ \uparrow & & \delta \uparrow & & \uparrow & & \uparrow & & \uparrow & & \uparrow \\ 1 & \longrightarrow & \prod H^1(\Gamma_i, \boldsymbol{\mu}_r) & \rightarrow & \prod H^1(\Gamma_i, \mathbb{G}_m) & \rightarrow & \prod H^1(\Gamma_i, \mathbb{G}_m) & \rightarrow & \prod H^2(\Gamma_i, \boldsymbol{\mu}_r) & \longrightarrow & 1 \\ \uparrow & & \uparrow & & \uparrow & & \uparrow & & \uparrow & & \uparrow \\ 1 & \longrightarrow & H^1(\mathcal{X}, \boldsymbol{\mu}_r) & \longrightarrow & H^1(\mathcal{X}, \mathbb{G}_m) & \longrightarrow & H^1(\mathcal{X}, \mathbb{G}_m) & \longrightarrow & H^2(\mathcal{X}, \boldsymbol{\mu}_r) & \longrightarrow & 1 \\ \uparrow & & \uparrow & & \uparrow & & \uparrow & & \uparrow & & \uparrow \\ 1 & \longrightarrow & H^1(|\mathcal{X}|, \boldsymbol{\mu}_r) & \longrightarrow & H^1(|\mathcal{X}|, \mathbb{G}_m) & \longrightarrow & H^1(|\mathcal{X}|, \mathbb{G}_m) & \longrightarrow & H^2(|\mathcal{X}|, \boldsymbol{\mu}_r) & \longrightarrow & 1 \\ \uparrow & & \uparrow & & \uparrow & & \uparrow & & \delta \uparrow & & \uparrow \\ 1 & \longrightarrow & 1 & \longrightarrow & 1 & \longrightarrow & 1 & \longrightarrow & \prod H^1(\Gamma_i, \boldsymbol{\mu}_r) & \rightarrow & \prod H^1(\Gamma_i, \mathbb{G}_m). \end{array}$$

In the diagram above, we used the following facts.

1. For any proper stack \mathcal{Y} the r th power homomorphism is surjective in $H^0(\mathcal{Y}, \mathbb{G}_m)$.
2. The coarse space $|\mathcal{X}|$ is a 1-dimensional scheme, therefore $H^2(|\mathcal{X}|, \mathbb{G}_m) = 1$.
3. For $j > 0$, the cohomology groups of $\Gamma_i = \text{Aut}(\mathfrak{p}_i)$ with coefficient in $(\mathbb{G}_m)_{\mathfrak{p}_i} = \mathbb{G}_m$ with a trivial Γ_i -action are given by

$$H^j(\Gamma_i, \mathbb{G}_m) = \begin{cases} 1 & \text{if } j \text{ is even,} \\ \mathbb{Z}/l(i)\mathbb{Z} & \text{if } j \text{ is odd,} \end{cases}$$

where $l(i) = \#(\Gamma_i)$.

After the identifications of $H^1(\mathcal{Y}, \mathbb{G}_m)$ with $\text{Pic}(\mathcal{Y})$, this shows the exactness of the diagram of Figure 1. \square

3.2.12 Remark (the boundary homomorphism δ). We show that the coboundary homomorphism

$$\delta: \prod_i H^1(\Gamma_i, \boldsymbol{\mu}_r) \rightarrow H^2(|\mathcal{X}|, \boldsymbol{\mu}_r)$$

which maps vertically in the commutative diagram of Figure 1 can be explicitly computed.

is an isomorphism. In fact, by construction, the coboundary homomorphism δ coincides with the composite of $K^{0,2} \rightarrow \text{coker}(d''(0,1))$ and $'d_3$. The definition of the differential $'d_3$ for the spectral sequence $'E_3^{p,q}$ yields the equations (3.2.14) above.

In the following corollary we apply Theorem 3.2.3 and the explicit computation of the boundary homomorphism δ given above to the case of a twisted curve. See also 3.2.22, Figure 2 where we summarize the result.

3.2.16 Corollary. *Let $\pi: C \rightarrow |C|$ be a twisted curve. Write $\Gamma_e = \text{Aut}(e)$ for any node $e \in E$ and $l(e)$ for its order. We have a canonical isomorphisms*

$$H^2(C, \boldsymbol{\mu}_r) \cong H^2(|C|, \boldsymbol{\mu}_r) \cong (\mathbb{Z}/r\mathbb{Z})^V. \quad (3.2.17)$$

Choose an orientation of the dual graph of C ; then, we have a canonical isomorphism identifying $H^1(\Gamma_e, \boldsymbol{\mu}_r)$ with the r -torsion of $\mathbb{Z}/l(e)\mathbb{Z}$:

$$H^1(\Gamma_e, \boldsymbol{\mu}_r) \cong (l(e)/\text{hcf}\{l(e), r\})\mathbb{Z}/l(e)\mathbb{Z} \quad \forall e. \quad (3.2.18)$$

With respect to these identifications, the homomorphism $\delta: \prod_e H^1(\Gamma_e, \boldsymbol{\mu}_r) \rightarrow H^2(|C|, \boldsymbol{\mu}_r)$ in Figure 1 is the composite homomorphism of the boundary of the chain complex $\mathcal{C}_\bullet(\Lambda, \mathbb{Z}/r\mathbb{Z})$ of the dual graph Λ of C and of the homomorphism $\prod_e H^1(\Gamma_e, \boldsymbol{\mu}_r) \rightarrow (\mathbb{Z}/r\mathbb{Z})^E$ given by the product over E of

$$(l(e)/\text{hcf}\{l(e), r\})\mathbb{Z}/l(e)\mathbb{Z} \xrightarrow{\times(r/l(e))} (r/\text{hcf}\{l(e), r\})\mathbb{Z}/r\mathbb{Z} \hookrightarrow \mathbb{Z}/r\mathbb{Z} \quad \forall e.$$

Proof. First, we see the preliminary case of the stack $C[p/l]$. Then, we normalize the twisted curve and use the presentation of smooth 1-dimensional stacks given in Section 2.2.7.

3.2.19 Lemma. *Let C be a proper, connected, smooth, and reduced curve over k . For $p \in C$ consider the stack $C[p/l]$: the point $C[p/l]$ over $p \in C$ has automorphism group Γ of order l . The boundary homomorphism δ of Figure 1 is the composite homomorphism*

$$H^1(\text{B}\Gamma, \boldsymbol{\mu}_r) \cong (l/\text{hcf}\{l, r\})\mathbb{Z}/l\mathbb{Z} \xrightarrow{\times(r/l)} (r/\text{hcf}\{l, r\})\mathbb{Z}/r\mathbb{Z} \hookrightarrow \mathbb{Z}/r\mathbb{Z} \cong H^2(C, \boldsymbol{\mu}_r),$$

where we used the canonical isomorphisms $\text{Pic}(\text{B}\Gamma) \cong \mathbb{Z}/l\mathbb{Z}$ (Remark 2.2.8) and $H^2(C, \boldsymbol{\mu}_r) \cong \mathbb{Z}_l/r\mathbb{Z}$.

Proof. As in Remark 2.2.8, we denote by \mathbb{T} the tangent space at \mathfrak{p} . Now, we apply to $\mathbb{T}^{\otimes m} \in H^1(\Gamma, \boldsymbol{\mu}_r)$ the definition of δ given in (3.2.14). Let \mathbb{M} be a line bundle on $C[p/l]$ such that $j^*\mathbb{M} = \mathbb{T}^{\otimes m}$; let A be a line bundle on C , such that $\pi^*A = \mathbb{M}^{\otimes r}$. Then, $\delta(\mathbb{T}^{\otimes m})$ is $\text{deg } A \pmod{r}$. Finally, by Proposition 2.2.10, we have

$$\text{deg}(A) = \text{deg}(\mathbb{M}^{\otimes r}) = r \text{deg}(\mathbb{M}) = r(k + m/l) = rk + mr/l.$$

This is indeed the claim of the lemma. □

Now let $D \rightarrow C$ and $|D| \rightarrow |C|$ be the normalization of C and $|C|$. Note that D has trivial stabilizers except for a finite set of smooth points I . Therefore, Theorem 3.2.3 applies. Furthermore,

for any point $\mathfrak{p} \in \mathbb{D}$ with $|\text{Aut}(\mathfrak{p})| = l > 1$, there is a natural projection

$$\mathbb{D} \rightarrow |\mathbb{D}|[|\mathfrak{p}|/l]. \quad (3.2.20)$$

Using Lemma 3.2.19, we get a canonical isomorphism $H^1(\text{Aut}(\mathfrak{p}), \boldsymbol{\mu}_r) \cong (l/\text{hcf}\{l, r\})\mathbb{Z}/l\mathbb{Z}$ and a homomorphism

$$H^1(\text{Aut}(\mathfrak{p}), \boldsymbol{\mu}_r) \xrightarrow{\times(r/l)} H^2(|\mathbb{D}|, \boldsymbol{\mu}_r). \quad (3.2.21)$$

Note that the morphism $\delta_{\mathbb{D}}: \prod_{\mathfrak{p} \in I} H^1(\text{Aut}(\mathfrak{p}), \boldsymbol{\mu}_r) \rightarrow H^2(|\mathbb{D}|, \boldsymbol{\mu}_r)$ coincides with (3.2.21) on each factor, because δ commutes with pullbacks via the projections (3.2.20).

Now, consider $\mathbb{D} \rightarrow \mathbb{C}$. For each node \mathfrak{e} of \mathbb{C} there are two smooth points $\mathfrak{p}_{\mathfrak{e},+}, \mathfrak{p}_{\mathfrak{e},-} \in \mathbb{D}$ over \mathfrak{e} with stabilizer $\Gamma_{\mathfrak{e}}$, we denote them according to the orientation of the dual graph. Now, $H^1(\Gamma_{\mathfrak{e}}, \boldsymbol{\mu}_r)$ is the r -torsion subgroup of $H^1(\Gamma_{\mathfrak{e}}, \mathbb{G}_m)$, which is canonically generated by the tangent space $\mathbb{T}_{\mathfrak{e},+}$ at the point of $\mathfrak{p}_{\mathfrak{e},+} \in \mathbb{D}$. Thus, by raising $\mathbb{T}_{\mathfrak{e},+}$ to the $(l(\mathfrak{e})/\text{hcf}\{l(\mathfrak{e}), r\})$ th power, we get the canonical isomorphism (3.2.18).

The cohomology homomorphisms induced by pullback via $\mathbb{D} \rightarrow \mathbb{C}$ are compatible with the diagrams of Figure 1 for \mathbb{C} and \mathbb{D} . Now,

$$\delta_{\mathbb{C}}: \prod_{\mathfrak{e}} H^1(\Gamma_{\mathfrak{e}}, \boldsymbol{\mu}_r) \rightarrow H^2(|\mathbb{C}|, \boldsymbol{\mu}_r)$$

fits in the following commutative diagram

$$\begin{array}{ccc} \prod_{\mathfrak{e}} H^1(\Gamma_{\mathfrak{e}}, \boldsymbol{\mu}_r) & \xrightarrow{\delta_{\mathbb{C}}} & H^2(|\mathbb{C}|, \boldsymbol{\mu}_r) \\ \prod_{\mathfrak{e}} g_{\mathfrak{e}} \downarrow & & \downarrow \cong \\ \prod_{\mathfrak{e}, i=+,-} H^1(\text{Aut}(\mathfrak{p}_{\mathfrak{e},i}), \boldsymbol{\mu}_r) & \xrightarrow{\delta_{\mathbb{D}}} & H^2(|\mathbb{D}|, \boldsymbol{\mu}_r), \end{array}$$

where the homomorphism induced via pullback $H^2(|\mathbb{D}|, \boldsymbol{\mu}_r) \rightarrow H^2(|\mathbb{C}|, \boldsymbol{\mu}_r)$ is invertible and the morphisms $g_{\mathfrak{e}}$ are induced by pullback via $\mathbb{D} \rightarrow \mathbb{C}$ and map as

$$\mathbb{T}_{\mathfrak{e},+} \rightarrow (\mathbb{T}_{\mathfrak{e},+}, (\mathbb{T}_{\mathfrak{e},+})^{\vee}) \quad \forall \mathfrak{e}.$$

This happens because, by the definition of twisted curves 2.4.1, the local picture of \mathbb{C} at \mathfrak{e} is $\{zw = 0\}$ with $\boldsymbol{\mu}_{l(\mathfrak{e})}$ acting as $(z, w) \mapsto (\xi_{l(\mathfrak{e})}z, \xi_{l(\mathfrak{e})}^{-1}w)$. \square

3.2.22. *Proof of Theorem 3.2.2.* We prove the claim by chasing in the following diagram derived from Theorem 3.2.3 and Corollary 3.2.16. First, we list our notation:

1. $P_{\mathfrak{e}}$ denotes $\text{Pic}(\mathbb{B}\text{Aut}(\mathfrak{e}))$, and P denotes $\prod_{\mathfrak{e}} P_{\mathfrak{e}}$;
2. for any group H , H_r denotes the r -torsion subgroup;
3. ∂ denotes the differential of $\mathcal{C}_{\bullet}(\Lambda, \mathbb{Z}/r\mathbb{Z})$ for Λ the dual graph of \mathbb{C} with an orientation;
4. \mathfrak{j} denotes the embedding of the singular locus in \mathbb{C} ;
5. π denotes the morphism from \mathbb{C} to $|\mathbb{C}|$.

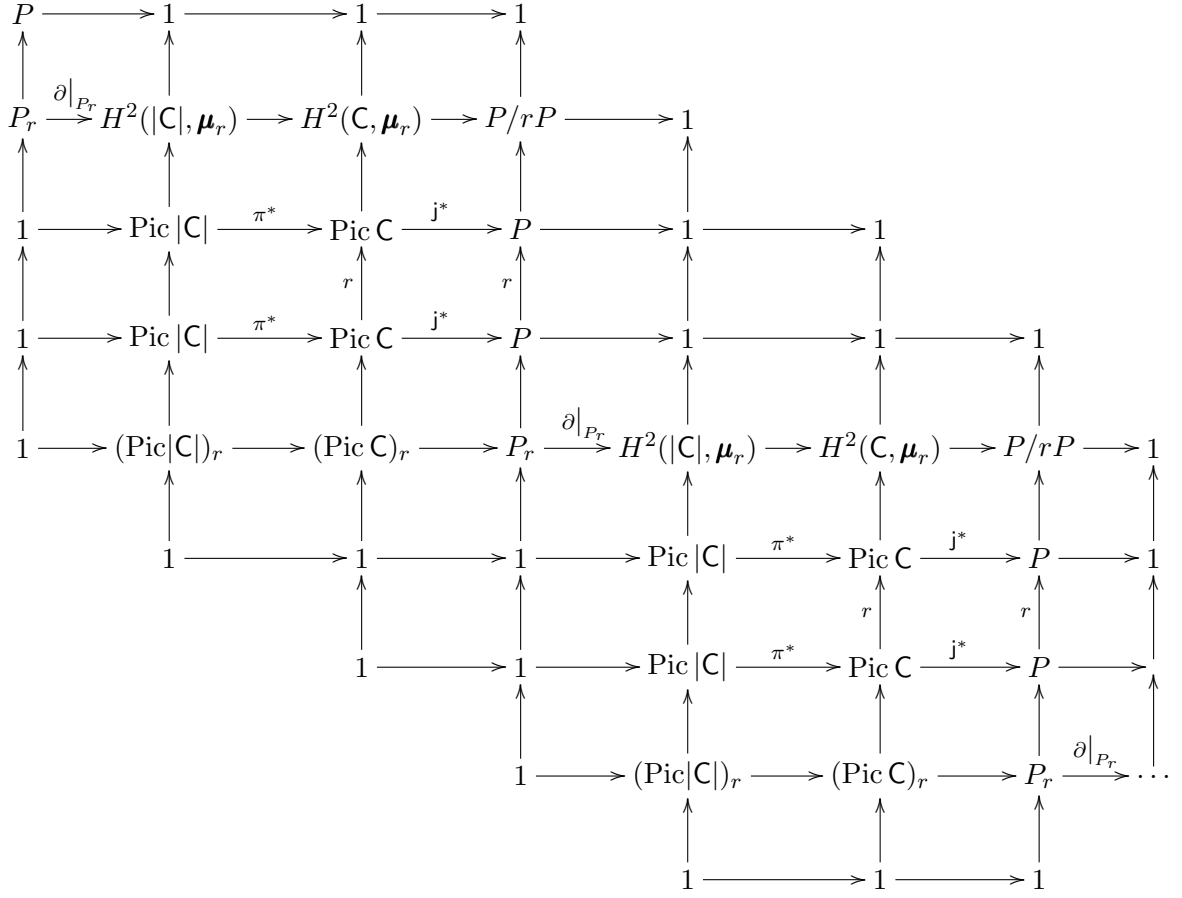

Figure 2: the diagram is commutative and all horizontal and vertical sequences are exact.

We prove Theorem 3.2.2 in two steps: we first focus on roots of \mathcal{O} ; then, we consider the roots of F .

Step 1. The special case: r th roots of \mathcal{O} . We show that there are exactly r^{2g} roots of \mathcal{O} if and only if $l(\mathbf{e})$ is a multiple of r for any nonseparating node \mathbf{e} . This is indeed the claim of the theorem in the case $F = \mathcal{O}$, because $\eta(\mathbf{e}) = r$ on separating nodes, and equals $\text{hcf}\{r, l(\mathbf{e})\}$ on nonseparating nodes. By Theorem 3.2.3 (see Figure 2), the number of elements of $\text{Pic}(\mathcal{C})_r$ equals the product of $\#((\text{Pic}|C|)_r) = r^{2g-1+\#(V)-\#(E)}$ by the size of the kernel of

$$\partial: P_r \rightarrow H^2(|C|, \boldsymbol{\mu}_r). \quad (3.2.23)$$

Therefore, it is enough to show the following claim

$$\#(\ker \partial) = r^{1-\#(V)+\#(E)} \Leftrightarrow l(\mathbf{e}) \in r\mathbb{Z} \quad \forall \mathbf{e} \text{ nonseparating}. \quad (3.2.24)$$

Recall that the first Betti number of the dual graph Λ of C is $b_1(\Lambda) = 1 - \#(V) + \#(E)$. Consider the subgraph $\Lambda(\mathbf{e})$ of Λ of $|C|$, whose vertices and edges are V and $E \setminus \{\mathbf{e}\}$, denote by $\widehat{\partial}_{\mathbf{e}}$ the

restriction of the chain differential of $\Lambda(\mathbf{e})$ to $P_r(\mathbf{e}) = \prod_{E \setminus \{\mathbf{e}\}} (P_{\mathbf{e}})_r$. For any nonseparating $\mathbf{e} \in E$, we have

$$\#(\ker \partial) = \#(\ker \widehat{\partial}_{\mathbf{e}}) \cdot \text{hcf}\{r, l(\mathbf{e})\}. \quad (3.2.25)$$

The claim (3.2.24) follows. Indeed, assume $\#(\ker \partial) = r^{1-\#(V)+\#(E)}$. Now, we have $\#(\ker \widehat{\partial}_{\mathbf{e}}) \leq r^{b_1(\Lambda(\mathbf{e}))}$ and $b_1(\Lambda(\mathbf{e})) = b_1(\Lambda) - 1$ if \mathbf{e} is nonseparating. Hence, $r = \text{hcf}\{r, l(\mathbf{e})\}$. Conversely, assume $l(\mathbf{e}) \in r\mathbb{Z}$ for all nonseparating \mathbf{e} . The claim holds when there are $n - 1$ nonseparating edges, then (3.2.25) implies $\#(\ker \partial) = r^{b_1(\Lambda(\mathbf{e}))+1} = r^{1-\#(V)+\#(E)}$.

Step 2. The general case: r th roots of F . We first assume $\eta(\mathbf{e}) = r$ for all nodes, and we show that it implies that F has one r th root (by Step 1, this also implies that the number of roots is r^{2g}).

By the diagram in Figure 2, this amounts to a combinatorial criterion on the differential of $\mathcal{C}^\bullet(\Lambda, \mathbb{Z}/r\mathbb{Z})$ (recall that an orientation for Λ is chosen). The point is that for any line bundle A on the curve $|C|$ the pullback π^*A has an r th root in $\text{Pic}(C)$ if and only if $\deg(A)$ is in the image of ∂ in Figure 2.

In order to state the criterion we attach a partition of $E \setminus \{\mathbf{e}\}$ and V to each separating node \mathbf{e} joining v_+ and v_- :

$$E \setminus \{\mathbf{e}\} = E^+ \sqcup E^- \quad V = V^+ \sqcup V^-,$$

where the set E^+ (the set V^+) contains the edges (the vertices) that can be connected to v_+ without passing through \mathbf{e} . Then, regard P_r as the product $\prod_{\mathbf{e} \in E} (P_{\mathbf{e}})_r$ and write $P^\pm(\mathbf{e}) = \prod_{\mathbf{e} \in E^\pm} (P_{\mathbf{e}})_r$, write $\partial_{\mathbf{e}}^\pm$ for the corresponding chain differentials, and denote by $\varepsilon_{\mathbf{e}}^\pm$ the composition of $V^\pm \hookrightarrow V$ with the augmentation homomorphism $\varepsilon: V \rightarrow \mathbb{Z}/r\mathbb{Z}$ (over $\ker \varepsilon$, we obviously have $\varepsilon_{\mathbf{e}}^+ = -\varepsilon_{\mathbf{e}}^-$).

3.2.26 Lemma. *Assume that r divides $l(\mathbf{e})$ if \mathbf{e} is nonseparating. Consider an element $\vec{t} \in \ker \varepsilon \in (\mathbb{Z}/r\mathbb{Z})^V$; the following conditions are equivalent.*

1. \vec{t} is in the image of $P_r \subseteq (\mathbb{Z}/r\mathbb{Z})^E$ via ∂ .
2. For any separating edge \mathbf{e} , the value of $\varepsilon_{\mathbf{e}}^+(\vec{t}) \in \mathbb{Z}/r\mathbb{Z}$ belongs to $P_{\mathbf{e}}$ (or, equivalently, the value of $\varepsilon_{\mathbf{e}}^-(\vec{t}) = -\varepsilon_{\mathbf{e}}^+(\vec{t})$ belongs to $P_{\mathbf{e}}$).

Proof. Note that the claim is trivial if all edges are nonseparating. Indeed, (2) is true, whereas (1) is true, because if $\varepsilon(\vec{t})$ vanishes, then \vec{t} is exact in \mathcal{C}^\bullet and lies in $\partial(P_r)$ by $l(\mathbf{e}) \in r\mathbb{Z}$.

Then, choose a separating edge \mathbf{e} joining v^+ to v^- . Note that, the homomorphism ∂ can be written as

$$\begin{array}{ccc} P^+(\mathbf{e}) \times (P_{\mathbf{e}})_r \times P^+(\mathbf{e}) & \rightarrow & (\mathbb{Z}/r\mathbb{Z})^{V^+} \quad \times \quad (\mathbb{Z}/r\mathbb{Z})^{V^-} \\ (a, x, b) & \mapsto & (\partial_{\mathbf{e}}^+(a) + i_+(x), \quad \partial_{\mathbf{e}}^-(b) - i_-(x)), \end{array}$$

where i^+ and i^- are the injections of $(P_{\mathbf{e}})_r$ in $(\mathbb{Z}/r\mathbb{Z})^{V^+}$ and $(\mathbb{Z}/r\mathbb{Z})^{V^-}$ induced by $v^+ \in V^+$ and $v^- \in V^-$.

We assume $\vec{t} \in \partial(P_r)$, and we prove (2). Indeed, there exist $a \in P^+(\mathbf{e})$ and $x \in (P_{\mathbf{e}})_r$ satisfying $\varepsilon_{\mathbf{e}}^+(\vec{t}) = \varepsilon_{\mathbf{e}}^+(\partial_{\mathbf{e}}^+(a) + i_+(x))$. Therefore, we have $\varepsilon_{\mathbf{e}}^+(\vec{t}) = \varepsilon_{\mathbf{e}}^+(i_+(x)) = x \in P_{\mathbf{e}}$.

Conversely, choose a separating edge \mathbf{e} , and set $x_{\mathbf{e}} = \varepsilon_{\mathbf{e}}^+(\vec{t}) \in (P_{\mathbf{e}})_r$. We construct $\vec{h} \in P_r$ such that $\partial(\vec{h}) = \vec{t}$, by means of the presentation of ∂ given in the diagram above. Using the

partition $V = V^+ \sqcup V^-$, write \vec{t} as $(\vec{t}_e^+, \vec{t}_e^-)$. Now, giving \vec{h} is equivalent to finding two elements mapping via ∂_e^+ and ∂_e^- to $\vec{q}_e^+ = \vec{t}_e^+ - i_e^+(x_e)$ and $\vec{q}_e^- = \vec{t}_e^- + i_e^+(x_e)$. By induction on the number of separating edges, the lemma holds on the subgraphs with edges E^+ (or E^-) and vertices V^+ (or V^-). Therefore, in order to lift $\vec{q} = \vec{q}_e^+$ and \vec{q}_e^- to $P^+(\mathbf{e})$ and $P^-(\mathbf{e})$, we only need to show that \vec{q} satisfies (2). This is immediate, since, by construction, for any separating edge f we have either $\varepsilon_f^+(\vec{q}) = \varepsilon_f^+(\vec{t})$ or $\varepsilon_f^-(\vec{q}) = \varepsilon_f^-(\vec{t})$. \square

Assuming $\eta(\mathbf{e}) = r$ we construct an r th root of F . Using the orientation of the dual graph Λ chosen above, we have a canonical way to associate to a node \mathbf{e} a point \mathbf{p}_+ over \mathbf{e} lying in the normalization of C at \mathbf{e} . We set $m(\mathbf{e}) = \text{mult}_{\mathbf{p}_+}(F)$. In the same way, for any separating node \mathbf{e} , the orientation allows us to associate to \mathbf{e} a component $C_+(\mathbf{e})$ of the partial normalization of C at \mathbf{e} . Then, we set $d(\mathbf{e}) = \text{deg}_{C_+(\mathbf{e})}(F)$. Since r divides $\eta(\mathbf{e})$ there exists a function $k(\mathbf{e}) \in \mathbb{Z}$ satisfying

$$d(\mathbf{e})l(\mathbf{e}) = k(\mathbf{e})r \quad \text{for separating nodes and} \quad (3.2.27)$$

$$m(\mathbf{e}) = k(\mathbf{e})r \quad \text{for nonseparating nodes.} \quad (3.2.28)$$

The orientation of the dual graph Λ also induces a canonical generator $T_{\mathbf{p}_+}$ for each group $\text{Pic}(\mathbf{B} \text{Aut}(\mathbf{e}))$. We consider

$$\prod_{\mathbf{e}} T_{\mathbf{p}_+}^{\otimes k(\mathbf{e})} \in \prod_{\mathbf{e}} P_{\mathbf{e}}.$$

Let M be a line bundle on C such that $j^*M = \prod_{\mathbf{e}} T_{\mathbf{p}_+}^{\otimes k(\mathbf{e})}$. By the equations (3.2.27) and (3.2.28) and Proposition 2.2.10, we have $j^*(M^{\otimes r}) = j^*F$. Therefore, there exists a line bundle $A \in \text{Pic}|C|$ satisfying $\pi^*A = (M^{\otimes r})^\vee \otimes F$.

In fact, π^*A has an r th root, because it lies in the kernel of $\text{Pic}(C) \rightarrow H^2(C, \boldsymbol{\mu}_r)$. To see this, using the diagram of Figure 2, it is enough to show that the homomorphism $\text{Pic}|C| \rightarrow H^2(|C|, \boldsymbol{\mu}_r)$ sends A into $\partial(P_r)$. We apply Lemma 3.2.26 to the multidegree of A mod r ; clearly, condition (2) of the lemma holds if the following numerical condition is satisfied for each separating node: the total degree of π^*A on the connected component $\tilde{C} = C_+(\mathbf{e})$ is a multiple of r . Indeed, r divides

$$\text{deg}(\pi^*A|_{\tilde{C}}) = \text{deg}((M^{\otimes r})^\vee \otimes F)|_{\tilde{C}} = -r \text{deg}(M|_{\tilde{C}}) + d(\mathbf{e}) = r(-\text{deg}(M|_{\tilde{C}}) + d(\mathbf{e})/r),$$

because $\text{deg}(M|_{\tilde{C}}) - k(\mathbf{e})/l(\mathbf{e})$ is an integer by Proposition 2.2.10 and $k(\mathbf{e})/l(\mathbf{e}) = d(\mathbf{e})/r$ by (3.2.27). This proves the claim, because by tensoring a root of π^*A by M we get a root of F .

Conversely, if F has r^{2g} r th roots, we show $l(\mathbf{e}), m(\mathbf{e}) \in r\mathbb{Z}$ for any nonseparating node \mathbf{e} and $l(\mathbf{e})d(\mathbf{e}) \in r\mathbb{Z}$ for any separating node \mathbf{e} . First, for any nonseparating node \mathbf{e} , Step 1 implies $l(\mathbf{e}) \in r\mathbb{Z}$, and, since F has an r th root, j^*F also has an r th root, and we have $m(\mathbf{e}) \in r\mathbb{Z}$. Second, we show $l(\mathbf{e})d(\mathbf{e}) \in r\mathbb{Z}$ for a separating node \mathbf{e} . Since j^*F has an r th root and j^* is surjective, we can choose a line bundle M on C such that $j^*M^{\otimes r} = j^*F$. There exists $A \in \text{Pic}|C|$ such that $\pi^*A = (M^{\otimes r})^\vee \otimes F$. Since F has an r th root, π^*A has an r th root; therefore, the homomorphism $\text{Pic}|C| \rightarrow H^2(|C|, \boldsymbol{\mu}_r)$ sends A into the image of $\partial: P_r \rightarrow H^2(|C|, \boldsymbol{\mu}_r)$. Note that, by Lemma 3.2.26, the degree of π^*A on $C_+(\mathbf{e})$ has order $l(\mathbf{e})$ modulo r ; hence, we have

$$l(\mathbf{e}) \text{deg}(\pi^*A|_{C_+(\mathbf{e})}) \in r\mathbb{Z},$$

which implies $l(\mathbf{e})d(\mathbf{e}) \in r\mathbb{Z}$, because

$$l(\mathbf{e}) \deg(\pi^* A|_{C_+(\mathbf{e})}) = l(\mathbf{e}) \deg(j^*(M^{\otimes r})^\vee \otimes F)|_{C_1} = -rl(\mathbf{e}) \deg(M|_{C_1}) + l(\mathbf{e})d(\mathbf{e}).$$

□

4 The notion of stability for twisted curves and for r th roots

4.1 Twisted curves and the notion of \vec{l} -stability

By Olsson's Theorem 2.4.6, the category of twisted curves of genus $g \geq 2$ forms a Deligne–Mumford stack. As the following example shows, the stack $\tilde{\mathcal{M}}_g$ is not separated.

4.1.1 Example. A twisted curve C over a discrete valuation ring R with smooth generic fibre C_K is isomorphic to its coarse space over K and may differ from it on the special fibre; in this case the coarse space $|C|$ and C are two nonisomorphic twisted curves extending C_K on S . Therefore, the valuative criterion of separateness fails.

Inside $\tilde{\mathcal{M}}_g$, we identify all proper substacks containing \mathcal{M}_g . We need to recall the following standard notion of type of a node.

4.1.2 Notation (type of a node). Given a twisted curve of genus $g \geq 2$ over k and a node $e \in C$ we set the following convention:

$$e \in C \text{ is } \begin{cases} \text{of type } 0 & \text{if the normalization of } C \text{ at } e \text{ is connected} \\ & \text{(i.e. } e \text{ is nonseparating);} \\ \text{of type } i \text{ with} & \text{if the normalization of } C \text{ at } e \text{ is } C_1 \sqcup C_2 \\ 1 \leq i \leq \lfloor g/2 \rfloor & \text{and } \{g(C_1), g(C_2)\} = \{i, g-i\}. \end{cases}$$

4.1.3 Definition. Let $\vec{l} = (l_0, l_1, \dots, l_{\lfloor g/2 \rfloor})$ be a multiindex of positive integers l_i , prime to $\text{char}(k)$. A twisted curve $C \rightarrow X$ is \vec{l} -stable, if the coarse space is stable and if the stabilizer at a node of type i has order l_i .

4.1.4 Theorem. *Let us denote by $\mathcal{M}_g(\vec{l})$ the category of \vec{l} -stable curves. It is contained in $\tilde{\mathcal{M}}_g$ and it contains \mathcal{M}_g :*

$$\mathcal{M}_g \hookrightarrow \mathcal{M}_g(\vec{l}) \hookrightarrow \tilde{\mathcal{M}}_g.$$

- I. *The stack $\mathcal{M}_g(\vec{l})$ is tame, proper (separated), smooth, irreducible and of Deligne–Mumford type. The morphism $\mathcal{M}_g(\vec{l}) \rightarrow \overline{\mathcal{M}}_g$ is finite, flat, and is an isomorphism on the open dense substack \mathcal{M}_g .*
- II. *Any proper substack X of $\tilde{\mathcal{M}}_g$ fitting in $\mathcal{M}_g \hookrightarrow X \hookrightarrow \tilde{\mathcal{M}}_g$ is isomorphic to $\mathcal{M}_g(\vec{l})$ for a suitable multiindex \vec{l} .*

Proof. There is a natural surjective morphism

$$\tilde{\mathcal{M}}_g \rightarrow \overline{\mathcal{M}}_g,$$

which is the functor sending a twisted curve $C \rightarrow X$ to the coarse space $|C| \rightarrow X$. Note that M_g is dense in \widetilde{M}_g : by Theorem 2.4.6 any twisted curve $C \rightarrow \text{Spec } k$ can be realized as the special fibre of a twisted curve C' over a discrete valuation ring in such a way that the generic fibre is smooth.

Point (I) follows from [Ol, Thm. 1.9] and, in particular, from the description of versal deformation spaces (2.4.7). The morphism $M_g(\vec{l}) \rightarrow \overline{M}_g$ is locally represented by the flat, finite, tame morphism of Deligne–Mumford type

$$[(\text{Spec } \widetilde{I})/\mu_{h_1} \times \cdots \times \mu_{h_m}] \rightarrow \text{Spec } I \quad (4.1.5)$$

where I is the versal deformation space of a point of \overline{M}_g , m is the number of nodes of the curve represented by such point, $\widetilde{I} = I[z_1, \dots, z_m]/(z_1^{h_1} - t_1, \dots, z_m^{h_m} - t_m)$ and $\mu_{h_1} \times \cdots \times \mu_{h_m}$ acts as $(\xi_{h_1}, \dots, \xi_{h_m})z_i = \xi_{h_j}z_j$ (note that the index h_j depends on the type of the j th node and $h_j = l_i$ if the j th node is of type i). This means that $M_g(\vec{l})$ is smooth, which is also shown in [ACV03, §3] and [AJ03, §3]. The fact that $M_g(\vec{l})$ is irreducible is a consequence of the fact that M_g is dense on $M_g(\vec{l})$.

We show (II). Let X be a proper stack, which contains M_g and is contained in \widetilde{M}_g . By restriction of $\widetilde{M}_g \rightarrow \overline{M}_g$ to X , we obtain a morphism of proper stacks $f: X \rightarrow \overline{M}_g$. Note that M_g is dense in X and in \overline{M}_g . The valuative criterion of properness for X and \overline{M}_g implies that for any geometric point $y: \text{Spec } k \rightarrow \overline{M}_g$ there exists a point $x: \text{Spec } k \rightarrow X$ lifting y . In fact x is unique. To see this, consider a versal deformation $\text{Spec } I \rightarrow \overline{M}_g$ at y . The base change of $X \rightarrow \overline{M}_g$ via $\text{Spec } I \rightarrow \overline{M}_g$ is a restriction of (4.1.5). The point y is in the locus $z_1 = z_2 = \cdots = z_m = 0$ and admits only one lifting.

Now, we define positive indexes $\vec{l} = (l_0, l_1, \dots, l_{[g/2]})$ such that $X \cong M_g(\vec{l})$. Denote by $u: U(\overline{M}_g) \rightarrow \overline{M}_g$ the universal stable curve. Let $p: \text{Spec } k \rightarrow U(\overline{M}_g)$ be a node of type i . Let $q: \text{Spec } k \rightarrow X$ be the unique morphism which lifts $u \circ p$. The object determined by q is a twisted curve C , whose coarse space $|C|$ is represented by the point $u \circ p$. We define l_i as the order of the stabilizer of C on the node p . The index l_i is locally constant on the (connected) substack of $U(\overline{M}_g)$ of nodes of type i . Therefore, l_i only depends on i . This implies that the objects of X are \vec{l} -stable curves. Finally, the properness of X implies that any point $\text{Spec } k \rightarrow M_g(\vec{l})$ lifts to X . Since $M_g(\vec{l})$ is regular, this suffices to show that X is isomorphic to $M_g(\vec{l})$. \square

In fact, the stack $M_g(\vec{l})$ admits an alternative description.

The first part of Olsson's proof of Theorem 2.4.6 in [Ol] consists of constructing a functor from the category of twisted curves to the category of simple logarithmic extensions of the logarithmic structure \mathcal{M}_Δ on \overline{M}_g canonically associated to the boundary locus $\Delta = \overline{M}_g \setminus M_g$. Indeed, the boundary locus is a normal crossings divisor $\Delta = \sum_i \Delta_i$ where Δ_i is the full subcategory of stable curves $C \rightarrow X$ where the fibre on every $x \in X$ is a curve containing at least a node of type i (recall that a logarithmic structure is canonically associated to any normal crossings divisor [Ka89, 1.5]). The second part of Olsson's proof shows that simple extensions of logarithmic structures form an algebraic stack.

We point out that, by [Ol, Lem. 5.3], Olsson's functor can be regarded as an equivalence between the *subcategory* $M_g(\vec{l})$ of $\vec{l} = (l_0, l_1, \dots, l_{[g/2]})$ -stable curves and the *subcategory* of simple extensions $\mathcal{M}_\Delta \rightarrow \mathcal{N}$ of locally free logarithmic structures inducing, at each geometric

point $x: \text{Spec } k \rightarrow X$, the commutative diagram

$$\begin{array}{ccc} \mathbb{N}^{\oplus k} & \xrightarrow{\oplus_{i=1}^k \times a_i} & \mathbb{N}^{\oplus k} \\ \downarrow & & \downarrow \\ \overline{\mathcal{M}}_{\Delta, x} & \longrightarrow & \overline{\mathcal{N}}_x \end{array}$$

where $\{1, \dots, k\}$ is the set of irreducible components of the local picture of Δ at x , and $a_i = l_j$ if $i \in \{1, \dots, k\}$ corresponds to the component Δ_j in Δ (following Olsson we adopt the notation $\overline{\mathcal{M}}_{\Delta} = \mathcal{M}_{\Delta}/\mathcal{O}^{\times}$, $\overline{\mathcal{N}} = \mathcal{N}/\mathcal{O}^{\times}$ and we refer to [MO05, Lem 4.2] for the proof of the canonical decomposition of $\overline{\mathcal{M}}_{\Delta, x} \cong \mathbb{N}^{\oplus k}$).

Now, we notice that this subcategory of logarithmic extensions is precisely the category used in Matsuki and Olsson's Generalization 2.2.5. In this way, we get the following statement.

4.1.6 Theorem. *For any multiindex $(l_0, l_1, \dots, l_{\lfloor g/2 \rfloor})$, we have the following isomorphism*

$$\begin{array}{ccc} \mathbb{M}_g(\vec{l}) & \cong & \overline{\mathbb{M}}_g(\sum_i \Delta_i/l_i) \\ & \searrow & \swarrow \\ & \overline{\mathbb{M}}_g & \end{array}$$

where $\mathbb{M}_g(\vec{l})$ is the stack of \vec{l} -stable curves and $\overline{\mathbb{M}}_g(\sum_i \Delta_i/l_i)$ is the stack of simple extensions of the logarithmic structure associated to $\sum_i \Delta_i$ with indexes l_i in the sense of [MO05, (4.2.2)]. \square

4.2 The moduli stack of r th roots on \vec{l} -stable curves

Let LB_g be the category formed by pairs $(C \rightarrow X, M)$, where $C \rightarrow X$ is a smooth curve and M is a line bundle on C . The stack LB_g is the category fibred over \mathbb{M}_g whose fibre over a smooth curve $f: C \rightarrow X$ is the stack LB_f . Let \mathbb{F} be a line bundle on the universal curve of \mathbb{M}_g , whose relative degree is a multiple of r . Let $\mathbb{M}_g^{\mathbb{F}, r}$ be the fibred category whose fibre over $f: C \rightarrow X$ is $\mathbb{F}^{1/r}$. By Proposition 3.1.3, $\mathbb{M}_g^{\mathbb{F}, r}$ is a Deligne–Mumford stack, étale over \mathbb{M}_g .

It is well known that \mathbb{F} is a power $\omega^{\otimes k}$ of the relative dualizing sheaf modulo pullbacks from \mathbb{M}_g (Enriques and Franchetta's conjecture, [Ha83] [Me87] [AC87]). In view of a compactification of $\mathbb{M}_g^{\mathbb{F}, r}$, we focus on the case

$$\mathbb{F} = \omega^{\otimes k}$$

and we assume

$$(2g - 2)k \in r\mathbb{Z}.$$

We extend LB_g to $\widetilde{\mathbb{M}}_g$: we consider the category $\widetilde{\text{LB}}_g$ formed by pairs $(C \rightarrow X, M)$ where $C \rightarrow X$ is a twisted curve and M is a line bundle on C , Remark 3.1.1. We get the stack

$$\widetilde{\text{LB}}_g \rightarrow \widetilde{\mathbb{M}}_g. \tag{4.2.1}$$

By abuse of notation, we denote by \mathbb{F} the power of the relative dualizing sheaf $\omega^{\otimes k}$ on the universal curve over $\widetilde{\mathbb{M}}_g$. Let $\widetilde{\mathbb{M}}_g^{\mathbb{F}, r}$ be the fibred category over $\widetilde{\mathbb{M}}_g$ whose fibre over $f: C \rightarrow X$ is

the stack of $F^{1/r}$ of r th roots of F on C . In this way, the objects of $\widetilde{M}_g^{F,r}$ are triples $(C \rightarrow X, L, j)$, where C is a twisted curve, L is a line bundle on C and j is an isomorphism $j: L^{\otimes r} \rightarrow F_C$. Morphisms from $(C \rightarrow X, L, j)$ to $(C' \rightarrow X', L', j')$ are pairs (m, a) where $m: C \rightarrow C'$ is a morphism of twisted curves and $a: L \rightarrow m^*L'$ is an isomorphism of line bundles, with $a^{\otimes r}$ commuting with j and j' .

By Proposition 3.1.3, $\widetilde{M}_g^{F,r}$ is a Deligne–Mumford stack étale over \widetilde{M}_g

$$\widetilde{M}_g^{F,r} \rightarrow \widetilde{M}_g, \quad (4.2.2)$$

which can be regarded as the projection on the second factor of the fibred product $(\widetilde{LB}_g)_{k_r \times_F} \widetilde{M}_g$ fitting in

$$\begin{array}{ccc} \widetilde{M}_g^{F,r} & \longrightarrow & \widetilde{LB}_g \\ \downarrow & \square & \downarrow k_r \\ \widetilde{M}_g & \xrightarrow{F} & \widetilde{LB}_g \end{array}$$

where k_r is induced by the r th power in \mathbb{G}_m and $F = \omega^{\otimes k}$ is regarded as a section of (4.2.1).

We consider the étale morphism $\widetilde{M}_g^{F,r} \rightarrow \widetilde{M}_g$. Its restriction to the stack $M_g^{F,r}$ of r th roots of F on smooth curves $C \rightarrow X$ forms a finite stack on M_g equipped with a torsor structure under the group stack $M_g^{\mathcal{O},r}$. On the other hand \widetilde{M}_g is not separated and so is $\widetilde{M}_g^{F,r}$. By Theorem 4.1.4, we can consider the base changes to all compactifications of M_g in \widetilde{M}_g : we get $M_g^{F,r}(\vec{l}) \rightarrow \widetilde{M}_g(\vec{l})$ via $M_g(\vec{l}) \hookrightarrow \widetilde{M}_g$:

$$\begin{array}{ccccc} M_g^{F,r} & \longrightarrow & M_g^{F,r}(\vec{l}) & \longrightarrow & \widetilde{M}_g^{F,r} \\ \downarrow & \square & \downarrow & \square & \downarrow \\ M_g & \longrightarrow & M_g(\vec{l}) & \longrightarrow & \widetilde{M}_g \end{array}$$

We now characterize the compactifications for which the morphism $M_g^{F,r}(\vec{l}) \rightarrow \widetilde{M}_g(\vec{l})$ is proper.

4.2.3 Theorem. *For any $F = \omega^{\otimes k}$, the category $M_g^{F,r}(\vec{l})$ is a smooth Deligne–Mumford algebraic stack, étale on $M_g(\vec{l})$.*

I. *For $F = \mathcal{O}$, the stack $M_g^{\mathcal{O},r}(\vec{l})$ is a finite group stack if and only if we have*

$$l_0 \in r\mathbb{Z}.$$

II. *For $F = \omega$ and $2g - 2 \in r\mathbb{Z}$, the stack $M_g^{\omega,r}(\vec{l})$ is a finite group stack and $M_g^{\omega,r}(\vec{l})$ is a finite torsor under $M_g^{\mathcal{O},r}(\vec{l})$ if and only if we have*

$$(2i - 1)l_i \in r\mathbb{Z} \text{ for all } i.$$

In this way, we obtain several compactifications of the stack $M_g^{\omega,r}$ of smooth r -spin curves: for each \vec{l} satisfying $l_i(2i - 1) \in r\mathbb{Z}$,

$$M_g^{\omega,r}(\vec{l}) \rightarrow M_g(\vec{l})$$

is the finite torsor of r -spin \vec{l} -stable curves.

III. More generally, for $F = \omega^{\otimes k}$ and $(2g - 2)k \in r\mathbb{Z}$, the stack $M_g^{\circlearrowleft, r}(\vec{l})$ is a finite group stack and $M_g^{F, r}(\vec{l})$ is a finite torsor under $M_g^{\circlearrowleft, r}(\vec{l})$ if and only if we have

$$l_0 \in r\mathbb{Z} \quad \text{and} \quad (2i - 1)kl_i \in r\mathbb{Z}, \quad \text{for } i > 0.$$

Proof. It is enough to show (III). We calculate the invariant η of Theorem 3.2.2 for $F = \omega^{\otimes k}$. Let e be a node of a twisted curve. We have $\eta(e) = \text{hcf}\{r, \#(\text{Aut}(e))\}$ if e is nonseparating and $\eta(e) = \text{hcf}\{r, \#(\text{Aut}(e))k(2i - 1)\}$ if e is separating and of type i . Then, Theorem 3.2.2 implies the claim. \square

4.2.4 Proposition. *The category $M_g^{\circlearrowleft, r}(\vec{l})$ is equivalent to the category of μ_r -torsors on \vec{l} -stable curves. In this way, as soon as r divides l_0 , the stack $M_g^{\circlearrowleft, r}(\vec{l})$ is a compactification of the stack of μ_r -torsors on smooth curves.*

Proof. There is a natural functor from μ_r -torsors to r -torsion line bundles. Given a torsor T on C with an action of μ_r , consider $P = T \times_C \mathbb{A}^1$ over C . Note that μ_r acts on both factors and the diagonal action on the fibre product is free. The quotient P/μ_r yields an r -torsion line bundle on C . The functor is essentially surjective and fully faithful. \square

4.2.5 Remark. For each object of $M_g^{F, r}(\vec{l})$ there is an injection of μ_r in the automorphism group (the r th roots of unity act by multiplication along the fibres of the line bundle). The rigidification of $M_g^{F, r}(\vec{l})$ along the group scheme μ_r yields a representable cover $H(F)^{\mu_r}$ of $M_g(\vec{l})$, see Proposition 3.1.5. In this way, the morphism $M_g^{F, r}(\vec{l}) \rightarrow M_g(\vec{l})$ factors as

$$M_g^{F, r}(\vec{l}) \rightarrow H(F)^{\mu_r} \rightarrow M_g(\vec{l}),$$

where $H(F)^{\mu_r} \rightarrow M_g(\vec{l})$ is a representable cover of degree r^{2g} and $M_g^{F, r}(\vec{l}) \rightarrow H(F)^{\mu_r}$ is an étale μ_r -gerbe. By Proposition 3.1.5 and Proposition 3.1.6, as soon as \vec{l} satisfies $l_0 \in r\mathbb{Z}$ and $(2i - 1)kl_i \in r\mathbb{Z}$ for $i > 0$ the base change of $H(\mathcal{O})^{\mu_r} \rightarrow M_g(\vec{l})$ and of $H(F)^{\mu_r} \rightarrow M_g(\vec{l})$ with respect to a morphism from a scheme X to $M_g(\vec{l})$ yields a finite group X -scheme G_X and a finite torsor T_X under G_X .

4.2.6 Remark (λ -stable curves). Note that Theorem 4.2.3 is automatically satisfied if $l_i = \lambda$ for all i and λ is a multiple of r . In this case, we write “ λ -stable” instead \vec{l} -stable.

4.2.7 Remark (n -pointed curves). Olsson’s results [Ol, Thm. 1.9] are formulated in terms of n -pointed curves; therefore, the category $\tilde{M}_{g, n}$ of twisted curves, with n ordered distinct markings $\sigma_1, \dots, \sigma_n$ in the smooth locus, is a Deligne–Mumford stack. We point out that our method produces proper stacks of r th roots of any line bundle $F = \omega^{\otimes k}(\sum_i -h_i[\sigma_i])$ on the universal twisted curve over $\tilde{M}_{g, n}$ for all integers k, h_1, \dots, h_n satisfying $(2g - 2)k - \sum_i h_i \in r\mathbb{Z}$. (The case $k = 1$ is relevant to Witten’s conjecture [Wi93]). This happens by Corollary 3.0.8 and the fact that $F = \omega^{\otimes k}$ is a pullback from the universal (scheme-theoretic) stable n -pointed curve over $\tilde{M}_{g, n}$, Proposition 2.5.1. In general, Corollary 3.0.8 yields the following statement.

4.2.8 Corollary. *Let F be a line bundle on the universal twisted n -pointed curve isomorphic to a pullback from the universal stable n -pointed curve. Let $\tilde{M}_{g, n}^{F, r}$ be the fibred category on $\tilde{M}_{g, n}$ of r th roots of F on twisted curves. It is a stack, étale on $\tilde{M}_{g, n}$. It is nonempty, as long as we assume that the relative degree of F is a multiple of r .*

For any $\lambda \in \mathbb{Z}$, the stack of λ -stable n -pointed curves $M_{g,n}(\lambda)$ is smooth, irreducible, and proper. If r divides λ , the stack $M_{g,n}^{\mathcal{O},r}(\lambda)$ of r -torsion line bundles on λ -stable n -pointed curves is a finite group stack and the stack $M_{g,n}^{\mathbb{F},r}(\lambda)$ of r th roots of \mathbb{F} on λ -stable curves is a finite torsor under the group stack $M_{g,n}^{\mathcal{O},r}(\lambda)$.

In this way, we obtain several compactifications of the stack $M_{g,n}^{\omega,r}$ of smooth r -spin n -pointed curves: for each $\lambda \in r\mathbb{Z}$,

$$M_{g,n}^{\omega,r}(\lambda) \rightarrow M_{g,n}(\lambda)$$

is the finite torsor of r -spin n -pointed λ -stable curves. \square

4.2.9 Remark. Let r_1 and r_2 be positive and coprime integers. In [JKV00, §4, Rem. 4.11], it is noted that the functor $L \mapsto (L^{\otimes r_2}, L^{\otimes r_1})$ is an isomorphism $M_g^{\mathbb{F},r_1 r_2} \cong M_g^{\mathbb{F},r_1} \times_{M_g} M_g^{\mathbb{F},r_2}$, that does not extend to the compactifications given in the existing literature. With our formalism the isomorphism extends immediately (we omit markings for simplicity).

4.2.10 Proposition (roots of two coprime orders). *Let r_1 and r_2 be positive and coprime integers. Set $\lambda = r_1 r_2$. The functor $L \mapsto (L^{\otimes r_2}, L^{\otimes r_1})$ is an isomorphism of stacks*

$$M_g^{\mathbb{F},r_1 r_2}(\lambda) \cong M_g^{\mathbb{F},r_1}(\lambda) \times_{M_g(\lambda)} M_g^{\mathbb{F},r_2}(\lambda).$$

Proof. The inverse functor is $(L_1, L_2) \mapsto L_1^{\otimes h_2} \otimes L_2^{\otimes h_1}$ for h_1 and h_2 satisfying $h_1 r_1 + h_2 r_2 = 1$. Indeed, we have $(L_1^{\otimes h_2} \otimes L_2^{\otimes h_1})^{\otimes r_1 r_2} = L_1^{\otimes r_1 r_2 h_2} \otimes L_2^{\otimes r_1 r_2 h_1} \cong \mathbb{F}^{\otimes h_1 r_1 + h_2 r_2} = \mathbb{F}$. \square

4.2.11 Example ($g = 1$ and $n = 1$). Consider the twisted curve $C = [E/\mu_2]$, where E is equal to $\mathbb{P}^1/(0 \sim \infty)$ and μ_2 acts by change of sign. We now exhibit the four distinct square roots of ω_C up to isomorphism. If we denote by x a smooth point of C , we can regard this example as a check that the fibre of $M_{1,1}^{\omega/2}(2) \rightarrow M_{1,1}(2)$ over the geometric point representing (C, x) actually contains 4 distinct geometric points.

Note that ω_C is trivial, so we are actually looking for square roots of \mathcal{O}_C . Consider the normalization $C^\nu \rightarrow C$, which is isomorphic to $[\mathbb{P}^1/\mu_2]$. On C^ν there are 2 roots of \mathcal{O} : the line bundle $\mathcal{O}_{\mathbb{P}^1}$ with trivial μ_2 -action on the fibres; and the line bundle $\mathcal{O}_{\mathbb{P}^1}$ with μ_2 -action on the fibres given by $t \mapsto -t$. Each of these line bundles descend to E to form a root of \mathcal{O}_E in exactly two nonisomorphic ways. Therefore, on C , we get four square roots L^{++} , L^{+-} , L^{-+} , and L^{--} of ω_C up to isomorphism.

Note that the line bundles $L^{\sigma,\tau}$ above, are 2-torsion line bundles and can be regarded as the 2-torsion subgroups of $\text{Pic}^{\mu_2}(E)$, the group of μ_2 -linearized line bundles. Their geometric realizations are stacks fibred over C , which we describe explicitly. Let W^+ be the line bundle on E , obtained from $\mathbb{P}^1 \times \mathbb{A}^1$ by glueing the lines over 0 and ∞ via $(0, t) \sim (\infty, t)$ and let W^- be the line bundle on E obtained from $\mathbb{P}^1 \times \mathbb{A}^1$ by glueing the lines over 0 and ∞ via $(0, t) \sim (\infty, -t)$. The geometric bundles over C associated to $L^{\sigma,\tau}$ for $\sigma, \tau \in \{+, -\}$ is the quotient stack $[W^\tau/\mu_2]$ with μ_2 acting as $t \mapsto \sigma t$ on the fibres.

Since ω_C is isomorphic to \mathcal{O} , following Proposition 4.2.4, we also provide a concrete description of the line bundles above in terms of μ_2 -torsors on C . We exhibit four distinct representable 2-folded étale covers of C . Note that some points of the covering stack D over C might have nontrivial stabilizer μ_2 : in the drawings we adopt the convention of marking them with a black circle. The labelling D^{++} , D^{+-} , D^{-+} , and D^{--} matches the above notations for the line bundles.

1. *The cover D^{++} .* It is $D^{++} = \mathbb{C} \times \mu_2(k)$ on which μ_2 acts as $\text{id} \times \xi_2$. The morphism \mathfrak{p} is the projection to the first factor.



2. *The cover D^{+-} .* Take $[\mathbb{P}^1/\pm] \times \mu_2(k)$ modulo the relation $(0, \sigma) \sim (\infty, -\sigma) \quad \forall \sigma \in \mu_2$. The μ_2 -action is generated by $\text{id} \times \xi_2$ and the morphism \mathfrak{p} is the projection to the first factor.



3. *The cover D^{-+} .* Take the étale atlas $E = \mathbb{P}^1/(0 \sim \infty)$ of \mathbb{C} . The μ_2 -action is the change of sign on \mathbb{P}^1 . The morphism \mathfrak{p} is $E \rightarrow [E/\mu_2]$. Note that, the local picture of \mathfrak{p} at the node is given by $(z, w) \mapsto (z, w)$ on $\{zw = 0\} \rightarrow [\{z'w' = 0\}/\mu_2]$.

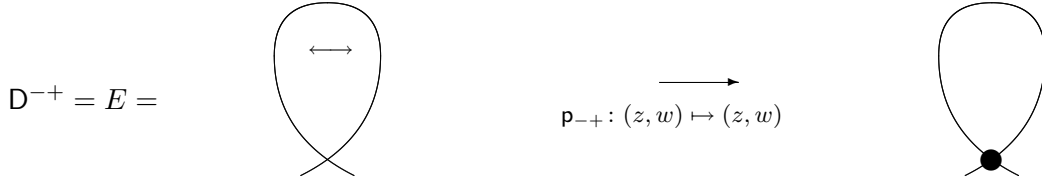

4. *The cover D^{--} .* Take $E = \mathbb{P}^1/(0 \sim \infty)$ with μ_2 acting by change of sign as above. On the smooth locus $E^{\text{sm}} \rightarrow \mathbb{C}^{\text{sm}}$ the morphism \mathfrak{p} is $x \mapsto x^2$. On the other hand, we define \mathfrak{p} so that its local picture at the node $\{zw = 0\} \rightarrow [\{z'w' = 0\}/\mu_2]$ is given by $(z, w) \mapsto (z, -w)$.

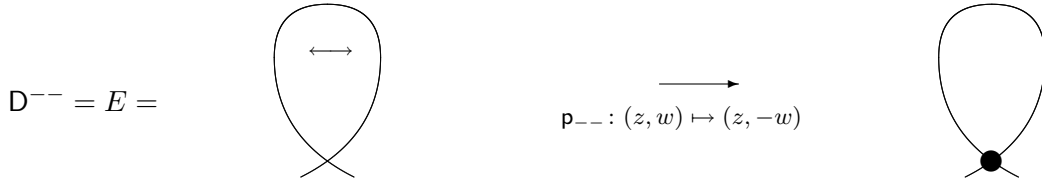

This completes the check that the fibre of $M_{1,1}^{\omega/2}(2) \rightarrow M_{1,1}(2)$ over the curve (\mathbb{C}, x) in $M_{1,1}(2)$ is the 0-dimensional stack given by 4 disjoint copies of $\mathcal{B}(\mathbb{Z}/2\mathbb{Z})$ (recall that each object has a nontrivial automorphism acting by multiplication by -1 along the fibre of the line bundle).

One can ask a natural question at this point: what is the fibre of the corresponding morphism between coarse spaces over the closed point corresponding to (\mathbb{C}, x) in the moduli space of stable curves? In order to answer this question one should note that the only automorphism of (\mathbb{C}, x) that acts nontrivially on the objects of $M_{1,1}^{\omega/2}(2)$ is the automorphism g of order 2 generating $\text{Aut}(\mathbb{C}, |\mathbb{C}|)$. Then, by Proposition 2.5.3, we note that the action of g fixes L^{++} and L^{+-} and

identifies the objects L^{-+} and L^{--} . Indeed the formula in Proposition 2.5.3 can be written as

$$\begin{aligned} \mathbf{g}^*L^{++} &= L^{++} \otimes L^{++} = L^{++}, \\ \mathbf{g}^*L^{+-} &= L^{+-} \otimes L^{++} = L^{+-}, \\ \mathbf{g}^*L^{-+} &= L^{-+} \otimes L^{+-} = L^{--}. \end{aligned}$$

Therefore, the fibre is the disjoint union of two reduced point and a third point of length two over the coarse moduli space of stable curves.

4.2.12 Remark. This analysis can be generalized to any prime integer $r > 2$. Let C be the r -stable curve on the 1-pointed nodal curve $\mathbb{P}^1/(0 \sim \infty)$. The group $\text{Aut}(C, |C|) = \mu_r$ acts freely on the $r^2 - r$ r -spin structures that are not pullbacks from $|C|$. This means that the fibre of the morphism to $\overline{M}_{1,1}$ contains 1 point representing the trivial r -spin structures and $2r - 2$ points representing nontrivial r -spin structures, half of which are pullback from the coarse space. After the identifications induced by the hyperelliptic involution we get

$$\forall r > 2 \text{ prime there are exactly } r - 1 \text{ nontrivial } r\text{-spin } r\text{-stable curves over } \mathbb{P}^1/(0 \sim \infty). \quad (4.2.13)$$

This allows to picture the coarse space of nontrivial r -spin curves of genus 1, with 1 marking. This leads us to point out the following counterexample to Conjecture 4.2.1 of [Ja01], which predicts that the Picard group of the stack of smooth r -spin 1-pointed curves of genus 1 is finite.

4.2.14 Example. The space N_r of nontrivial r -stable r -spin curves is a curve covering $|M_{1,1}|$: indeed it is an $(r^2 - 1)/2$ -fold cover of the projective line. For instance, fix $r = 11$; then $N_r \rightarrow |M_{1,1}|$ has degree 60. Over the two curves with extra automorphisms there are respectively $(r^2 - 1)/4 = 30$ and $(r^2 - 1)/6 = 20$ spin structures. By (4.2.13), there are exactly $r - 1 = 10$ singular spin curves. Then, the Euler-Poincaré characteristic is $\chi(N_r) = -60 + 40 + 20 + 10 = 0$. In this way, N_r is a genus-1 curve. The moduli stack of nontrivial r -spin structures on smooth 1-pointed genus-1 curves is a stack over the genus-1 curve N_r minus a finite number of points. Its Picard group cannot be finite. A similar computation using (4.2.13) shows that for any prime integer $r > 3$ we have

$$g(N_r) = (r - 5)(r - 7)/24. \quad (4.2.15)$$

4.3 The relation with the compactification of Abramovich and Jarvis

The compactifications [Ja00] and [AJ03] adopt two different methods but are isomorphic, [AJ03, Prop. 4.3.1]). We restate the construction. We use systematically the equivalence between line bundles on a stack X and morphisms $X \rightarrow \mathbf{B}\mathbb{G}_m$.

The compactification $\mathbf{B}_{g,n}(\mathbf{B}\mathbb{G}_m, \omega_{log}^{1/r})$ introduced in [AJ03] is the following category. An *object* is the datum of a 1-commutative diagram

$$\begin{array}{ccc} & C & \\ \swarrow L & & \searrow \omega_{C/X}(\sum_i S_i) \\ \mathbf{B}\mathbb{G}_m & \xrightarrow{k_r} & \mathbf{B}\mathbb{G}_m \end{array}$$

where k_r is induced by the homomorphism $t \mapsto t^r$ and the following conditions are satisfied.

1. The stack \mathcal{C} is of Deligne–Mumford type, flat of relative dimension 1 with nodal singularities over X .
2. The stacks $\mathcal{S}_1, \dots, \mathcal{S}_n$ are closed disjoint substacks of \mathcal{C}^{sm} and étale gerbes over X .
3. The corresponding coarse spaces $|\mathcal{C}|, |\mathcal{S}_1|, \dots, |\mathcal{S}_n|$ form a proper, n -pointed, nodal curve over X , and $\pi: \mathcal{C} \rightarrow |\mathcal{C}|$ is an isomorphism away from the nodes and the stacks \mathcal{S}_i .
4. If $\mathfrak{p}: \text{Spec } k \rightarrow \mathcal{C}$ is a node, for a suitable integer l , the local picture is given by $[V/\mu_l]$, where, for some $t \in T$, V is $\text{Spec}(T[z, w]/(zw - t))$ and μ_l acts as $(z, w) \mapsto (\xi_l z, \xi_l^{-1} w)$.
5. The morphism L is representable.

A *morphism* is a 1-commutative diagram

$$\begin{array}{ccc}
 & \mathcal{C} & \\
 & \swarrow & \searrow \\
 & \mathcal{C}' & \\
 \swarrow & & \searrow \\
 \mathcal{B}\mathbb{G}_m & \xrightarrow{k_r} & \mathcal{B}\mathbb{G}_m
 \end{array}$$

As usual, morphism are considered up to 2-isomorphisms (see Lemma 2.2.1).

In fact, we show that $\mathcal{B}_{g,n}(\mathcal{B}\mathbb{G}_m, \omega_{\log}^{1/r})$ is a compactification of

$$\bigsqcup_{0 \leq h_i < r} \mathcal{M}_{g,n}^{\omega(\mathbf{h}),r},$$

where $\omega(\mathbf{h}) := \omega(-\sum_i h_i S_i)$ is the relative dualizing sheaf on the universal curve over $\mathcal{M}_{g,n}$ twisted by the divisors S_n determining the i th marking.

4.3.1 Definition (faithful line bundles). A line bundle \mathcal{M} on a twisted curve $\mathcal{C} \rightarrow X$ is faithful if it satisfies the following condition: for each node e on \mathcal{C} the action of $\text{Aut}(e)$ on \mathcal{M}_e is faithful.

4.3.2 Remark. In the case of a line bundle \mathcal{M} whose r th tensor power is the pullback of a line bundle F on the coarse space, for any $g \in \text{Aut}(e)$ the element g^r acts as the identity on \mathcal{M}_e . Therefore, the fact that \mathcal{M} is faithful implies that $\#(\text{Aut}(e))$ divides r .

4.3.3 Proposition. *There is a finite and surjective morphism*

$$\bigsqcup_{0 \leq h_i < r} \mathcal{M}_{g,n}^{\omega(\mathbf{h}),r}(r) \longrightarrow \mathcal{B}_{g,n}(\mathcal{B}\mathbb{G}_m, \omega_{\log}^{1/r}), \tag{4.3.4}$$

where $\mathcal{M}_{g,n}^{\omega(\mathbf{h}),r}(r)$ is the stack of r th roots of $\omega(\mathbf{h}) = \omega(-\sum_i h_i S_i)$ over n -pointed r -stable curves.

The morphism (4.3.4) has degree one, but, in general, it is not an isomorphism. Indeed, consider a point $x \in \mathcal{M}_{g,n}^{\omega(\mathbf{h}),r}(r)$, its image $y \in \mathcal{B}_{g,n}(\mathcal{B}\mathbb{G}_m, \omega_{\log}^{1/r})$. We have

$$\#(\text{Aut}(x))/\#(\text{Aut}(y)) = r^m / \prod_{i=1}^m d_i$$

where d_1, \dots, d_m are the orders of the automorphism groups of the nodes $\mathbf{e}_1, \dots, \mathbf{e}_m$ of the twisted curve corresponding to \mathbf{y} .

Proof. There is an equivalence of categories

$$\mathbf{B}_{g,n}(\mathbf{B}\mathbb{G}_m, \omega_{\log}^{1/r}) \longrightarrow \bigsqcup_{0 \leq h_i < r} \mathbf{P}(h_1, \dots, h_n),$$

where $\mathbf{P}(h_1, \dots, h_n)$ is the category on $\tilde{\mathbf{M}}_{g,n}$ of faithful r th roots of $\omega(\mathbf{h}) = \omega(-\sum_i h_i S_i)$ on twisted curves. We prove the equivalence.

First, we need to introduce a decomposition of $\mathbf{B}_{g,n}(\mathbf{B}\mathbb{G}_m, \omega_{\log}^{1/r})$ into connected components $\mathbf{P}(\vec{l}, \vec{m})$. The local picture of a line bundle L on C at a point $\mathfrak{p}: \text{Spec } k \rightarrow S_i \hookrightarrow C$ is given, for suitable indexes l_i and m_i , by a μ_{l_i} -equivariant line bundle W on $[V/\mu_{l_i}]$ where V is $\text{Spec } T[z]$, the action is $z \mapsto \xi_{l_i} z$, and W is linearized by the character $\xi_{l_i} \mapsto \xi_{l_i}^{m_i}$. The coefficients l_i and m_i induce locally constant morphisms $l, m: \mathbf{B}_{g,n}(\mathbf{B}\mathbb{G}_m, \omega_{\log}^{1/r}) \rightarrow \mathbb{Z}^n$ with $0 \leq m < l$. Note also that the representability condition on L implies that l and m are coprime on each coordinate of \mathbb{Z}^n . The values taken by l and m determine a decomposition of $\mathbf{B}_{g,n}(\mathbf{B}\mathbb{G}_m, \omega_{\log}^{1/r})$ as the disjoint union of substacks $\mathbf{P}(\vec{l}, \vec{m})$ where the vectors $\vec{l} = (l_i), \vec{m} = (m_i) \in \mathbb{Z}^n$ satisfy $0 \leq \vec{l} < \vec{m}$ and $\text{hcf}\{m_i, l_i\} = 1$ for any i .

Second, there is an equivalence of category between $\mathbf{P}(\vec{l}, \vec{m})$ and the stack $\mathbf{P}(h_1, \dots, h_n)$ for $h_i = rm_i/l_i - 1$. By [Cad, Thm. 4.1] and [Ol, Thm. 1.8], there is an equivalence between the category of twisted curves equipped with n distinct sections

$$\begin{array}{ccc} & & C \\ & \nearrow & \downarrow \\ s_1 & \cdots & s_n \\ & \searrow & X \end{array}$$

in the smooth locus and the category of Deligne–Mumford stacks $C \rightarrow X$ satisfying conditions (1-4) in the definition of $\mathbf{B}_{g,n}(\mathbf{B}\mathbb{G}_m, \omega_{\log}^{1/r})$, where we require that the automorphism groups have order l_i over the points of S_i . The functor sends $(C \rightarrow X, s_1, \dots, s_n)$ to the stack $C \times_{|C|} D$, where we set $D = |C|[S_1/l_1] \times_{|C|} \cdots \times_{|C|} |C|[S_n/l_n]$ for $S_i = s_i(X)$. Note that the latter stack is equipped with a natural projection to C . For $h_i = rm_i/l_i - 1$, we have a functor $\mathbf{P}(h_1, \dots, h_n) \rightarrow \mathbf{P}(\vec{l}, \vec{m})$ induced by pushforward via the projection. Indeed, the pushforward of line bundles on D is a line bundle on $|C|$, see [AJ03, §3] or [Cad]. In this way, the functor lands in $\mathbf{P}(h_1, \dots, h_n)$ (the representability assumption at the nodes is equivalent to requiring that the r th root is faithful at the nodes). The inverse functor is induced by pullback and tensorization with the tautological line bundles $M_i^{\otimes m_i}$, which are defined on D and satisfy $M_i^{\otimes l_i} = \mathcal{O}(S_i)$.

The morphism (4.3.4) is the composite of $\mathbf{P}(h_1, \dots, h_n) \rightarrow \mathbf{P}(\vec{l}, \vec{m})$ and the disjoint union of finite and surjective morphisms of stacks

$$\mathbf{M}_{g,n}^{\omega(\mathbf{h}),r}(r) \rightarrow \mathbf{P}(h_1, \dots, h_n), \quad (4.3.5)$$

whose restriction to the open and dense substack $\mathbf{M}_{g,n}^{\omega(\mathbf{h}),r}$ is the identity and whose corresponding morphism between coarse spaces is an isomorphism. We define the morphisms (4.3.5) here below.

The functor $M_{g,n}^{\omega(\mathbf{h}),r}(r) \rightarrow \mathbb{P}(h_1, \dots, h_n)$, consists of sending morphisms of stacks $\mathbb{C} \xrightarrow{L} \mathbb{B}\mathbb{G}_m$ to the corresponding representable morphism $\mathbb{C}' \xrightarrow{L'} \mathbb{B}\mathbb{G}_m$, the “relative moduli space” making the morphism L representable [ACV03, 5.2.4,(c)]. By means of the weak valuative criterion it is easy to see that this functor defines a surjection (each geometric point is lifted as in the proof of Theorem 4.1.4). The functor sending the object determined by \mathbb{C} and L to the object determined by \mathbb{C}' and L' is not an isomorphism in general. Indeed, the ratio of the orders of the automorphism groups at the two objects is $\#(\text{Aut}(\mathbb{C}, \mathbb{C}'))$, where $\text{Aut}(\mathbb{C}, \mathbb{C}')$ denotes the group of automorphisms of \mathbb{C} that fix \mathbb{C}' (this happens because L is the pullback of L' via $\mathbb{C} \rightarrow \mathbb{C}'$). By Theorem 2.4.8, the order of $\text{Aut}(\mathbb{C}, \mathbb{C}')$ is equal to $r^m / \prod_{i=1}^m d_i$, if we denote by d_1, \dots, d_m the orders of the automorphism groups of the nodes e_1, \dots, e_m of \mathbb{C}' . \square

4.3.6 Remark (the Witten top Chern class). The Witten top Chern class is a rational Chow cohomology class which plays a crucial role in the definition of the relevant numerical invariants in Witten’s conjecture [Wi93]. Although the new compactifications are not isomorphic to the preexisting one, the surjective morphism above yields an isomorphism between the coarse spaces. This implies that the rational Chow rings are isomorphic, see for example [Kr99].

There are two equivalent formulations [PV01] and [Ch1] of the construction of the Witten top Chern class and they both use the universal stable r -spin structure of Jarvis’s compactification [Ja00], which is a sheaf of rank 1 rather than an invertible sheaf. Nevertheless they can be applied without modification to the new compactifications and yield the same class after the identification of the rational Chow cohomology rings.

4.3.7 Proposition. *The Witten top Chern class functor defined in [PV01] and [Ch1] yields a class c_W in the rational cohomology of $M_{g,n}^{\omega(\mathbf{h}),r}(r)$ as well as a class \bar{c}_W in the rational cohomology of Abramovich and Jarvis’s compactification. The outputs are compatible in the sense that c_W is a pullback of \bar{c}_W via the surjective morphism of degree one exhibited in Proposition 4.3.3.*

Proof. To see this, note that both constructions start from a datum in the derived category which is obtained by pushing Jarvis’s universal r th root \mathcal{L} and the universal homomorphism f along the universal stable curve. The morphism between our compactification and the compactification of Abramovich and Jarvis induces a morphism between the universal twisted curve on $M_{g,n}^{\omega(\mathbf{h}),r}(r)$ and the universal stable curve on Jarvis’s compactification. We only need to check that the pushforward to the universal stable curve yields the universal sheaf-theoretic stable r -spin structure (\mathcal{L}, f) of Jarvis’s construction [Ja00]. The proof of this fact can be found in [AJ03, §3, §4.3], which applies verbatim to our setting. \square

A Appendix. The stack LB_f

We analyse the category LB_f of line bundles on a flat and proper morphism $f: \mathbb{Y} \rightarrow X$, where \mathbb{Y} is a tame stack of Deligne–Mumford type, and $|f|: |\mathbb{Y}| \rightarrow X$ is flat on X . The fact that this category LB_f forms a stack even when f is not represented by a scheme is a preliminary to our compactification. We show that it can be proven by adapting Mumford’s treatment of cohomology and base change [Mu70, II, §5] to the stack-theoretic situation: $f: \mathbb{Y} \rightarrow X$. As mentioned in §3.1, M. Lieblich provides a more general statement implying this result by showing

that the category of flat families of coherent sheaves on Y with proper support over X is an algebraic stack, [Li06, Thm. 2.1.1, Lem. 2.3.1].

A.1 The fibred category \mathbf{LB}_f is a stack

Let Y be a Deligne–Mumford stack, flat and proper on a base scheme X

$$f: Y \rightarrow X.$$

We write \mathbf{LB}_f for the category of line bundles on base changes $Y_S = Y \times_X S$ for every X -scheme S . More precisely, the *objects* are pairs (S, M) , where S is an X -scheme and M is a line bundle on $Y_S = Y \times_X S$. The *morphisms* $(S, M) \rightarrow (S', M')$ are pairs (m, \mathbf{a}) , where $m \in \mathrm{Hom}_X(S, S')$ and \mathbf{a} is an isomorphism of line bundles $\mathbf{a}: M \xrightarrow{\sim} M' \times_{S'} S$ on Y_S .

A.1.1 Remark. The category \mathbf{LB}_f induces a functor sending an X -scheme S to the *groupoid* in \mathbf{LB}_f formed by the objects (S, M) on S . Even when f is a representable morphism $f: Y \rightarrow X$, such a functor differs from the functor sending an X -scheme S to the *set* $\mathrm{Pic}(Y_S)$, which is the functor used in Grothendieck’s treatment [Gr68] of the relative Picard functor. We illustrate the relation between the two functors at the end of this appendix using the notion of rigidification of a stack along a group scheme, Theorem A.2.1.

A.1.2 Proposition. *On a base scheme X , let $f: Y \rightarrow X$ be a flat and proper morphism of Deligne–Mumford type, with geometrically connected fibres, tame, and coarsely represented by an X -scheme $|Y|$, projective and flat on X . Then, the category \mathbf{LB}_f is a stack on X .*

Proof. Since the category is fibred in groupoids by definition, we only need to show

1. the representability of the isomorphism functors,
2. the effectiveness of any étale descent datum of objects

(as far as $\widetilde{\mathbf{LB}}_g$ is concerned, we ignore the issue of geometrization, namely the existence of a smooth and surjective morphism from a scheme to the stack, see Remark A.1.5). We show point (1) by means of the following statement, a stack-theoretic generalization of Mumford’s theorem on cohomology and base change [Mu70, II. §5] for schemes.

A.1.3 Lemma. *Let Y be a tame Deligne–Mumford stack, flat and proper over an affine scheme S . Assume that the morphism of schemes $|Y| \rightarrow S$ is flat. Let \mathcal{E} be a locally free and coherent sheaf on Y . Then, there exists a perfect complex $K^\bullet: 0 \rightarrow K^0 \rightarrow K^1 \rightarrow \dots \rightarrow K^n \rightarrow 0$ on S and an isomorphism of functors*

$$H^p(Y_T, \mathcal{E}_T) = H^p(K_T^\bullet)$$

on the category of S -schemes T (here, Y_T , \mathcal{E}_T , and K_T^\bullet denote the base change via $T \rightarrow S$).

Proof. Recall that the direct image via $\pi: Y \rightarrow |Y|$ is an exact functor from the category of coherent sheaves on Y to the category of coherent sheaves on $|Y|$, [AV02, Lem.2.3.4]. Therefore, we have the isomorphism $H^p(Y_T, \mathcal{E}_T) \cong H^p(|Y|_T, \pi_* \mathcal{E}_T)$, and it is enough to find a complex K^\bullet satisfying

$$H^p(|Y|_T, \pi_* \mathcal{E}_T) \cong H^p(K_T^\bullet).$$

Mumford' theorem [Mu70, II. §5] shows that such a K^\bullet exists if $\pi_*\mathcal{E}$ is a coherent sheaf, flat on $S = \text{Spec } A$. Indeed, we check that $\pi_*\mathcal{E}$ is flat on S , which means that, locally on $|\mathbf{Y}|$, there exists an affine open set on which $\pi_*\mathcal{E}$ is given by a flat A -module. This happens because, as shown in [AV02, Lem.2.2.3], for a stack \mathbf{Y} of Deligne–Mumford type, there is an étale covering $Y_\alpha \rightarrow |\mathbf{Y}|$ such that, for all α , the pullback $\mathbf{Y} \times_{|\mathbf{Y}|} Y_\alpha$ is a quotient stack of the form $[U_\alpha/G_\alpha]$, where U_α is a scheme and G_α is a finite group acting on U_α (note that since \mathbf{Y} is tame, $\#(G_\alpha)$ is prime to the residue characteristic). So, on an affine open set $V \subset |\mathbf{Y}|$, $\pi_*\mathcal{E}$ can be regarded as the direct image of a locally free G -equivariant coherent sheaf on an affine scheme $U = \text{Spec } R$. Such a sheaf can be regarded as a G -linearized R -module M . Therefore, as an \mathcal{O}_V -module, $\pi_*\mathcal{E}$ corresponds to M^G , the submodule of M of G -invariant elements. The tameness assumption implies linear reductiveness: M splits as $M^G \oplus M'$. So, as an A -module, M^G is flat, because it is a direct summand of M and, on the other hand, M is flat over R , which is flat over A . \square

Now, point (1) follows from the following lemma.

A.1.4 Lemma. *For any scheme S and objects $\alpha = (S, \mathbf{M}_\alpha)$ and $\beta = (S, \mathbf{M}_\beta)$ in LB_f the functor $\text{Isom}_S(\alpha, \beta)$ from S -schemes to sets is represented by a separated scheme locally of finite type over S .*

Proof. Write $\mathbf{D}_S = \mathbf{M}_\alpha \otimes \mathbf{M}_\beta^\vee$. We write π for $\mathbf{Y} \rightarrow |\mathbf{Y}|$, and we adopt the notation $\mathbf{p}: \mathbf{Y}_S \rightarrow S$ and $p: |\mathbf{Y}|_S \rightarrow S$. For any morphism $Z \rightarrow S$ write \mathbf{Y}_Z and \mathbf{D}_Z for the base change of \mathbf{Y}_S and \mathbf{D}_S . We need to represent the functor $\text{Isom}_S(\alpha, \beta)$ sending an S -scheme Z to the set of isomorphisms between \mathbf{M}_α and \mathbf{M}_β on Z . This is equivalent to the set of nonzero sections $s \in \Gamma(\mathbf{Y}_Z, \mathbf{D}_Z)$, where s is nowhere vanishing. By Lemma A.1.3, we can take $d: K^0 \rightarrow K^1$, a homomorphism of vector bundles on S ; then, the S -scheme $T_{\alpha, \beta} = \{d = 0\}$ of K^0 represents the functor $\text{Hom}_S(\alpha, \beta)$ sending an S -scheme Z to the set of homomorphisms between \mathbf{M}_α and \mathbf{M}_β on Z . The composition of homomorphism induces a morphism

$$c: T_{\alpha, \beta} \times_S T_{\beta, \alpha} \rightarrow T_{\alpha, \alpha}.$$

Let $1: S \rightarrow T_{\alpha, \alpha}$ be the section representing the identity homomorphism. The functor $\text{Isom}_S(\alpha, \beta)$ is represented by $\{c = 1\}$. Since K^0 is a finite dimensional vector bundle, $T_{\alpha, \beta}$ is separated and of finite type over S . It follows that the scheme representing the functor $\text{Isom}_S(\alpha, \beta)$ is separated and of finite type (it is closed in the scheme $T_{\alpha, \beta} \times_S T_{\beta, \alpha}$, which is separated and of finite type over S). \square

Finally, we show point (2): any étale descent datum of line bundles on \mathbf{Y} is effective. Indeed, given an X -scheme S , an étale cover $(S_\alpha \rightarrow S)$, and objects $(S_\alpha, \mathbf{M}_\alpha)$, where \mathbf{M}_α is a line bundle on $\mathbf{Y}_\alpha = \mathbf{Y} \times_S S_\alpha$, together with isomorphisms between pullbacks of $(S_\alpha, \mathbf{M}_\alpha)$ and $(S_\beta, \mathbf{M}_\beta)$ to $S_\alpha \times_S S_\beta$ satisfying the cocycle condition, we claim that these data descend to an object (S, \mathbf{M}) , where \mathbf{M} is a line bundle on \mathbf{Y}_S . Indeed \mathbf{M} is defined by étale descent of line bundles and morphisms of line bundles for schemes: for any scheme $T \rightarrow \mathbf{Y}_S$ the line bundle \mathbf{M}_T on T is induced by descent along the étale cover $(\mathbf{Y}_\alpha \times_{\mathbf{Y}_S} T \rightarrow T)$ of the line bundles $\mathbf{M}_\alpha \times_{\mathbf{Y}_S} T$ on $\mathbf{Y}_\alpha \times_{\mathbf{Y}_S} T$. \square

A.1.5 Remark. Although we did not show that LB_f is an algebraic stack in the sense of Artin’s definition, we point out that Lemma A.1.4 together with the fact that the relative cotangent complex of $F^{1/r} \rightarrow X$ is trivial (see 3.1.3) can be used to prove that the stack $F^{1/r}$ is algebraic. The claim follows easily from Artin’s method, in which one starts from a deformation theory, constructs formal deformation spaces, and shows that they are algebraizable. Indeed the deformation functor of $F^{1/r}$ coincides with that of X , since the relative cotangent complex of $F^{1/r} \rightarrow X$ is trivial. To finish the proof one only needs to show that formal deformations are algebraizable, which is an immediate consequence of Grothendieck’s Existence Theorem extended to tame stacks by Abramovich and Vistoli, [AV02].

A.2 Rigidification

Note that each object (S, L) of LB_f over an X -scheme S has automorphisms given by multiplication by $s \in \Gamma(S, \mathbb{G}_m)$ along the fibre of L . More precisely, $H = \mathrm{LB}_f$ and $G = \mathbb{G}_m$ fit in the following setting.

A.2.1 Theorem (Abramovich, Corti, and Vistoli, [ACV03, Thm. 5.1.5]). *Let H be a stack on a base scheme X , let G be a flat finitely presented group scheme on X , and assume that for any object τ of H over an X -scheme S there is an embedding $i_\tau: G(S) \hookrightarrow \mathrm{Aut}_S(\tau)$ compatible with pullbacks in the obvious sense (for any $\varphi: \tau \rightarrow \tau'$ in H over the morphism of X -schemes $f: S \rightarrow S'$ we have $i_\tau \circ f^* = \varphi^* \circ i_{\tau'}$). Then, there exists a stack H^G and a morphism of stacks $H \rightarrow H^G$ over X satisfying the following conditions.*

1. *For any object $\tau \in H(S)$ with image $\xi \in H^G(S)$, the set $G(S)$ lies in the kernel of $\mathrm{Aut}_S(\xi) \rightarrow \mathrm{Aut}_S(\tau)$.*
2. *The morphism $H \rightarrow H^G$ is universal for morphisms of stacks $H \rightarrow H'$ satisfying (1) above.*
3. *In the condition (1) above, if S is the spectrum of an algebraically closed field, we have $\mathrm{Aut}_S(\xi) = \mathrm{Aut}_S(\tau)/G(S)$.*

If H is an algebraic stack, then H^G is also an algebraic stack. If H is of Deligne–Mumford type, then H^G is also of Deligne–Mumford type and the coarse space $|H|$ is isomorphic to $|H^G|$.

We call H^G the *rigidification of H along G* . In [Ro, I. Prop. 3.0.2, (2)], Romagny shows that if H is a Deligne–Mumford stack, then it is “locally isomorphic” to BG (on H^G) and is indeed an étale G -gerbe.

The construction of H^G consists of two steps.

1. We define a prestack H_{pre}^G : the category whose objects are the objects of H and whose morphisms are obtained by means of a quotient operation on the sheaves of morphisms of H (for any object τ the embeddings $G(S) \hookrightarrow \mathrm{Aut}_S(\tau)$ induce a categorically injective morphism of S -group schemes of the pullback G_S of G to S to the group scheme $\mathrm{Aut}_S(\tau)$ of automorphisms of τ).
2. We pass to the stack H^G associated to the prestack H_{pre}^G in the sense of [LM00, Lem. 3.2].

This construction provides a natural framework to a standard procedure that occurs systematically in the construction of the Picard functor. In general, for any morphism of schemes $f: Y \rightarrow X$, the natural functor $S \mapsto \mathrm{Pic}(Y_S)$ from X -schemes to sets is a presheaf and is not

represented by a scheme. The actual “relative Picard functor” is defined by the passage to the associated sheaf. This point is illustrated in detail in [BLR80, Ch. 8], by Bosch, Lütkebohmert, and Raynaud. In this way, the construction of the relative Picard functor is just another way to rigidify LB_f along \mathbb{G}_m .

References

- [Ab] D. ABRAMOVICH, *Lectures on Gromov-Witten invariants of orbifolds*, Preprint: [math.AG/0512372](#).
- [ACV03] D. ABRAMOVICH, A. CORTI, A. VISTOLI, *Twisted bundles and admissible covers*, *Communications in Algebra* **31** (2003), 3547–3618.
- [AGV01] D. ABRAMOVICH, T. GRABER, A. VISTOLI, *Algebraic orbifold quantum products*. *Orbifolds in mathematics and physics* (Madison, WI, 2001), *Contemp. Math.*, 310, Amer. Math. Soc., Providence, RI, 2002. 1–24
- [AJ03] D. ABRAMOVICH, T. J. JARVIS, *Moduli of twisted spin curves*, *Proc. Amer. Math. Soc.* **131** (2003), 685–699.
- [AV02] D. ABRAMOVICH, A. VISTOLI, *Compactifying the space of stable maps*, *J. Amer. Math. Soc.* **15** (2002), 27–75.
- [AC87] E. ARBARELLO, M. CORNALBA, *The Picard groups of the moduli spaces of curves*, *Topology* **26** (1987), 153–171.
- [Ar74] M. ARTIN, *Versal deformations and algebraic stacks*, *Invent. Math.* **27** (1974), 165–189.
- [BLR80] S. BOSCH, W. LÜTKEBOHMERT, M. RAYNAUD, *Néron models*, *Results in Mathematics and Related Areas* (3), vol. **21**, Springer-Verlag, Berlin, 1990.
- [BG] J. BRYAN, T. GRABER, *The Crepant Resolution Conjecture*, Preprint: [math.AG/0610129](#).
- [Br90] L. BREEN, *Bitorseurs et cohomologie non-abélienne*, *The Grothendieck Festschrift, Vol. I*, 401–476, *Progr. Math.*, **86**, Birkhäuser Boston, Boston, MA, 1990.
- [Cad] C. CADMAN, *Using stacks to impose tangency conditions on curves*, Preprint: [math.AG/0312349](#) to appear in the *American Journal of Mathematics*.
- [CCC] L. CAPORASO, C. CASAGRANDE, M. CORNALBA, *Moduli of roots of line bundles on curves*, *Transactions of the American Mathematical Society*, to appear. [math.AG/0404078](#), 40.
- [Ch1] A. CHIODO, *The Witten top Chern class via K-theory*, *J. Algebraic Geom.*, to appear. [math.AG/0210398](#).
- [Ch2] A. CHIODO, *Roots of line bundles on curves and Néron d -models*, Preprint: <http://math1.unice.fr/~chiodo/neron.pdf>.
- [Ch3] A. CHIODO, *Towards an enumerative geometry of the moduli space of twisted curves and r -th roots*, Preprint: [math.AG/0607324](#).
- [Co87] M. CORNALBA, *Moduli of curves and theta-characteristics*, “*Lectures on Riemann Surfaces*”, Ed. M. Cornalba, X. Gomez-Mont, A. Verjovsky, World Scientific, Singapore, (1989), 560–589.
- [DM69] P. DELIGNE, D. MUMFORD, *Irreducibility of the space of curves of given genus*, *Inst. Hautes Études Sci. Publ. Math.* **36** (1969), 75–112.
- [FSZ] C. FABER, S. SHADRIN, D. ZVONKINE, *Tautological relations and the r -spin Witten conjecture*, Preprint: [math.AG/0612510](#).
- [Gr68] A. GROTHENDIECK, *Technique de descente et théorèmes d’existence en géométrie algébrique. I-V*. *Séminaire Bourbaki*, Vol. **7**, Exp. No. 236, Soc. Math. France, Paris, (1995) 221–243.

- [Ha83] J. HARER, *The second homology group of the mapping class group of an orientable surface*. Invent. Math. **72** (1983), no. 2, 221–239.
- [Il72] L. ILLUSIE, *Complexe cotangent et déformations*. I. Lecture Notes in Mathematics, Vol. 239, Springer-Verlag (1971) xv+355 pp. ; II. Lecture Notes in Mathematics, Vol. 283, Springer-Verlag (1972) vii+304 pp.
- [Ja98] T. J. JARVIS, *Torsion-free sheaves and moduli of generalized spin curves*. Compositio Mathematica, **110** (1998), 291–333.
- [Ja00] T. J. JARVIS, *Geometry of the moduli of higher spin curves*, Internat. J. Math. **11** (2000), 637–663.
- [Ja01] T. J. JARVIS, *The Picard group of the moduli of higher spin curves*, New York Journal of Mathematics, **7**, (2001), 23–47.
- [JKV01] T. J. JARVIS, T. KIMURA, A. VAINTROB,, *Moduli spaces of higher spin curves and integrable hierarchies*. Compositio Math. **126**, (2001), no. 2, 157–212.
- [JKV00] T. J. JARVIS, T. KIMURA, A. VAINTROB, *Tensor products of Frobenius manifolds and moduli spaces of higher spin curves*, Conférence Moshé Flato 1999, Vol. II (Dijon), Math. Phys. Stud., **22**, Kluwer Acad. Publ., Dordrecht, (2000), 145–166.
- [JKV05] T. J. JARVIS, T. KIMURA, A. VAINTROB, *Stable spin maps, Gromov–Witten invariants, and quantum cohomology*, Commun. Math. Phys. **259**(3), 511–543 (2005).
- [Ka89] L. KATO, *Logarithmic structures of Fontaine-Illusie*, Algebraic analysis, geometry, and number theory Johns Hopkins Univ. Press, Baltimore, MD, (1989), 191–224.
- [Ko92] M. KONTSEVICH, *Intersection theory the moduli space of curves and the matrix Airy function*. Comm. Math. Phys. **147** (1992), no. 1, 1–23.
- [Kr99] A. KRESCH, *Cycle groups for Artin stacks*, Invent. Math. **138** (1999), 495–536.
- [KM97] S. KEEL, S. MORI, *Quotients by groupoids*. Ann. of Math. (2) **145** (1997), no. 1, 193–213.
- [LM00] G. LAUMON, L. MORET-BAILLY, *Champs Algébriques*, Springer Verlag, Berlin (2000), xii+208.
- [Li06] M. LIEBLICH,, *Remarks on the stack of coherent algebras*, Int. Math. Res. Not., pages Art. ID 75273, 12, 2006.
- [Me87] N. MESTRANO, *Conjecture de Franchetta forte*. Invent. Math. **87** (1987), 365–376.
- [Mi80] J. MILNE, *Étale cohomology*. Princeton Mathematical Series, **33**. Princeton University Press, Princeton, 1980.
- [MO05] K. MATSUKI, M. OLSSON, *Kawamata-Viehweg vanishing and Kodaira vanishing for stacks* Math. Res. Letters **12** (2005), 207–217.
- [Mu70] D. MUMFORD, *Abelian varieties*, Tata Institute of Fundamental Research Studies in Mathematics, No. **5**, Bombay, 1970.
- [Ol] M. OLSSON, *On (log) twisted curves*, <http://www.ma.utexas.edu/~molsson/Logcurves.pdf>, Compositio Mathematicae, to appear.
- [PV01] A. POLISHCHUK, A. VAINTROB, *Algebraic construction of Witten’s top Chern class* in “Advances in algebraic geometry motivated by physics”, (Lowell, MA, 2000), 229–250, Contemp. Math. **276**, Ed. E. Previato, AMS, Providence, RI, (2001).
- [Ro] M. ROMAGNY, *Sur quelques aspects des champs de revêtements de courbes algébriques*, Ph.D. Thesis, 2002, 120. <http://www-fourier.ujf-grenoble.fr/THESE/ps/t120.ps.gz>
- [Wi91] E. WITTEN, *Two-dimensional gravity and intersection theory on moduli space*, Surveys in differential geometry, (Cambridge, MA, 1990), 243–310, Lehigh Univ., Bethlehem, PA, (1991).

[Wi93] E. WITTEN, *Algebraic geometry associated with matrix models of two-dimensional gravity*, “Topological methods in modern mathematics” (Stony Brook, NY, 1991) Publish or Perish, Houston, TX (1993), 235–269.

A. CHIDO: Laboratoire Painlevé, U.M.R. CNRS 8524, U.F.R. de Mathématiques, Université de Lille 1, 59655 Villeneuve d’Ascq cedex,
email: chiodo@math.univ-lille1.fr